

RESOLUTION NO. 2016 - 98

**A RESOLUTION BY THE BOARD OF COUNTY COMMISSIONERS OF ST. JOHNS COUNTY, FLORIDA, AUTHORIZING THE COUNTY ADMINISTRATOR, OR DESIGNEE, TO AWARD RFQ NO. 16-21 AND TO EXECUTE AGREEMENTS FOR CR 210 WIDENING – GREENBRIAR RD. TO CIMMARONE BLVD. – PROFESSIONAL ENGINEERING SERVICES.**

**RECITALS**

**WHEREAS**, the County desires to enter into contract with Arcadis U.S., Inc. to provide Professional Engineering Services for the widening of CR 210 from two lanes to four lanes for St. Johns County in accordance with RFQ No. 16-21; and

**WHEREAS**, the scope of the services will be to provide complete engineering design, permitting, right of way acquisition, utility coordination services, and construction documents for the four laning of CR 210; and

**WHEREAS**, through the County's formal RFQ process, Arcadis U.S., Inc. was selected as the highest ranked firm to enter into a contract with the County to perform the work referenced above; and

**WHEREAS**, the County has reviewed the terms, provisions, conditions and requirements of the proposed contract (attached hereto, an incorporated herein) and finds that entering into contracts to complete the work services serves a public purpose.

**WHEREAS**, the contract will be finalized after negotiations but will be in substantial conformance with the attached draft contract.

**NOW, THEREFORE BE IT RESOLVED BY THE BOARD OF COUNTY COMMISSIONERS OF ST. JOHNS COUNTY, FLORIDA**, as follows:

Section 1. The above Recitals are incorporated by reference into the body of this Resolution and such Recitals are adopted as finds of fact.

Section 2. The County Administrator, or designee, is hereby authorized to award RFQ 16-21 to Arcadis U.S., Inc. and to conduct negotiations to provide the services set forth therein.

Section 3. Upon successful negotiations, the County Administrator, or designee, is further authorized to execute agreements in substantially the same form and format as the attached draft on behalf of the County to provide the scope of services as specifically provided in RFQ 16-21.

Section 4. To the extent that there are typographical and/or administrative errors that do not change the tone, tenor, or concept of this Resolution, then this Resolution may be revised without subsequent approval by the Board of County Commissioners.

**PASSED AND ADOPTED** by the Board of County Commissioners of St. Johns County, Florida, this 5<sup>th</sup> day of April, 2016.

**BOARD OF COUNTY COMMISSIONERS OF ST. JOHNS COUNTY, FLORIDA**

By: [Signature]  
Chair

ATTEST: Hunter S. Conrad, Clerk

By: [Signature]  
Deputy Clerk

**RENDITION DATE** 4/7/16





**MASTER CONTINUING CONTRACT AGREEMENT**

**BID NO:** \_\_\_\_\_;  
**Master Contract #:** \_\_\_\_\_

This Contract Agreement is made as of this \_\_\_\_\_ day of \_\_\_\_\_, 2016, by and between **St. Johns County, FL**, a political subdivision of the State of Florida, with principal offices located at 500 San Sebastian View, St. Augustine, FL 32084, hereinafter referred to as "**St. Johns County**" or "**County**", and \_\_\_\_\_, authorized to do business in the State of Florida, hereinafter referred to as the "**Contractor**", with mailing address \_\_\_\_\_, Phone: ( ) - \_\_\_\_\_, Fax: ( ) - \_\_\_\_\_ and email: \_\_\_\_\_.

In consideration of the mutual promises contained herein, the COUNTY and the CONTRACTOR agree as follows:

**ARTICLE 1 – DURATION and RENEWAL**

This Contract Agreement shall become effective on \_\_\_\_\_, shall be in effect for an initial contract term of \_\_\_\_\_ ( ) calendar year, and may be renewed for up to a maximum of \_\_\_\_\_ ( ) \_\_\_\_\_ ( ) year periods, upon satisfactory performance by the Contractor, mutual agreement by both parties, and the availability of funds. While this Contract Agreement may be renewed as stated in this Article, it is expressly noted that St. Johns County is under no obligation to renew or extend this Contract Agreement. It is further expressly understood that the option of renewal is exercisable only by St. Johns County, and only upon the County’s determination that the Contractor has satisfactorily performed the Services noted in the Contract Documents.

**ARTICLE 2 - ENUMERATION OF CONTRACT DOCUMENTS**

The term "Contract Documents" shall consist of all Bid Documents and any addenda/exhibits thereto; all Specifications; this Contract Agreement, any duly executed amendments, addenda, and/or exhibits hereto; and any and all duly executed Change Orders. Any representations, whether verbal or written, that are not included in the Contract Documents do not form part of this Contract Agreement.

**ARTICLE 3 - SERVICES**

The CONTRACTOR’s responsibility under this Contract Agreement is to provide all labor, materials, and equipment necessary to perform \_\_\_\_\_ for the SJC \_\_\_\_\_ Department in accordance with Bid No: \_\_\_\_\_ and as otherwise provided in the Contract Documents.

Services provided by the Contractor shall be under the general direction of the St. Johns County \_\_\_\_\_ Department, or an authorized designee, who shall act as St. Johns County’s representative, along with the SJC Purchasing Department representative during the performance of this Contract Agreement.

**ARTICLE 4 – SCHEDULE**

The Contractor shall perform the required services as specified in the Contract Documents. The Contractor shall be required to comply with the schedule set forth in the specifications, and as coordinated with the authorized designee(s) in each respective SJC Department, throughout the duration of the contract. No changes to said schedule shall be made without prior written authorization from one of St. Johns County’s representatives.

**ARTICLE 5 – COMPENSATION/BILLING/INVOICES**

- A. St. Johns County shall compensate the Contractor based upon \_\_\_\_\_, as submitted in the proposal, accepted by the County, and provided herein on Exhibit A-1. The maximum amount available as compensation to the Contractor under this Contract Agreement shall not exceed the annual amount budgeted by the St. Johns County \_\_\_\_\_ Department, unless additional funds become available, or are properly transferred, for services satisfactorily performed in accordance with the Contract Documents.
- B. It is strictly understood that Contractor is not entitled to the above-referenced amount of compensation. Rather, the Contractor’s compensation shall be based upon the Contractor’s adhering to the Scope of Services, detailed in the Contract Documents. As such, the Contractor’s compensation is dependent upon satisfactory completion of services stated in the Specifications, and included by reference in this Contract Agreement.
- C. The Contractor shall bill the County at the end of each month, for Services satisfactorily performed. The County

reserves the right to pro-rate or refuse payment of any submitted invoice where services were not satisfactorily performed.

- D. Though there is no billing form or format pre-approved by either the County, or the Contractor, bills/invoices submitted by the Contractor shall include a detailed written report of the Work accomplished in connection with the Scope of Services, and as specified in the Bid. The County may return a bill/invoice from the Contractor, and request additional documentation/information when necessary to validate payment. Under such circumstances, the timeframe for payment will be extended by the time necessary to receive a verified bill/invoice.
- E. Unless otherwise notified, bills/invoices should be delivered to:
  
- F. **FINAL INVOICE:** In order for the County and the Contractor to reconcile/close their books and records, the Contractor shall clearly indicate "final invoice" on the final bill/invoice submitted to the County for payment. Such indication establishes that all Services have been satisfactorily performed and that all charges and costs have been invoiced to the County and that there is no further Work to be performed under this Contract Agreement.

**ARTICLE 6 – TRUTH-IN-NEGOTIATION CERTIFICATE**

The signing of this Contract by the Contractor shall act as the execution of a truth-in-negotiation certificate certifying that the wage rates and cost used to determine the compensation provided for in this Contract are accurate, complete and current as of the date of the Contract.

The said rates and costs shall be reduced to exclude any significant sums should the County determine that the rates and costs were increased due to inaccurate, incomplete or non-current wage rate, or due to inaccurate representations of fees paid to outside subcontractors. The County may exercise its rights under this Article 4 within eighteen (18) months following final payment.

**ARTICLE 7 – TERMINATION**

- A. This Contract may be terminated by the County without cause upon at least \_\_\_\_\_ ( ) calendar days advance written notice to the Contractor of such termination without cause.
- B. This Contract may be terminated by the County with cause upon at least \_\_\_\_\_ ( ) calendar days advanced written notice of such termination with cause. Such written notice shall indicate the exact cause for termination.

**ARTICLE 8 – NOTICE OF DEFAULT/RIGHT TO CURE**

- A. Should the Contractor fail to perform (default) under the terms of this Contract, then the County shall provide written notice to the Contractor, which such notice shall include a timeframe of no fewer than \_\_\_\_\_ ( ) consecutive calendar days in which to cure the default. Failure by the Contractor to cure the default, or take acceptable corrective action within the timeframe provided in the notice of default (or any such amount of time as mutually agreed to by the parties in writing), shall constitute cause for termination of this Contract.
- B. It is expressly noted that, should the County issue more than one notice of default to the Contractor during the term of this Contract, such action shall constitute cause for termination of this Contract.
- C. Consistent with other provisions in this Contract, Contractor shall be paid for services authorized and satisfactorily performed under this Contract up to the effective date of termination.
- D. Upon receipt of a notice of termination, except as otherwise directed by the County in writing, the Contractor shall:
  - 1. Stop work on the date to the extent specified.
  - 2. Terminate and settle all orders and subcontracts relating to the performance of the terminated work.
  - 3. Transfer all work in process, completed work, and other material related to the terminated work to the County.
  - 4. Continue and complete all parts of the work that have not been terminated.

**ARTICLE 9 – PERSONNEL**

The Contractor represents that it has, or shall secure at its own expense, all necessary personnel required to perform the Services as noted in the Contract Documents. It is expressly understood that such personnel shall not be employees of, or

have any contractual relationship with the County.

All of the Services required hereunder shall be performed by the Contractor, or under its supervision. All personnel engaged in performing the Services shall be fully qualified and, if required, authorized or permitted under federal, state and local law to perform such Services.

Any changes or substitutions in the Contractor's key personnel must be made known to the County's representative and written approval granted by the County before said change or substitution can become effective.

The Contractor warrants that all Services shall be performed by skilled and competent personnel to the highest professional standards in the field.

#### **ARTICLE 10 – SUBCONTRACTING**

St. Johns County reserves the right to approve the use of any subcontractor, or to reject the selection of a particular subcontractor, and to inspect all facilities of any subcontractors in order to make a determination as to the capability of the subcontractor to perform the Work described in the Contract Documents. The Contractor is encouraged to seek minority and women business enterprises for participation in subcontracting opportunities.

If a subcontractor fails to satisfactorily perform in accordance with the Contract Documents, and it is necessary to replace the subcontractor to complete the Work in a timely fashion, the Contractor shall promptly do so, subject to approval by the County.

The County reserves the right to disqualify any subcontractor, vendor, or material supplier based upon prior unsatisfactory performance.

#### **ARTICLE 11 – FEDERAL AND STATE TAX**

In accordance with Local, State, and Federal law, the County is exempt from the payment of Sales and Use Taxes. The County shall execute a tax exemption certificate submitted by the Contractor. The Contractor shall not be exempt from the payment of all applicable taxes in its performance under this Contract Agreement. It is expressly understood by the County and by the Contractor that the Contractor shall not be authorized to use the County's Tax Exemption status in any manner.

The Contractor shall be solely responsible for the payment and accounting of any and all applicable taxes and/or withholdings including but not limited to Social Security payroll taxes (FICA), associated with or stemming from Contractor's performance under this Contract Agreement.

#### **ARTICLE 12 – AVAILABILITY OF FUNDS**

St. Johns County's obligations under this Contract Agreement are subject to the availability of lawfully appropriated funds. While the County will make all reasonable efforts, in order to provide funds needed to perform under this Contract Agreement, the County makes no express commitment to provide such funds in any given County Fiscal Year. Moreover, it is expressly noted that the Contractor cannot demand that the County provide any such funds in any given County Fiscal Year.

#### **ARTICLE 13 - INSURANCE**

The Contractor shall not commence work under this Contract until he/she has obtained all insurance required under this section and such insurance has been approved by St. Johns County. All insurance policies shall be issued by companies authorized to do business under the laws of the State of Florida. The Contractor shall furnish proof of Insurance to the County prior to the commencement of operations. The Certificate(s) shall clearly indicate the Contractor has obtained insurance of the type, amount, and classification as required by contract and that no material change or cancellation of the insurance shall be effective without thirty (30) days prior written notice to the County. Certificates shall specifically include the County as Additional Insured for all lines of coverage except Workers' Compensation and Professional Liability. A copy of the endorsement must accompany the certificate. Compliance with the foregoing requirements shall not relieve the Contractor of its liability and obligations under this Contract.

Certificate Holder Address: St. Johns County, a political subdivision of the State of Florida  
500 San Sebastian View  
St. Augustine, Fl 32084

The Contractor shall maintain during the life of this Contract, Comprehensive General Liability Insurance with minimum

limits of \$1,000,000 per occurrence, \$2,000,000 aggregate, to protect the Contractor from claims for damages for bodily injury, including wrongful death, as well as from claims of property damages which may arise from any operations under this contract, whether such operations be by the Contractor or by anyone directly employed by or contracting with the Contractor.

The Contractor shall maintain during the life of this Contract, Comprehensive Automobile Liability Insurance with minimum limits of \$300,000 combined single limit for bodily injury and property damage liability to protect the Contractor from claims for damages for bodily injury, including the ownership, use, or maintenance of owned and non-owned automobiles, including rented/hired automobiles whether such operations be by the Contractor or by anyone directly or indirectly employed by the Contractor.

The Contractor shall maintain during the life of this Contract, adequate Workers' Compensation Insurance in at least such amounts as is required by the law for all of its employees per Florida Statute 440.02.

In the event of unusual circumstances, the County Administrator or his designee may adjust these insurance requirements.

#### **ARTICLE 14 - INDEMNIFICATION**

The Contractor shall indemnify and hold harmless the County, its officers, and employees, from all liabilities, damages, losses, and costs arising under this Contract Agreement, including, but not limited to, reasonable attorneys' fees, to the extent caused by the negligence, recklessness, act, or omission of the Contractor or any other person employed or utilized by the Contractor, whether intentional or unintentional.

#### **ARTICLE 15 - SUCCESSORS AND ASSIGNS**

The County and the Contractor each binds itself and its partners, successors, executors, administrators and assigns to the other party of this Contract Agreement and to the partners, successors, executors, administrators and assigns of such other party, in respect to all covenants of this Contract Agreement. Except as above, neither the County nor the Contractor shall assign, sublet, convey or transfer its interest in this Contract Agreement without the written consent of the other. Nothing herein shall be construed as creating any personal liability on the part of any officer or agent of the County, which may be a party hereto, nor shall it be construed as giving any rights or benefits hereunder to anyone other than the County and the Contractor.

#### **ARTICLE 16 - REMEDIES**

No remedy herein conferred upon any party is intended to be exclusive, or any other remedy, and each and every such remedy shall be cumulative and shall be in addition to every other remedy given hereunder or nor or hereafter existing at law or in equity or by statute or otherwise. No single or partial exercise by any party or any right, power, or remedy hereunder shall preclude any other or further exercise thereof.

In any action brought by either party for the enforcement of the obligations of the other party, the prevailing party shall be entitled to recover reasonable attorney's fees.

#### **ARTICLE 17 - CONFLICT OF INTEREST**

The Contractor represents that it presently has no interest and shall acquire no interest, either directly or indirectly, which would conflict in any manner with the performance of services required hereunder. The Contractor further represents that no person having any interest shall be employed for said performance.

The Contractor shall promptly notify St. Johns County, in writing, by certified mail of all potential conflicts of interest for any prospective business association, interest or other circumstance, which may influence or appear to influence the Contractor's judgment or quality of services being provided hereunder. Such written notification shall identify the prospective business association, interest or circumstance, the nature of work that the Contractor may undertake and request an opinion of the County, whether such association, interest, or circumstance constitutes a conflict of interest if entered into by the Contractor.

The County agrees to notify the Contractor of its opinion by certified mail within 30 days of receipt of notification by the Contractor. If, in the opinion of the County, the prospective business association, interest or circumstance would not constitute a conflict of interest by the Contractor, the County shall so state in the notification and the Contractor shall, at his/her option enter into said association, interest or circumstance and it shall be deemed not in conflict of interest with respect to services provided to the County by the Contractor under the terms of this Contract Agreement.

#### **ARTICLE 18 - EXCUSABLE DELAYS**

The Contractor shall not be considered in default by reason of any delay in performance if such delay arises out of causes reasonably beyond the Contractor's control and without its fault or negligence. Such cases may include, but are not limited to: acts of God; the County's ommissive and commissive failures; natural or public health emergencies; freight embargoes; and severe weather conditions.

If delay is caused by the failure of the Contractor's subcontractor(s) to perform or make progress, and if such delay arises out of causes reasonably beyond the control of the Contractor and its subcontractor(s) and is without the fault or negligence of either of them, the Contractor shall not be deemed to be in default.

Upon the Contractor's request, St. Johns County shall consider the facts and extent of any delay in performing the work and, if the Contractor's failure to perform was without its fault or negligence, the Contract Schedule and/or any other affected provision of this Contract Agreement shall be revised accordingly; subject to the County's right to change, terminate, or stop any or all of the Work at any time.

#### **ARTICLE 19 - ARREARS**

The Contractor shall not pledge the County's credit, or make it a guarantor of payment, or surety for any contract, debt, obligation, judgment, lien, or any form of indebtedness. The Contractor further warrants and represents that it has no obligation or indebtedness that would impair its ability to fulfill the terms of this Contract Agreement.

#### **ARTICLE 20 - DISCLOSURE AND OWNERSHIP OF DOCUMENTS**

The Contractor shall deliver to the County for approval and acceptance, and before being eligible for final payment of any amounts due, all documents and materials prepared by and for the County under this Contract Agreement.

All written and oral information not in the public domain, or not previously known, and all information and data obtained, developed, or supplied by St. Johns County, or at its expense, shall be kept confidential by the Contractor and shall not be disclosed to any other party, directly or indirectly, without the County's prior written consent, unless required by a lawful order. All drawings, maps, sketches, and other data developed, or purchased under this Contract Agreement, or at the County's expense, shall be and remains the County's property and may be reproduced and reused at the discretion of the County.

The County and the Contractor shall comply with the provisions of Chapter 119, Florida Statutes (Public Records Law).

All covenants, agreements, representations and warranties made herein, or otherwise made in writing by any party pursuant hereto, including but not limited to, any representations made herein relating to disclosure or ownership of documents, shall survive the execution and delivery of this Contract Agreement and the consummation of the transactions contemplated hereby.

#### **ARTICLE 21 - INDEPENDENT CONTRACTOR RELATIONSHIP**

The Contractor is, and shall be, in the performance of all work services and activities under this Contract Agreement, an independent contractor, and not an employee, agent, or servant of St. Johns County. All persons engaged in any of the work or services performed pursuant to this Contract Agreement shall at all times and in all places be subject to the Contractor's sole direction, supervision, and control.

The Contractor shall exercise control over the means and manner in which it and its employees perform the work, and in all respects the Contractor's relationship and the relationship of its employees to St. Johns County shall be that of an independent contractor and not as employees or agents of the County. The Contractor does not have the power or authority to bind the County in any promise, agreement or representation other than specifically provided for in this agreement.

#### **ARTICLE 22 - CONTINGENT FEES**

The Contractor warrants that it has not employed or retained any company or person, other than a bona fide employee working solely for the Contractor to solicit or secure this Contract Agreement and that it has not paid or agreed to pay any person, company, corporation, individual, or firm, other than a bona fide employee working solely for the Contractor, any fee, commission, percentage, gift, or any other consideration contingent upon or resulting from the award or making of this Contract Agreement.

**ARTICLE 23 - ACCESS AND AUDITS**

The Contractor shall maintain adequate records to justify all charges, expenses, and costs incurred in performing the work for at least three (3) years after completion of this Contract Agreement. St. Johns County shall have access to such books, records, and documents as required in this section for the purpose of inspection or audit during normal business hours, at the County's cost, upon five (5) days written notice.

**ARTICLE 24 - NONDISCRIMINATION**

The Contractor warrants and represents that all of its employees are treated equally during employment without regard to race, color, religion, physical handicap, sex, age or national origin.

**ARTICLE 25 - ENTIRETY OF CONTRACTUAL AGREEMENT**

The County and the Contractor agree that this Contract Agreement, signed by both parties sets forth the entire agreement between the parties, and that there are no promises or understandings other than those stated herein, or are incorporated by reference into this Contract Agreement. None of the provisions, terms, conditions, requirements, or responsibilities noted in this Contract Agreement may be amended, revised, deleted, altered, or otherwise changed, modified, or superseded, except by written instrument, duly executed by authorized representatives of both the County, and the Contractor.

**ARTICLE 26 - ENFORCEMENT COSTS**

If any legal action or other proceeding is brought for the enforcement of this Contract Agreement, or because of an alleged dispute, breach, default or misrepresentation in connection with any provisions of this Contract Agreement, the successful or prevailing party or parties shall be entitled to recover reasonable attorney's fees, court costs and all reasonable expenses even if not taxable as court costs (including, without limitation, all such reasonable fees, costs and expenses incident to appeals), incurred in that action or proceedings, in addition to any other relief to which such party or parties may be entitled.

**ARTICLE 27 - AUTHORITY TO PRACTICE**

The CONTRACTOR hereby represents and warrants that it has and shall continue to maintain all license and approvals required to conduct its business, and that it shall at all times, conduct its business activities in a reputable manner.

**ARTICLE 28 - SEVERABILITY**

If any term or provision of this Contract Agreement, or the application thereof to any person or circumstances shall, to any extent, be held invalid or unenforceable, the remainder of this Contract Agreement, or the application of such items or provision, to persons or circumstances other than those as to which it is held invalid or unenforceable, shall not be affected and every other term and provision of this Contract Agreement shall be deemed valid and enforceable to the extent permitted by law.

**ARTICLE 29 - AMENDMENTS AND MODIFICATIONS**

No amendments or modifications of this Contract Agreement shall be valid unless in writing and signed by each of the parties.

St. Johns County reserves the right to make changes in the work, including alterations, reductions therein or additions thereto. Upon Contractor's receipt of notification from the County of a contemplated change, the Contractor shall: (1) if requested by the County, provide an estimate for the increase or decrease in cost due to the contemplated change; (2) notify the County of any estimated change in the completion date; and (3) advise the County in writing if the contemplated change shall effect the Contractor's ability to meet the completion dates or schedules of this Contract Agreement. If the County instructs in writing, the Contractor shall suspend work on that portion of the project, pending the County's decision to proceed with the change. If the County elects to make the change, the County shall issue a Change Order for changes, or a contract change order, if the original contract is to be changed or amended the Contractor shall not commence work on any such change until such written change order has been issued and signed by each of the parties.

**ARTICLE 30 - FLORIDA LAW & VENUE**

This Contract Agreement shall be governed by the laws of the State of Florida. Any and all legal action necessary to enforce the Contract shall be held in St. Johns County, Florida.

**ARTICLE 31 - ARBITRATION**

The Owner shall not be obligated to arbitrate or permit any arbitration binding on the Owner under any of the Contract

Documents or in connection with the project in any manner whatsoever.

### **ARTICLE 32 - NOTICES**

All notices required in this Contract Agreement shall be sent by certified mail, return receipt requested, and if sent to the County shall be mailed to:

St. Johns County Purchasing Department  
**Attn: Jaime Locklear, CPPB, Contract Administration Manager**  
500 San Sebastian View  
St. Augustine, FL 32084

and if sent to the Contractor shall be mailed to:

### **ARTICLE 33 - HEADINGS**

The heading preceding the articles and sections herein are solely for convenience of reference and shall not constitute a part of this Contract Agreement, or affect its meaning, construction or effect.

### **ARTICLE 34 – PUBLIC RECORDS**

- A. The cost of reproduction, access to, disclosure, non-disclosure, or exemption of records, data, documents, and/or materials, associated with this Agreement shall be subject to the applicable provisions of the Florida Public Records Law (Chapter 119, Florida Statutes), and other applicable State and Federal provisions. Access to such public records, may not be blocked, thwarted, and/or hindered by placing the public records in the possession of a third party, or an unaffiliated party.
- B. In accordance with Florida law, to the extent that Contractor's performance under this Agreement constitutes an act on behalf of the County, Contractor shall provide access to all public records made or received by Contractor in conjunction with this Agreement. Specifically, if Contractor is expressly authorized, and acts on behalf of the County under this Agreement, Contractor shall:
  - (1) Keep and maintain public records that ordinarily and necessarily would be required by the County in order to perform the services described herein;
  - (2) Provide the public with access to public records related to this Agreement on the same terms and conditions that the County would provide the records, and at a cost that does not exceed the costs provided in Chapter 119, Florida States, or as otherwise provided by applicable law;
  - (3) Ensure that public records related to this Agreement that are exempt or confidential and exempt from public disclosure are not disclosed except as authorized by applicable law; and
  - (4) Meet all requirements for retaining public records, and transfer at Contractor's sole cost and expense, all public records in the possession of Contractor upon termination of this Agreement. Contractor shall destroy any duplicate records that are exempt or confidential and exempt from public disclosure requirements in accordance with applicable State and Federal provisions. Any public records stored electronically must be provided to the County in a format that is compatible with information technology systems maintained by the County.
- C. Failure by Contractor to grant such public access shall be grounds for immediate, unilateral termination of this Agreement by the County. Contractor shall promptly provide the County notice of any request to inspect or copy public records related to this Agreement in Contractor's possession and shall promptly provide the County a copy of Contractor's response to each such request.

### **ARTICLE 35 – NO THIRD PARTY BENEFICIARIES**

Both the County and the Contractor explicitly agree, and this Contract explicitly states that no third party beneficiary status or interest is conferred to, or inferred to, any other person or entity.

**ARTICLE 36 – USE OF COUNTY LOGO**

Pursuant to, and consistent with, County Ordinance 92-2 and County Administrative Policy 101.3, the Contractor may not manufacture, use, display, or otherwise use any facsimile or reproduction of the County Seal/Logo without express written approval of the Board of County Commissioners of St. Johns County, Florida.

**ARTICLE 37 – SURVIVAL**

It is explicitly noted that the following provisions of this Contract Agreement, to the extent necessary, shall survive any suspension, termination, cancellation, revocation, and/or non-renewal of this Contract Agreement, and therefore shall be both applicable and enforceable beyond any suspension, termination, cancellation, revocation, and/or non-renewal: (1) Truth-in-Negotiation; (2) Federal and State Taxes; (3) Insurance; (4) Indemnification; (5) Access and Audits; (6) Enforcement Costs; and (7) Access to Records.

-----

IN WITNESS WHEREOF, authorized representatives of the County, and Contractor have executed three (3) original copies this Contract Agreement on the date and year below noted.

**ST. JOHNS COUNTY, FL:**

**CONTRACTOR:**

\_\_\_\_\_  
Dawn Cardenas, Purchasing Manager

\_\_\_\_\_  
Company Name

\_\_\_\_\_  
Date

\_\_\_\_\_  
Name (Type or Print)

**LEGALLY SUFFICIENT:**

\_\_\_\_\_  
Signature

\_\_\_\_\_  
Assistant County Attorney

\_\_\_\_\_  
Title

\_\_\_\_\_  
Date of Execution

\_\_\_\_\_  
Date

**ATTEST:  
CLERK OF COURT**

\_\_\_\_\_  
Deputy Clerk

\_\_\_\_\_  
Date

**EXHIBIT "A"**

**BID NO:** \_\_\_\_\_ ; \_\_\_\_\_

**BASIS OF COMPENSATION**

Basis of compensation shall be made in accordance with \_\_\_\_\_ as submitted on the proposal and approved by the County. The Price shall include all direct costs, indirect costs, and reimbursable expenses necessary to complete the scope of work. Requests for additional services or additional line items shall be submitted in writing and approved by St. Johns County ***prior*** to any work being implemented and shall be added to the applicable Contract Amendment.

Pricing adjustments will be considered on an annual basis at the time of contract renewal and must be mutually accepted by both the Contractor and the Owner. Price adjustment requests shall be based upon the Consumer Price Index (CPI) in affect at the time of renewal. All accepted and approved price adjustments shall become effective on the first day of the applicable renewal period.

EXHIBIT "A-1"

BID NO: \_\_\_\_\_ ;

---

PRICING

**EXHIBIT "B"**

**BID NO:** \_\_\_\_\_ ;

**CONTRACT SCHEDULE**

The Contract Period for this scope of work shall be as follows:

**Initial Contract** – Shall become effective on \_\_\_\_\_, and shall remain in effect for a period of \_\_\_\_\_ ( ) year, or until funds may become exhausted.

**Contract Renewal/s** – The contract may be renewed for \_\_\_\_\_ ( ), \_\_\_\_\_ ( ) year terms upon satisfactory performance by the Contractor, mutual agreement by all parties, the availability of funds and the continued need of the County for services.



## St. Johns County Board of County Commissioners

Purchasing Division

### NOTICE OF INTENT TO AWARD

March 14, 2016

RE: RFQ 16-21 CR 210 Widening – Professional Engineering Services

Please be advised that the Purchasing Department of St. Johns County is issuing this notice of its Intent to Award a contract, after successful negotiations, to Arcadis U.S., Inc. as the top ranked rank firm under RFQ 16-21 CR 210 Widening – Professional Engineering Services. This notice will remain posted St. Johns County Purchasing Department bulletin board until 10:00AM, Thursday, March 17, 2016.

Any person (including any bidder or proposer) who is, or claims to be, adversely affected by the County's decision or proposed decision shall file a written Notice of Protest with the Purchasing Department of St. Johns County within 72 hours after the posting of the notice of decision or proposed decision. Failure to file a Notice of Protest within the time prescribed in Section 304.10 of the St. Johns County Purchasing Manual (the Bid Protest Procedure), or failure to post the bond or other security required by the County within the time allowed for filing a bond, shall constitute a waiver of proceedings and a waiver of the right to protest. The protest procedures may be obtained from the Purchasing Department and are included in the County's Purchasing Manual. All of the terms and conditions of the County Purchasing Manual are incorporated herein by reference and are fully binding.

Should the Purchasing Department receive no protests in response to this notice, an agenda item will be submitted to the St. Johns County Board of County Commissioners for their consideration and subsequent approval to award a contract.

Please forward all correspondence, requests or inquiries directly to my attention, Karen R. Fullerton, Procurement Supervisor, in the Purchasing Department at [kfullerton@sjcfl.us](mailto:kfullerton@sjcfl.us).

If you have any questions regarding this Notice of Intent to Award please contact Dawn Cardenas, Purchasing Manager, St. Johns County Purchasing Department at (904) 209-0152.

Sincerely,

**St. Johns County**  
**Board of County Commissioners**

Karen R. Fullerton  
County Representative Signature

Date: 3/14/16

Karen R. Fullerton, Procurement Supervisor  
Name & Title (Printed)



**ST. JOHNS COUNTY  
PURCHASING DEPARTMENT**

500 San Sebastian View  
St. Augustine, Florida 32084

---

**I N T E R O F F I C E   M E M O R A N D U M**

---

**TO:** Press Tompkins, Engineering  
**FROM:** Dawn Cardenas, Purchasing Manager  
**SUBJECT:** RFQ 16-21 CR 210 Widening – Professional Engineering Services  
**DATE:** February 25, 2016

Attached please find a copy of the RFQ Evaluation Summary Sheet for your file as recorded and verified at the Evaluation Committee Meeting.

Please review, evaluate and make a written recommendation for this project. Also, indicate the budgeted amount for this item along with the appropriate charge code and return to my attention as soon as possible.

Please let me know if I can assist your department in any other way.

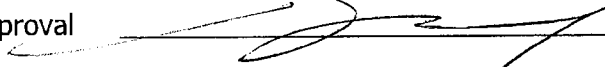
Dept. Approval   
Date 3-9-14  
Budget Amount 2180039.00  
Account Funding Title TRANSPORTATION TRUST FUND  
Funding Charge Code 1114-56330-5072  
Award to ARCADIS U.S. INC.  
Award Amount TPD

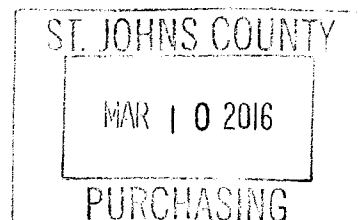

# EVALUATION SUMMARY SHEET

Date: February 25, 2016  
RFP: RFQ 16-21 CR 210 Widening

ST. JOHNS COUNTY, FLORIDA

FIRM	RATER Brian Kelsay	RATER Hank Meiri	RATER Nick Perpich	RATER Phong Nguyen	RATER Scott Trigg	TOTAL	RANK	COMMENTS
Alliant Engineering, Inc.	79	67	55	81.00	78	360	12	
Arcadis U.S., Inc.	87	76	87	90.25	91	431	1	
Ayres Associates, Inc.	80	73	90	85.50	90	419	2	
CH2M	83	75	72	83.00	83	396	7	
Connelly & Wicker, Inc.	86	73	60	90.25	80	389	10	
DRMP, Inc.	78	75	76	90.25	84	403	5	
GAI Consultants	82	76	74	90.75	90	413	4	
H.W. Lochner, Inc.	70	73	77	90.25	86	396	6	
Infrastructure Engineers, Inc.	75	73	49	87.50	85	370	11	
Johnson, Mirmiran & Thompson, Inc.	70	70	43	86.50	84	354	13	
Matthews Design Group, Inc.	74	76	74	86.75	82	393	9	
Prosser, Inc.	82	75	66	87.00	84	394	8	
RS&H, Inc.	80	72	89	90.25	85	416	3	

APPROVED: Purchasing Manager  
County Engineer, Press Tompkins

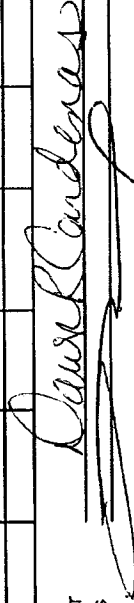

**NOTE:**  
THE RANKING SHOWN ABOVE MUST BE FOLLOWED UNLESS SPECIAL CONDITIONS MERIT A CHANGE IN THE NEGOTIATING ORDER; IN THIS CASE, THE SPECIAL CONDITIONS MUST BE EXPLAINED IN DETAIL IN THE COMMENTS SECTION OR ATTACHED TO THIS RANKING SHEET.

POSTING TIME/DATE FROM 1:00 p.m. February 25, 2016, UNTIL 1:00 p.m. February 28, 2016.

ANY RESPONDENT AFFECTED ADVERSELY BY AN INTENDED DECISION WITH RESPECT TO THE AWARD OF ANY REQUEST FOR PROPOSAL SHALL FILE WITH THE PURCHASING DEPARTMENT FOR ST. JOHNS A WRITTEN NOTICE OF INTENT TO FILE A PROTEST NOT LATER THAN SEVENTY-TWO (72) HOURS (EXCLUDING SATURDAY, SUNDAY AND LEGAL HOLIDAYS) AFTER THE POSTING OF THE SUMMARY SHEET. PROTEST PROCEDURES MAY BE OBTAINED IN THE PURCHASING DEPARTMENT.

# RFQ QUALIFICATION COVER PAGE



**PART VII: – ATTACHMENTS/FORMS**

**REQUEST FOR QUALIFICATIONS (RFQ) NO: 16-21  
CR 210 Widening - Greenbriar Rd. to Cimarrone Blvd.  
Professional Engineering Services**

**COVER PAGE**

**SUBMIT ONE (1) ORIGINAL AND FIVE (5) COPIES TO:**

PURCHASING DEPARTMENT  
ST. JOHNS COUNTY  
500 SAN SEBASTIAN VIEW  
ST. AUGUSTINE FLORIDA 32084  
ATTN: Karen Fullerton, Procurement Supervisor

**COMPANY NAME:** Arcadis U.S., Inc.

**DATE:** February 4, 2016

Ms. Karen Fullerton  
Procurement Supervisor  
SJC Purchasing Department  
500 San Sebastian View  
St. Augustine, FL 32084

Arcadis U.S., Inc.  
1650 Prudential Drive  
DuPont Center  
Suite 400  
Jacksonville  
Florida 32207  
Tel 904 721 2991  
Fax 904 861 24530  
[www.arcadis.com](http://www.arcadis.com)

Subject: RFQ No: 16-21  
County Road (CR) 210 Widening from Greenbriar Rd to Cimarrone Blvd.  
Professional Engineering Services

Infrastructure

Dear Ms. Fullerton:

As one of your consultants for the past 40 years, Arcadis understands the issues you face every day to meet the needs of a growing county. Our experienced design teams have provided you innovative and cost effective solutions on multiple roadway improvements, signal designs, and drainage designs.

Date:  
February 4, 2016

**Contact**

Walter Nemecek, PE – Project Manager  
1650 Prudential Drive, Suite 400 | Jacksonville, FL 32207  
Phone: 904.861.2844 | Fax: 904.861.2450  
[Walter.nemecek@arcadis.com](mailto:Walter.nemecek@arcadis.com)

**Project Understanding**

We understand this opportunity is to widen CR 210 for 2.27 miles. The new typical section includes four lanes with curb and gutter and pedestrian access meeting all Florida Department of Transportation (FDOT) standards. Our engineering services include design, permitting, public involvement, utility coordination, and construction documents. All work is delivered with innovation, cost efficiency, and ease of construction at the forefront of all decisions.

**Arcadis Profile**

Arcadis, established in 1888, is the leading global design & consultancy firm for natural and built assets. Applying our deep market sector insights and collective design, consultancy, engineering, and project management services, we work in partnership with our clients to deliver exceptional and sustainable outcomes throughout the lifecycle of their natural and built assets. We are 28,000 people active in over 70 countries that generate more than \$3.5 billion in revenues. The local Jacksonville office employs 55 professionals prepared to serve you.

We are excited about working with you on this opportunity and would like to provide professional engineering services for this CR 210 Widening. We commit to you an exceptional project manager, Walter Nemecek, and technical leaders you have come to depend on over the years for quality services at competitive costs and in a timely manner. We look forward to the opportunity to work with you and exceed your expectations.

Sincerely,  
Arcadis U.S., Inc.

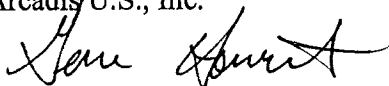

Gene Howerton, PE  
Principal-in-Charge

# COMPANY & STAFF QUALIFICATIONS



### 3. COMPANY AND STAFF QUALIFICATIONS

Arcadis' commitment to St. Johns County runs deep. For more than 40 years, we have been a trusted partner to you. We are currently working together on the Continuing Contract for Engineering Services, a contract we have held for over 15 years. We successfully completed over a dozen task work orders for you under this contract and are currently working on SR 16 and International Golf Parkway Intersection Improvements. We understand the needs and issues facing you today and will work hand-in-hand to navigate them.

We have been serving clients in Northeast Florida with unmatched service and innovative and cost-saving designs for more than 48 years. We offer a wide range of transportation, planning, and engineering services all in-house. We have the right combination of roadway widening experience and ability to successfully complete the CR 210 project.

Our Jacksonville, Florida, office is responsible for completing this project. We are located just 25 minutes from the project site. This office consists of 55 professionals, of which 19 are professional engineers. Twelve of our staff members are originally from St. Augustine and/or still reside in the County.

#### Capabilities

We are a full-service engineering firm and as such can address a variety of transportation needs. We have the in-house capability to work on any type of roadway project including city streets and local roads; urban, regional and national highway systems; access management systems; and interchanges. Because we work daily on transportation projects involving state or federal funds, we fully understand—and participate in—the funding, programming, permitting, approval, and implementation of these facilities. Our capabilities include:

- Roadway and intersection analysis and design
- Drainage analysis and design
- Utility analysis and design
- Traffic control analysis and design
- Safety and crash analysis
- Traffic analysis and modeling
- Project development and environmental (PD&E) studies
- Corridor studies
- Structures and retaining wall design
- Bikeways, greenways, and pedestrian facilities
- Limited access highway design
- Innovative interchange design

#### Key Personnel

Our team is comprised of talented professionals experienced in every discipline necessary to complete this project. We have the knowledge, skill, and ability to bring innovative techniques and solutions to this two- to four-lane, urban roadway widening opportunity. We blend talent, experience, and innovation with an in-depth understanding of your needs and desires.

We assembled a strong team of technical experts who are committed to successful project delivery and client satisfaction. We have carefully selected team members based upon their

extensive roadway design and St. Johns County experience that is the most relevant for this project. This team has successfully completed a wide variety of similar projects including SR 21 Widening, SR 200 Widening, New World Avenue, SR 50 Widening, and Kernan Boulevard.



#### **Project Manager and Engineer of Record**

We recognize the importance of effective team coordination and experienced project leadership as it relates to project success and client satisfaction. This recognition includes understanding your needs while delivering products of the highest quality. We have specifically selected **Walter Nemecek, PE**, as our Project Manager and primary point of contact. Walter has more than 19 years of hands-on experience managing roadway widenings and working with you. He currently manages Arcadis' Continuing Contract for Engineering Services with you and has completed numerous task work orders. He has seen more than 10 St. Johns County projects through construction and has worked with all your project managers including project manager for this project, Nick Perpich. He knows your standards and how to get a project built in St. Johns County. With Walt, there is no learning curve needed, and he can begin working on CR 210 immediately. You can depend on him to provide the same dedicated service and to continue as your trusted advisor. His entire career has been spent on roadway improvements and he completed seven roadway widenings in the past 10 years alone. Having grown up in St. Augustine and over 100 family members still living in the area, Walt has first-hand experience with the issues facing you and is 100% committed to the success of the CR 210 project.

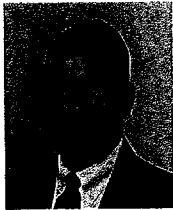

#### **Principal-in-Charge**

For nearly 30 years, **Gene Howerton, PE**, has been working with you to improve mobility and safety. He has been integral to the successful relationship we have with you. Gene is intimately involved in all projects completed for you. As principal-in charge, he makes certain necessary resources are allocated to complete the CR 210 project. When necessary, he also provides an additional senior review of all documents including plans prior to submittal. Gene's expertise includes 3D design, roadway, drainage design, maintenance of traffic, and project management.



#### **Quality Assurance and Quality Control**

**Gary Sowell, Jr., PE**, serves as the Florida transportation Quality Assurance Manager. His experience ranges from complex multi-interchange projects to small enhancement projects. Management responsibilities include project procurement, budgeting, oversight, personnel management, quality control, and quality assurance. Design responsibilities include data collection, roadway/rail/site design, maintenance of traffic design, stormwater/drainage design, modeling, and permitting, safety analysis, planning/studies, and plans production. Gary grew up in St. Augustine and has 18 years of experience working with your standards and understands local preferences and issues..



#### **Roadway Design**

**Roman Blanco, PE**, is the roadway design engineer for the project. He has 17 years of experience in roadway and intersection design, maintenance of traffic design, and project management. Roman has been a St. Augustine resident his entire life and has a strong understanding of issues along the project corridor.

**Local Experience** - Information on each of these firms follows this section.

<b>Project Name</b>	<b>Description</b>
US 1 and SR 312 Intersection Improvements	Expansion of the intersection including dual left turn lanes and a designated right turn lane for each of the four legs, widening to accommodate designated bike lanes, a new northbound through lane, a new right turn lane, extending the left turn bay on the SR 312 east approach, a new right turn lane and bike lane on SR 312 at Old Moultrie Road, and nine new signals at the affected intersections.
Dobbs Road/Kings Road/Kings Estate Road Intersection Realignment	Improvements were designed to alleviate traffic and improve sight distance and safety. We developed five alternatives including roundabout alignments and signalized intersection alternatives. Design was expanded to include drainage improvements, intersection modeling, and a 500-acre drainage basin.
Race Track Road Turn Lane	Design of a 900-foot turn lane to alleviate congestion at the intersection with Durbin Creek Boulevard. Mast arms and utilities were relocated outside of the new clear zone.
Holmes Boulevard Corridor Study and Design	A 4-mile study for an alternate corridor design for SR 312 bypass involving a new two-lane road. We prepared plans for the construction of a 1.2-mile section from a partial two-lane rural section to a two-lane, half urban, half rural section. Tasks included roadway design, drainage, permitting, signalization, right-of-way impacts, phased design, and construction cost estimates.
Usina Boat Ramp Pier	Design of a 134-foot timber pier with a floating dock, fish cleaning station, complete lighting, and handicap access points.
CR 13 Culvert Extensions	Design and permitting of 25 cross drain extensions to remove drop-off hazards from the clear zone. Tasks include geometric and structural design, ditch re-grading, drainage modeling, typical section improvement, and maintenance of traffic. Design also included a Nutrient Separating Baffle Box to provide pollutant removal credits for the County.
Hazard Mitigation Grant Fund Signal Replacements	Design of three signal replacements as part of a Federal Emergency Management Agency (FEMA) grant located on Health Park Boulevard at Flagler Hospital, SR A1A and Solano Road, and SR A1A and Coastal Highway. Mast arm locations accommodate the current signal configuration, avoid major underground utilities, and avoid high-voltage overhead transmission lines.
Greenbriar Road	Design of 5 miles of two-lane rural roadway with stormwater systems designed for the ultimate four-lane section.
Greenbriar Sidewalk	Design of a 500-foot sidewalk adjacent to Switzerland Point Middle School.
International Golf Parkway & I-95 Interchange	Planning and design of a diamond interchange for International Golf Parkway and I-95. The interchange included over a mile of four-lane, urban construction along International Golf Parkway.
Ashford Mills DRI	Arcadis prepared the original Development of Regional Impact (DRI) for over 2,500 residential units as well as retail and general office space. We have detailed information of the drainage scheme in the development.

### Organizational Chart

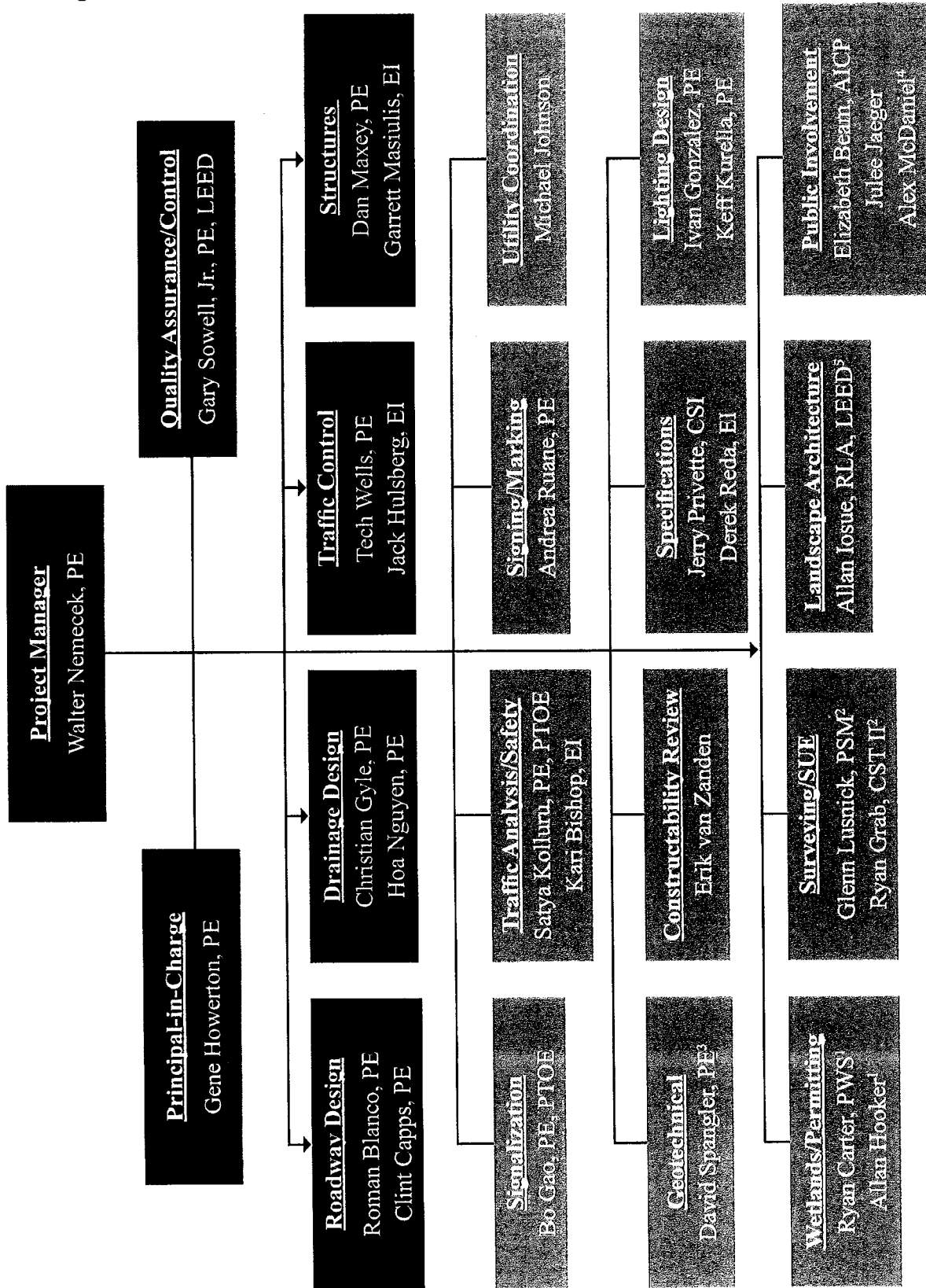

- Subconsultants**
- 1. Carter Environmental
  - 2. DRMP
  - 3. Ellis & Associates
  - 4. GameSim
  - 5. Pond and Company

## WALTER NEMECEK, PE

### Project Manager



*Walter Nemecek, is a seasoned roadway and drainage engineer who has completed and built 10 projects with you.*

#### EDUCATION

- BS, Civil Engineering, University of Florida

#### YEARS OF EXPERIENCE

- Total - 19
- With Arcadis - 19

#### PROFESSIONAL REGISTRATIONS

- Professional Engineer: FL

#### PROFESSIONAL ASSOCIATIONS

- American Society of Highway Engineers
- Institute of Transportation Engineers

#### Overview

Mr. Nemecek has extensive roadway management and design experience. His engineering proficiency has been demonstrated on projects ranging from complex limited access roadway design to pedestrian facilities and intersection improvements. He has led 10 intersection improvement projects and six roadway widening projects. As Project Manager, he works closely with all team members to promote open and constant communication. He has demonstrated industry leading drainage expertise in stormwater design, planning and permitting utilizing the latest adopted pollution removal techniques and practical design elements to provide the most economical long-term solutions.

#### Project Experience

##### US 1 and SR 312 Intersection Improvements

St. Johns County, Florida

Engineer of Record and Project Manager: Design of dual left turn lanes and a designated right turn lane for each of the four legs. Design responsibilities included horizontal and vertical geometry, drainage structures, signal design, striping plans, special intersection geometry, maintenance of traffic design, and plan production.

##### Dobbs Road/Kings Road/Kings Estate Road Intersection

St. Johns County, Florida

Engineer of Record: Realignment of the offset intersection. An elaborate drainage model, conveyance system and stormwater facility was designed to alleviate historical flooding along Dobbs Road.

##### SR 21 (Blanding Boulevard)

FDOT District 2, Clay County, Florida

Engineer of Record and Project Manager for the drainage design and permitting corresponding to widening 4 miles of SR 21 from a four-lane rural to six-lane urban arterial roadway. Our design responsibilities include the drainage collection system, pond siting, stormwater treatment facilities, USACOE & SJRWMD permitting, Intelligent Transportation Systems, Lighting, and Quality Control.

##### New World Avenue Extension

City of Jacksonville, Florida

Project Manager for design of a four-lane, urban, divided roadway, sidewalks, and bike lanes. We performed the design of roadway, intersections, and lighting, as well as the design and permitting of the stormwater treatment, collection, and outfall systems that tie into the Cecil Commerce Center drainage scheme.

## GARY SOWELL, JR., PE, LEED AP BD+C

### Quality Assurance/Quality Control



*Gary Sowell serves as Arcadis' Quality Control Reviewer for all roadway designs developed by the Jacksonville office.*

#### EDUCATION

- BS, Civil Engineering, University of Florida

#### YEARS OF EXPERIENCE

- Total - 18
- With Arcadis - 15

#### PROFESSIONAL REGISTRATIONS

- Professional Engineer: FL, GA
- LEED Accredited Professional: Building Design and Construction

#### PROFESSIONAL ASSOCIATIONS

- Florida Association of County Engineers and Road Superintendents

#### Overview

Mr. Sowell's experience ranges from complex, multi-interchange projects to small, enhancement projects. Management responsibilities include project procurement, budgeting, oversight, personnel management, quality control, and quality assurance. Design responsibilities include data collection, roadway/rail/site design, maintenance of traffic design, stormwater/drainage design, modeling, and permitting, safety analysis, planning/studies, and plans production. Project types include planning, Design-Bid-Build, Design-Build, and Public-Private Partnership (P3).

#### Project Experience

##### Holmes Boulevard Corridor Study and Design

St. Johns County Public Works, St. Johns County, Florida

Senior Design Engineer for the construction of a 1.2-mile section from a partially two-lane rural section and partially undeveloped land to a two-lane, half urban, half rural section. Design also included the realignment of a 0.4-mile section of an intersecting side street, for increased safety.

##### Old Kings Road (Baymeadows Road to Powers Avenue)

City of Jacksonville, Duval County, Florida

Design Engineer. Design for the widening of a 1.6-mile section from a two-lane rural section to a three-lane urban section with bicycle lanes.

##### Hodges Boulevard

City of Jacksonville, Duval County, Florida

Senior Design Engineer. Design for the widening of a 1.1-mile section from a two-lane to a four-lane rural section.

##### Kernan Boulevard Widening

City of Jacksonville, Duval County, Florida

Engineer of Record for the widening of a two-lane, 6.5-mile rural section to a six-lane (approximately 5.0 miles) and four-lane (approx. 1.5 mile) urban section. The design incorporated a pedestrian/bicycle multi-use path and included interaction with two interchanges.

##### SR 200 Widening Design-Build

FDOT, District Two, Nassau County, Florida

Senior Design Engineer. Design for the widening of approximately 6 miles of SR 200 from two to four lanes of urban roadway.

## ROMAN BLANCO, PE

### Roadway Design



*A lifelong resident of St. Johns County, Roman Blanco has more than 17 years of experience in roadway widening projects.*

#### EDUCATION

- BS, Civil Engineering, University of Florida

#### YEARS OF EXPERIENCE

- Total - 17
- With Arcadis - 17

#### PROFESSIONAL REGISTRATIONS

- Professional Engineer: FL

#### Overview

Mr. Blanco is a professional civil engineer with 17 years of experience specializing in roadway design. His responsibilities include roadway design, interchange layout, maintenance of traffic plans, drainage design, pavement design, pedestrian facility design, parking facility design, permitting, project coordination, and quality control. Mr. Blanco has been project manager or engineer of record of nearly 20 arterial roadway widening projects for FDOT.

#### Project Experience

##### Interchange at I-95 and St. Augustine Road

Flagler Development Company, Duval County, Florida

Project Engineer: A "fast-track" project for the design and permitting of a new partial cloverleaf interchange with two diagonal ramps and two loop ramps, widening St. Augustine Road from an existing two-lane rural section to a four-lane divided urban section, addition of acceleration and deceleration lanes along I-95 and the construction of stormwater treatment facilities. Design responsibilities included horizontal and vertical geometry design of the roadway and interchange, maintenance of traffic plans, and quality control.

##### SR 482 Widening (Sand Lake Road)

FDOT, District 5, Orange County, Florida

Project Manager: Widening of a 2.9-mile segment from a four-lane (urban and rural) to a six-lane (urban, rural, and suburban) section. Including improvements at the SR 435 (Kirkman Road) interchange and widening of 0.4 miles of International Drive. Design responsibilities included roadway design and project management.

##### SR 35 Widening (Lion Street to NE 110 Road)

FDOT, District 5, Sumter County, Florida

Project Manager: Widening and permitting of a 2.8-mile, two-lane rural roadway to a four-lane urban/suburban roadway. Responsibilities included project coordination, quality control, budget and schedule control and overall management of design and permitting activities.

##### SR 50 Widening

FDOT, District 5, Orange County, Florida

Roadway Design: Design of a 3.5 mile roadway widening project from four-lane rural roadway to a six-lane urban roadway in a highly urbanized area.

## CLINT CAPPS, PE

### Roadway Design



*Clint Capps has more than 7 years of experience as a roadway designer.*

#### EDUCATION

- BS, Civil Engineering, University of North Florida

#### YEARS OF EXPERIENCE

- Total - 7
- With Arcadis - 7

#### PROFESSIONAL REGISTRATIONS

- Professional Engineer: FL

#### Overview

Mr. Capps has experience in the design of roadway and transit projects in Florida and Texas. His design responsibilities include data collection, roadway horizontal and vertical alignment, proposed cross sections, maintenance of traffic plans, stormwater design and modeling, development of calculation books for stormwater facilities, acquisition of required governing agency permits, parking facility design, and pedestrian facility design and safety analysis.

#### Project Experience

##### Dobbs Road/Kings Road/Kings Estate Road Intersection

St. Johns County, Florida

Design Engineer: Realignment of an offset intersection at Dobbs Road, Kings Estate Road, and Kings Road. In addition to intersection improvements, an elaborate drainage model, conveyance system, and stormwater treatment facility was designed to alleviate historical flooding along Dobbs Road. Responsibilities included erosion control design, drainage design, and permitting.

##### SR 21 (Blanding Blvd - Black Creek Bridge to Old Jennings Road)

FDOT, District 2, Clay County, Florida

Design Engineer: Drainage design and permitting corresponding to widening 4 miles of SR 21 from a four-lane rural to six-lane urban arterial roadway. Responsibilities include drainage collection system design, pond siting, stormwater treatment facility design, vertical geometry, erosion control design, lighting plans, and St. Johns River Water Management District permitting.

##### US 1 and SR 312 Intersection Improvements

St. Johns County, Florida

Design Engineer for dual left turn lanes and a designated right turn lane, bike lanes, a new northbound through lane, a new right turn lane for Bartola Genovar Road, a left turn bay on the SR 312 east approach, a new right turn lane and bike lane on SR 312 at Old Moultrie Road, and nine new mast arms.

##### Jacksonville International Airport and Airport Road PD&E

FDOT, District 2; Jacksonville, Florida

Design Engineer: Preliminary engineering concepts and operational analysis for this Project Development and Environmental (PD&E) study that involves development of alternatives to fix existing operational analysis problems within the I-95/SR 102 Interchange area. Responsible for roadway design for interim and ultimate concepts. Developed exhibits for public meetings.

## CHRISTIAN GYLE, PE

### Drainage Design



*Christian Gyle has served as project engineer for six of your projects and modeled the CR 210 drainage basins as part of the CR 13 Culvert Extension.*

#### EDUCATION

- BS, Civil Engineering, University of Florida

#### YEARS OF EXPERIENCE

- Total - 12
- With Arcadis - 12

#### PROFESSIONAL REGISTRATIONS

- Professional Engineer: FL

#### Overview

Mr. Gyle is experienced in the design of roadway and drainage projects. His design responsibilities include data collection, roadway horizontal and vertical alignment, proposed cross sections, maintenance of traffic plans, signal design, signing and marking design, stormwater design and modeling, development of calculation books for stormwater facilities, stormwater permitting, and pedestrian facility design and safety analysis.

#### Project Experience

##### CR 13 Culvert Extensions

St. Johns County, St. Augustine, Florida

Project Engineer: Design and permitting of 25 cross drain extensions to remove drop-off hazards from the clear zone, based on FDOT RRR criteria. Design responsibilities included geometric and structural design for each extension, ditch re-grading, drainage modeling, typical section improvement and maintenance of traffic.

##### US 1 and SR 312 Intersection Improvements

St. Johns County, St. Augustine, Florida

Project Engineer: Design of dual left turn lanes and a designated right turn lane, bike lanes, a new northbound through lane, a new right turn lane for Bartola Genovar Road, a left turn bay on the SR 312 east approach, a new right turn lane and bike lane on SR 312 at Old Moultrie Road, and nine new mast arms. Design responsibilities included geometry, drainage structures, signal design, striping plans, special intersection geometry, and maintenance of traffic design.

##### Wind Retrofit Signal Improvements

St. Johns County, St. Augustine, Florida

Project Engineer: Relocation of mast arms at Solano Road, Coastal Highway and Health Park Boulevard to accommodate the current signal configuration. Design responsibilities included signal configuration, drainage design, mast arm structural design, utility coordination, and grant administration.

##### SR 21 (Blanding Blvd - Black Creek Bridge to Old Jennings Road)

FDOT, District 2, Clay County, Florida

Drainage design and permitting for widening of 4 miles of SR 21 from a four-lane rural to six-lane urban arterial roadway. Design responsibilities include the drainage collection system design, pond siting, stormwater treatment facility design, US Army Corps of Engineers and St. Johns River Water Management District permitting.

## HOA NGUYEN, PE

### Drainage Design

*Hoa Nguyen has more than 16 years of roadway and drainage design experience.*

#### EDUCATION

- BS, Civil Engineering, University of Florida

#### YEARS OF EXPERIENCE

- Total - 18
- With Arcadis - 18

#### PROFESSIONAL REGISTRATIONS

- Professional Engineer: FL

#### Overview

Mr. Nguyen serves as project engineer on roadway and land development projects. Design responsibilities include data collection, roadway horizontal and vertical alignment, signing and pavement marking plans, proposed cross sections, maintenance of traffic plans, stormwater design and modeling, pedestrian facility design and safety analysis, parking facility design, and acquisition of required governing agency permits.

#### Project Experience

##### SR 9B Design-Build

FDOT, District 2, Duval County, Florida

Project Engineer: Design and permitting of a new partial cloverleaf interchange and roadway design of SR 9B, and widening of US 1 (SR 5). Design responsibilities included roadway, drainage, maintenance of traffic plans, utility coordination, and cost estimates.

##### I-95 Overland Bridge Replacement Study

FDOT, District 2, Jacksonville, Florida

Project Engineer: Project includes reconstruction of I-95 from a five-to six-lane section, seventeen bridge widening/replacements, creating a northbound and southbound Collector-Distributor system and a new interchange with Atlantic Blvd. /Philips Hwy. Design responsibilities included roadway, drainage, permitting, and QA/QC.

##### SR 482 (Sand Lake Road)

FDOT, District 5, Orange County, Florida

Project Engineer for a 3.13-mile widening from a four-lane rural/urban to a six-lane rural/urban/suburban section. Design responsibilities included roadway, drainage, permitting, and QA/QC.

##### SR 105/A1A Ft. George Inlet (Huguenot Memorial Park to Little Talbot Island State Park)

FDOT, District 2, Duval County, Florida,

Design Engineer: Roadway and approach design of a new replacement bridge over Ft. George Inlet. Design responsibilities included roadway, maintenance of traffic, drainage, and utility coordination.

##### SR 520 (Tosahatchee State Preserve to the St. Johns River)

FDOT, District 5

Design Engineer: Design engineer on a 2.2-mile widening design project from a two-lane rural to a four-lane rural section. Design responsibilities included roadway, drainage, maintenance of traffic, and quantity computation manual preparation.

## TECH WELLS, PE

### Traffic Control



*Tech Wells has more than 13 years of experience in roadway and drainage design.*

#### EDUCATION

- BS, Civil Engineering, Florida State University

#### YEARS OF EXPERIENCE

- Total - 13
- With Arcadis - 7

#### PROFESSIONAL REGISTRATIONS

- Professional Engineer: FL

#### Overview

Mr. Wells has experience in the design of roadway and drainage projects. Design responsibilities include roadway horizontal and vertical alignment, signing and pavement marking plans, proposed cross sections, maintenance of traffic plans, data collection, stormwater design and modeling, and the acquisition of required governing agency permits.

#### Project Experience

##### I-95/SR 9B Interchange Design-Build

FDOT District 2, Jacksonville, Florida

Design Engineer: Design and permitting of SR 9B with interchanges at US 1 and I-95. Project also includes widening of I-95 through the project limits and construction of a Sound Barrier at the I-95 interchange. Project responsibilities include drainage design using ASAD and ICPR, and securing a permit.

##### Plantation Oaks Boulevard over SR 23 Design-Build

FDOT District 2, Clay County, Florida

Design Engineer: Replacement of existing signalized at-grade intersection with two new overpass structures, including substantial lengths of MSE walls to minimize additional right-of-way needs. The recently completed project was valued at \$7.3 M. These improvements were selected for funding under the American Recovery and Reinvestment Act of 2009 (ARRA).

##### Beach/Kernan Interchange Design-Build

Jacksonville Transportation Authority, Jacksonville, Florida

A new six-lane urban interchange at the Beach Boulevard (US-90) and Kernan Boulevard intersection. The structure consists of a 515-foot-long three-span continuous steel plate girder bridge located on a 2,292-foot radius horizontal curve. The project, valued at \$32 M, includes a 12-foot multi-use path, sidewalks, signalization, utility relocations and landscaping.

##### SR 200 Widening Design-Build

FDOT District 2, Yulee, Florida

A 5-mile roadway widening and reconstruction project from a four-lane rural roadway to a six-lane urban roadway. Design responsibilities also included the design of nine stormwater treatment ponds and associated drainage conveyance systems.

## DAN MAXEY, PE

### Structures Design



*Dan Maxey has more than 33 years of structural design experience from box culverts to highway bridges and major river crossings.*

#### EDUCATION

- BS, Civil Engineering, University of Tennessee

#### YEARS OF EXPERIENCE

- Total - 33
- With Arcadis - 7

#### PROFESSIONAL REGISTRATIONS

- Professional Engineer: FL, GA, MS, NC, TN

#### PROFESSIONAL ASSOCIATIONS

- American Society of Civil Engineers
- American Society of Highway Engineers

#### Overview

Mr. Maxey is a senior structures engineer with more than 33 years of experience including the design of concrete structures, horizontally curved steel plate and box girders, pre-stressed superstructure and substructure design. He is versed in design of highway-related appurtenances such as retaining walls, box culverts, overhead sign structures, and details for widening of existing structures.

#### Project Experience

##### SR 9B from I-95 to North of US 1 Design-Build

FDOT, District 2, Jacksonville, Florida

Structures Design Manager: This project extends SR 9B for 2 miles south on new alignment and provides a new system-to-system interchange at the junction with I-95. Project includes the design and construction of 2 miles of new limited access highway with two interchanges, eight bridges, 2 million cy of embankment, over 200,000 sf of sound walls and 15,000 lf of storm drainage along with widening 1 mile of I-95.

##### I-95 Widening at CR 210 Interchange Design-Build

FDOT, District 2, St. Johns County, Florida

Structures Design Manager for widening of a 9-mile section of I-95 from four to six lanes. The project involves replacement of the bridge structures at the I-95/CR 210 Interchange, detailed traffic control plans, temporary sheeting, lighting plans, signalization at CR 210 and extensive coordination with St. Johns County's planned future improvements to CR 210.

##### University Boulevard Bridge Design-Build

FDOT District 2, Jacksonville, Florida

Structures Designer: Replaces the structurally deficit bridge over the Arlington River with a two-lane bridge consisting of a single 12-foot travel lane in each direction, bike lanes and sidewalks. Includes designing a temporary Acrow bridge on a modified alignment to simplify maintenance of traffic and allow construction from one trestle between the temporary and proposed bridge.

##### SR 9A/I-295/I-95 South Interchange

FDOT District 2, Duval County, Florida

Project Manager and Structures Design Engineer: Three ramp flyovers of post-tensioned segmental concrete construction, three overpass structures consisting of the new Florida pre-stressed concrete "U" beams and two creek crossing structures of conventional AASHTO concrete girders.

**BO GAO, PE, PTOE**  
Signalization



*Bo Gao has more than 16 years of traffic management experience and has retimed and optimized more than 500 signals.*

**EDUCATION**

- MS, Civil Engineering, University of South Florida
- BS, Traffic Engineering, Beijing University of Technology

**YEARS OF EXPERIENCE**

- Total - 16
- With Arcadis - 1

**PROFESSIONAL REGISTRATIONS**

- Professional Engineer: FL, AZ, CO, TX
- Professional Traffic Operations Engineer

**PROFESSIONAL QUALIFICATIONS**

- IMSA Traffic Signal Technician Level II

**Overview**

Mr. Gao has over 16 year of experience in systems engineering, Intelligent Transportation Systems (ITS) design and system integration, communications, signal timing development, adaptive signal control implementation and traffic signal control software development. His traffic management systems experience includes development, installation, operation and maintenance of central traffic signal control and freeway management systems. These experiences includes development of Siemens TACTICS central signal control system and M50 controller firmware, installation and maintenance of TransCore TransSuite TCS and FMS systems with different hardware platforms such as Siemens M50, Econolite ASC/3, and McCain ATC. Mr. Gao's ITS design and implementation experience includes self-healing fiber optic communication system, CCTV, DMS, BlueTooth/WiFi Data Reader, wireless radio, video display wall, and vehicle detections.

**Project Experience**

**Soutel Drive Traffic Signal Warrant Study**  
Confidential Client, Jacksonville, FL

A traffic impact and signal warranty study for a new signal on Soutel Drive at the entrance to the Martin Marietta facility. The new signal is in response to an increase of 600 additional trucks accessing an adjacent facility from Soutel Drive. Construction is scheduled for late 2016.

**Active Arterial Management Phase II Design**  
FDOT, District 5, Orlando, FL

Project Manager for the design of the arterial management system on six corridors across multiple public agencies including Seminole County, City of Orlando and Orange County. The system is one of the vital components of the District TSM&O program and provides travel time, Origin-Destination information, traffic volume and speed data which can be used by FDOT RTMC timing engineers and operators to conduct arterial performance measures and signal timing adjustments.

**Tatum Blvd Signal Retiming (30 intersections)**  
Phoenix, Arizona

Project Manager for timing plan development and implementation using central software, time-of-day (TOD) commands evaluation, fine tuning using dynamic time space diagram, and before-after travel time studies via Tru-Traffic software. Benefit/Cost (B/C) analysis performed using traffic safety and operational data.

**SATYA KOLLURU, PE, PTOE**

Traffic Analysis and Safety



*Satya Kolluru has more than 12 years of experience in traffic analysis with a focus on safety and forecasting.*

**EDUCATION**

- MS, Transportation Engineering, University of Cincinnati
- BS, Civil Engineering, Andhra University, Visakhapatnam, AP (India)

**YEARS OF EXPERIENCE**

- Total - 12
- With Arcadis - 2

**PROFESSIONAL REGISTRATIONS**

- Professional Engineer: FL, OH
- Professional Traffic Operations Engineer

**PROFESSIONAL ASSOCIATIONS**

- Institute of Transportation Engineers

**Overview**

Mr. Kolluru has more than 12 years of experience in traffic operations and safety, travel demand modeling, geometric design, and environmental impact analysis. He is experienced in conducting preliminary systems planning, traffic impact analyses and extremely skillful in the use of traffic simulation software. Mr. Kolluru is skilled in traffic signal optimization techniques, traffic signal design, maintenance of traffic sequencing, signing and pavement marking design, and traffic control plans. He is highly experienced in ArcGIS applications to civil engineering designs and planning. His strengths involve traffic modeling, design software, problem solving skills, planning, organization and report writing.

**Project Experience**

**Jacksonville International Airport and Airport Road PD&E**  
FDOT, District 2, Jacksonville, FL

Project Manager for development and completion of preliminary engineering concepts and operational analysis that involves alternatives to fix existing operational analysis problems within the I-95/SR 102 Interchange area.

**Argyle Forest Boulevard Traffic and Safety Study**

North Florida Transportation Planning Organization, Jacksonville, FL  
Project Engineer for traffic and safety study within the Argyle Forest Boulevard region. Designed various roadway concepts to relieve existing traffic congestion. Recommended the development of a safety campaign to address aggressive driving within the region.

**Regional Strategic Safety Plan**

North Florida Transportation Planning Organization, Jacksonville, FL  
Project Engineer responsible for the preparation of a Regional Strategic Safety Plan for the North Florida region. Performed safety analysis using ArcGIS and identified crash hot-spot locations.

**St. Augustine Mobility Institute**

North Florida Transportation Planning Organization, Jacksonville, FL  
Project Engineer responsible for the operational analysis and public information campaign material for the project. Conducted public information campaigns within St. Augustine providing information on the three heavily congested corridors in the region.

## ANDREA RUANE, PE

### Signing and Marking



*Andrea Ruane is a transportation engineer with more than six years of experience.*

#### EDUCATION

- ME, Environmental Engineering Sciences, University of Florida
- BS, Civil Engineering, University of Florida

#### YEARS OF EXPERIENCE

- Total - 6
- With Arcadis - 6

#### PROFESSIONAL REGISTRATIONS

- Professional Engineer: FL

#### PROFESSIONAL ASSOCIATIONS

- American Society of Highway Engineers

#### Overview

Ms. Ruane has six years of transportation engineering experience. She has experience in roadway design, signing and marking, and maintenance of traffic design. In addition, Ms. Ruane provides GIS mapping services.

#### Project Experience

##### State Road 9B from I-95 to CR 2209 Design-Build

FDOT, District 2, Duval and St. Johns Counties, FL  
New alignment of SR 9B from CR 2209 to the existing SR 9B interchange at I-95. Project responsibilities included preliminary signing design and estimation of signing quantities, erosion control plans, typical section package, and pavement design package.

##### SR 9B from I-95 to North of US 1 Design-Build

FDOT, District 2, Duval and St. Johns Counties, FL  
Assisted in the design of a new partial cloverleaf interchange, a system to system interchange, and the SR 9B mainline from US-1 to I-95. Project responsibilities included signing and pavement marking plans, interchange vertical alignment, sound wall design, maintenance of traffic, geotechnical coordination, design variance submittals, I-95 milling and resurfacing plans, and US-1 drainage design.

##### CR 13 Culvert Extensions

St. Johns County, Florida  
Project Engineer: This project included the evaluation, design and permitting of 35 culvert extensions to remove drop-off hazards from the clear zone based on FDOT RRR criteria. Responsibilities included design of maintenance of traffic plans for culvert replacement.

##### SR 200 (A1A) From West of Rubin Rd to East of CR 107/Scott Rd

FDOT, District 2, Nassau County, FL  
Project includes 5 miles of roadway widening and reconstruction from a four-lane rural roadway to a six-lane urban roadway. Project responsibilities included signing design review, GIS work in support of permitting and design, and utility adjustment sheets.

##### SR 482 Widening (Sand Lake Road)

FDOT, District 5  
Project includes widening 2.5 miles of four-lane roadway to six lanes from International Drive to John Young Parkway in Orlando, Florida. Updated signing design to meet current standards and site conditions. Estimated signing and pavement marking quantities.

## MICHAEL JOHNSON

### Utility Coordination



*Michael Johnson is an experienced roadway designer with a focus on utility coordination.*

#### EDUCATION

- AS, University of Florida

#### YEARS OF EXPERIENCE

- Total - 28
- With Arcadis - 28

#### Overview

Mr. Johnson has 28 years of experience in civil design. He has worked on a variety of projects including ITS, complex roadway and drainage design, as well as land development. His experience includes extensive coordination with utility owners for both public and private facilities.

#### Project Experience

##### SR 9B from I-95 to North of US 1 Design-Build

FDOT, District 2, Duval County, Florida, Senior Designer: The project includes constructing a new system-to-system interchange, widening of I-95, and completion of US 1 Interchange, widening I-95, and new freeway alignment for SR 9B. Permitting and Utility coordination and connection drawings were also submitted for final approval.

##### SR 200 Design-Build

FDOT, District 2, Nassau County, Florida

Utility Coordination for widening of 6 miles from two to four lanes. The proposed roadway consists of 2.3 miles of a four-lane divided urban typical section followed by 3.8 miles of a four-lane divided rural typical section. Responsibilities include design of electrical and water utility upgrades and relocation. Also included utility coordination, plans production, permitting and final plans.

##### I-95 Intelligent Transportation System (ITS)

FDOT, District 2, St. Johns County, Florida

Senior Designer for a construction plan set for field equipment, communication and devices along a 34-mile segment that seamlessly integrates with the existing FDOT SunGuide System. The deployment includes freeway and arterial dynamic messaging signs, closed circuit televisions, multi-point vehicle detection systems, and Bluetooth units. Project involves extensive coordination with St. Johns County Public Works Department and other local and Federal agencies. Responsibilities include layout, design and plans production.

##### University Boulevard Bridge Replacement over the Arlington River Design-Build

FDOT, District 2, Jacksonville, Florida

Utility Coordination: Replaces the structurally deficient bridge with a two-lane bridge consisting of a single 12-foot travel lane in each direction, bike lanes and sidewalks. Responsibilities include the design of utility upgrades and relocation as part of the roadway design changes, plans production, permitting and final plans.

## ERIK VAN ZANDEN

### Constructability review

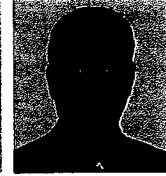

*Erik van Zanden has more than 30 years of experience in roadway design.*

#### EDUCATION

- AA, Jacksonville University/Florida Community College at Jacksonville

#### YEARS OF EXPERIENCE

- Total - 31
- With Arcadis - 30

#### PROFESSIONAL ASSOCIATIONS

- American Public Works Association
- Florida Institute of Consulting Engineers
- Florida Planning and Zoning Association

#### Overview

As a seasoned Project Manager, Mr. van Zanden has overseen many interchange, structural and highway design projects including concept development. He is experienced in all aspects of roadway design including roadway layout and design, permitting, traffic signal design, and signing and pavement marking design. Mr. van Zanden makes certain all designs meet all FDOT and AASHTO standards, while promoting constructability. He works closely with all team members to develop concepts that more than meet the project goals, while providing easy of constructability.

#### Project Experience

##### Holmes Boulevard Corridor Study and Design

St. Johns County, Florida

Phase I consisted of a 4 mile study for an alternate corridor design to the SR- 312 bypass in St. Augustine. The conceptual study involved a proposed new two lane road connecting Fourmile Road to Kings Road (CR 214). Phase II responsibilities included roadway design, drainage, permitting, and signalization, right-of-way impacts, phased design and construction cost estimates. This project was successfully completed under budget and was the first new roadway to be constructed in St. Johns County in more than 20 years.

##### SR 9B from I-95 to North of US 1 Design-Build

FDOT, District 2, Jacksonville, Florida

Design Project Manager: This innovative project includes the construction of 2 miles of new limited access highway including two new interchanges, eight bridges, 2 million cy of embankment, over 200,000 sf of sound walls and 15,000 LF of storm drainage along with widening 1 mile of I-95.

##### St. Augustine Road and I-95 Interchange

Flagler Development Corporation, Jacksonville, Florida

Design Project Manager: Responsibilities included overseeing all design aspects of layout, bridge design coordination, aesthetic design and coordination, landscape design coordination, as well as assistance with bidding, construction observation and administration. Improvements include a new partial cloverleaf interchange with two diagonal ramps and two loop ramps, widening St. Augustine Road from an existing two-lane rural section to a four-lane divided urban section, addition of acceleration and deceleration lanes along I-95 and the construction of stormwater treatment facilities.

**JERRY PRIVETTE**  
Specifications



*Jerry Privette brings more than 45 years of engineering experience.*

**YEARS OF EXPERIENCE**

- Total - 45

**Overview**

Mr. Privette is responsible for preparation of specifications, bidding and contract documents, cost estimates and construction schedules for civil engineering projects including private, state, federal, residential and industrial land development and transportation projects.

**Project Experience**

**Roadway Projects**

- St. Johns County Public Works Department
- Florida Department of Transportation, Districts 2 and 5
- City of Jacksonville Public Works Department
- Jacksonville Transportation Authority
- University of North Florida
- City of Palm Coast

**Water, Sanitary Sewer and Stormwater Projects**

- St. Johns County Utility Department
- City of St. Augustine
- City of St. Augustine Beach
- JEA Water & Sewer Unit

**Commercial, Industrial and Residential Projects**

- St. Johns County Public Schools
- City of Jacksonville Parks & Recreation Department
- Duval County Public Schools
- Baker County Public Schools
- Cecil Commerce Center
- Lowes
- Home Depot
- Wal-Mart
- Publix
- Winn-Dixie
- Costco
- CVS
- Target
- Grand Haven Community Development District
- Sandy Creek Community Development District
- Kimco Developers
- Oare Associates LLC
- Kings Pointe LLC

**IVAN GONZALEZ, PE**  
Lighting



*Ivan Gonzalez has more than 40 years of electrical engineering design.*

**EDUCATION**

- BSEE, Electrical Engineering, Louisiana State University
- MBA, Industrial Management, Inter-American University

**YEARS OF EXPERIENCE**

- Total - 40
- With Arcadis - 12

**PROFESSIONAL REGISTRATIONS**

- Professional Engineer: FL, CA, GA, LA, NC, PR, TN, TX

**PROFESSIONAL ASSOCIATIONS**

- Institute of Electrical and Electronics Engineers (IEEE)
- International Society of Automation (ISA)
- IEEE Power Engineering Society

**Overview**

Mr. Gonzalez has more than 40 years experience in project management, engineering design and design management. His experience includes electrical design of highway ITS and roadway lighting, municipal water treatment facilities, industrial facilities, and Department of Defense and Other U.S. Government Federal Facilities. He has performed master planning and design for multiple classes of facilities incorporating medium voltage looped /redundant configurations, redundant low voltage systems, multiple utility source systems, high voltage and medium voltage substations, power generator paralleling and emergency systems for municipal and industrial projects, and updating of complex electrical systems on a regular basis.

**Project Experience**

**SR 9 (I-95) Overland Bridge Replacement Study**

FDOT, District 2, Jacksonville, FL

Electrical Design Quality Assurance review for design-build construction packages. The scope included review of power supply systems designed to support roadway lighting and Intelligent Transportation Systems Packages were submitted in multiple formats including 90%, 100%, and Final Submittals. Tasks included review and monitoring implementation of review comments.

**South Pointe Streetscape Improvements Phase II**

City of Miami Beach, FL

Electrical Engineer: Street lighting design performing streetscape lighting upgrades throughout City streets and alleys. Design scope covered footcandle lighting level calculations, pole lighting layout, pole foundation design, power distribution, luminaire selection, controls, and existing conditions assessment for power facilities enhancements. More than 100 light poles were included as part of the scope.

**Master Plan Implementation**

Port of Miami, Florida

Electrical Design Manger: Projects included parking lot lighting for administrative employee and visitor areas; replacement of Port Entry Guard Gates and inspection facility; security systems for passenger terminals and administrative buildings. This project enhanced access security and interoperability of multiple port systems to meet long range Master Planning objectives.

## ELIZABETH BEAM, AICP

### Public Involvement



*Elizabeth Beam has more than 28 years of experience in public involvement and stakeholder engagement.*

#### EDUCATION

- MS, Environmental Science, Drexel University
- BA, Urban and Regional Planning, University of Illinois, Urbana

#### YEARS OF EXPERIENCE

- Total - 28
- With Arcadis - 5

#### PROFESSIONAL REGISTRATIONS

- American Institute of Certified Planners
- Envision Sustainability Professional

#### PROFESSIONAL ASSOCIATIONS

- American Planning Association

#### Overview

Ms. Beam is responsible for National Environmental Policy Act (NEPA) documentation including, Environmental Impact Statement (EIS)/Environmental Assessment (EA) preparation, Needs Analysis, and Alternatives Analysis along with Phase I/Phase II Environmental Site Assessments (ESAs). She is also involved in land use analysis, site redevelopment analysis, socio-economic impact analysis, zoning map amendments and fiscal impact analysis, single-family, multi-family and mixed-use project designs, conservation planning, landscape design, and project evaluation for compliance with local, county, and state requirements and regulations.

#### Project Experience

**I-95 at Gateway Boulevard and Boynton Beach Boulevard PD&E**  
FDOT District 4, Palm Beach County, Florida  
Environmental and Public Involvement Lead: Study to develop alternatives for the highly congested and adjacent interchanges in South Florida. Interchanges are constrained by limited right-of-way and adjacent railroad tracks. Concepts must integrate into the future managed lanes for I-95.

#### CR 390 PD&E Study

FDOT District 3, Bay County, Florida  
Public Involvement Lead: This PD&E study develops alternatives for the widening of CR 390 between SR 77 and US 231 to improve capacity and traffic operations at major intersections in a 4-mile suburban segment of Bay County. It includes concept development, environmental studies and documentation, design traffic technical report, public involvement to obtain the LDCA.

#### Pete's Highway Environmental Assessment

LADOTD, Livingston Parish, Louisiana  
Project Planner/NEPA Lead: Public/stakeholder outreach, agency coordination, technical document preparation, EA document preparation, Phase I ESA field work, and document/records research.

#### I-210 Cove Lane/Nelson Road Interchange Improvements EA

LADOTD, Calcasieu Parish, Louisiana

Responsible for public/stakeholder outreach, agency coordination, technical workshop preparation, EA document preparation, Phase I Environmental Site Assessment (ESA) field work, document/records research and technical report preparation.

## JULEE JAEGER

### Public Involvement

*Julee Jaeger, a public involvement professional, has over 20 years of experience communicating with the public via websites.*

#### EDUCATION

- BS, Computer Science, University of Nebraska-Lincoln

#### YEARS OF EXPERIENCE

- Total - 19
- With Arcadis - 6

#### PROFESSIONAL TRAINING

- LMS Design and Management
- Software Development
- UNIX Administration
- Database Design and Administration
- Web Administration, Design, and Development
- Mobile App Development
- Human-Computer Interaction and Multimedia Interface Design

#### Overview

Ms. Jaeger can develop a technical solution for almost any client communications problem. She has over 20 years of experience of technical problem solving, developing communications tools, managing projects, as well as developing corresponding graphics, audio, and video. She has expert knowledge in determining audience viewpoint, editing materials for clarity, and creating engaging technologies. Working with our communications group, Mrs. Jaeger also has experience researching and identifying community organizations, and developing strategies to engage these populations.

#### Project Experience

##### Camp Croft Restoration Advisory Board (RAB)

U.S. Army Corps of Engineers, [campcroft.net](http://campcroft.net)

Maintained the website for this munitions response project. Worked to improve the site content, better connecting RAB members, the surrounding community, and the Corps. Developed content to educate the public about munitions response sites.

##### IMPEX Website

IMPEX., Inc., Crawfordsville, Indiana, [ero-crawfordsville-impex.com](http://ero-crawfordsville-impex.com)

Designed a targeted website educating community about a proposed groundwater restriction ordinance. Worked to refine content and design based on legal needs.

##### Lower Passaic River Study Area

Tierra Solutions, Inc., Newark, New Jersey, [passaicremovalaction.com](http://passaicremovalaction.com)

Designed and developed the website for public access, posting news, photos, and near-real-time delivery of site monitoring information. Assisted in document management and editing Phase I Final and Pre-Final Design Analysis documents. Reconciled the Community Health and Safety Plan (CHASP) with the design documents and created interactive documents for community outreach meetings, and continued to develop the CHASP as community needs evolved. Implemented a community comment/inquiry/feedback hotline in three languages.

## SUBCONSULTANT

### Ellis & Associates, Inc. | Geotechnical Engineering

7064 Davis Creek Road | Jacksonville, FL 32256

Phone: 904.880.0960 | Fax: 904.880.0970

www.ellisassoc.com



Ellis & Associates, Inc. (E&A) specializes in Geotechnical Engineering, Construction Materials Engineering, Testing, and Inspection, Environmental Engineering, Construction Engineering Inspection (CEI) and Special Inspection Services. Since founding in 1970, E&A has remained strong and committed to providing responsive, high quality service to clients. For over 45 years, our success is a testimony to the expertise of our engineers, geologists, scientists, technicians, drillers, and administrative professionals. E&A's integrated engineering services – Geotechnical, Construction Materials Testing, Construction Engineering and Inspection, and Environmental Engineering – represent balanced divisions that support the land procurement and development process from the time a site is first being considered for potential development through project completion and onto project maintenance. E&A offers clients:

- One of the largest fleets of certified drill rigs in the southeast
- An AASHTO Accredited and CCRL Certified laboratory providing testing of soil, concrete, aggregate, hot mix asphalt, and bituminous materials
- Laboratory personnel who are well-trained to efficiently process specimens in a timely, accurate manner and share test results electronically
- A staff of more than 80 engineers, engineering interns, scientists, geologists, technicians, inspectors, drillers and administrative professionals

E&A is a wholly-owned subsidiary of Engineering Consulting Services, Ltd. (ECS) and a member of the ECS Group of Companies. With over 1,300 employees, ECS has grown to more than 50 offices and testing facilities spread across the Mid-Atlantic, Southern, and Midwestern states. ECS has three Florida offices in Orlando, Tampa, and West Palm Beach. ECS is currently ranked #86 in *Engineering News Record's* (ENR) Top 500 Design Firms (April 2015), and #196 in ENR's Top 200 Environmental Firms (August 2014).

### Key Staff

#### David Spangler, PE | 18 years of experience

David has managed hundreds of geotechnical investigations throughout Florida and the Southeast for proposed residential and commercial properties. He has also managed and performed Phase I and Phase II Environmental Site Assessments and throughout Florida and the Southeast for proposed residential and commercial properties. Additionally, David has performed and managed several construction materials testing projects. Key projects include:

- Hartley Road Improvements, Duval County, FL
- Shindler Road Improvements, Duval County, FL
- SR 23 Over Plantation Oaks Blvd., Clay County, FL

## SUBCONSULTANT

### **Carter Environmental | Environmental Permitting and Wetlands**

7 Waldo Street | St. Augustine, FL 32084

Phone: 904.540.1786

www.careterenv.com



Carter Environmental Services, Inc., (CES), is committed to providing professional and efficient services to clients with natural resource needs. CES is a full service, family-owned company providing complete environmental consulting services from St. Augustine, Florida. CES has experienced staff members who have provided these services to clientele for over 16 years. Our range of expertise includes wetland delineation, county, state and federal environmental permitting, dock and bulkhead permitting, protected flora and fauna species surveys and permitting, mitigation, preliminary wetland assessments, GPS and GIS analysis. CES distinguishes itself from its competitors through the ability to provide clients with clearly presented business information and solutions needed to operate profitably and efficiently. In this way, CES truly provides responsive, value added service.

### **Key Staff**

#### **Ryan Carter | 20 years of experience**

Ryan is a natural resource professional who specializes in environmental permitting in Florida. His expertise includes environmental permitting with the state and federal governments, the identification of native flora and fauna, forest ecology and management, and wetland mitigation design and monitoring. His education in the management of Florida ecosystems coupled with experience in private consulting and experience with federal, state, and local governments make him an excellent scientist to manage or assist with any project. Key Projects:

- County Road 210, St. Johns County, FL
- St. Johns Marketplace, St. Johns County, FL
- St. Augustine Airport, St. Johns County, FL
- St. Johns Bluff Road Extension, Duval County, FL

#### **Allan Hooker | 34 years of experience**

Allan has a comprehensive knowledge of wetlands and wildlife ecology, water quality assessment/sampling, benthic sampling, and State and Federal natural resources permitting. He has extensive experience in wetland delineation and has managed hundreds of projects with up to \$700,000 budget and exceeding 7,000 acres in size. He has a vast knowledge in Federal Section 10/401/404 Clean Water Act, and Section 7 Endangered Species Act permitting. He is detail-oriented and able to identify priority tasks, and meet regulatory/client-driven project schedules, within budget.

## SUBCONSULTANT

### **DRMP | Surveying and SUE**

8001 Belfort Parkway, Suite 200 | Jacksonville, FL 32256

Phone: 904.641.0123 | Fax: 904.641.8858

www.drmp.com



DRMP, Inc. has been in business since 1977 as a multi-discipline firm serving clients in the public, private and industrial sectors in the development of infrastructure for the community-at-large. DRMP's Surveying and Mapping Division has provided services to a large list of valued clients since our inception. Our Survey staff yields one of the largest survey capabilities in Florida. We are comprised of 13 Florida registered professionals, 11 survey technicians, and 20 field crews.

### **Key Staff**

#### **Glenn Lusink, PSM | 31 years of experience**

Glenn's experience with surveying and mapping includes producing and managing projects for transportation infrastructure (limited access and highway design), hospitality (theme parks and resorts) and continuing services contracts. During his career span, he has served in both the field and office providing him with a strong knowledge of field and office standards, which is essential to quality assurance/quality control of survey deliverables. Key Projects:

- SR 5/US 1 (CR 210 Interchange), St. Johns County, FL
- King Street, St. Johns County, FL
- CR 305 Extension, St. Johns County, FL

#### **Ryan Grab, CST II | 17 years of experience**

Ryan serves as SUE Field Crew Supervisor and Survey Crew Chief/Survey Technician with DRMP's Subsurface Utility Engineering (SUE) Division. His responsibilities include the coordination and supervision of SUE and Survey crews, project planning, utility coordination, and preparation of deliverables. Ryan's technical experience includes subsurface utility designation (CI/ASCE 38-02 QL-B) and location (CI/ASCE 38-02 QL-A) for large right-of-way projects and smaller sites, and obtaining survey data for the various types of surveys. Key projects:

- King Street, St. Johns County, FL
- I-95 Widening from St. Johns/Duval County Line to I-295, Duval County, FL
- Palm Coast Parkway Widening, Flagler County, FL

## Subconsultant

### GameSim | Visualization

12000 Research Parkway, Suite 436 | Orlando, FL 32826

Phone: 407.688.0587

www.gamesim.com



GameSim will assist in public involvement efforts by providing visualization of the completed CR 210 widening. GameSim products and services target the needs of the entertainment, modeling & simulation, and geospatial industries. GameSim engineers, designers, and artists maintain a customer-centric focus throughout the entire project lifecycle. Within the video game industry, GameSim can provide full game development services to publishers or work as a co-developer for other studios. Additionally, GameSim self-publishes products, bringing games directly to players. GameSim's geospatial terrain tool, Conform, is the fastest product on the market for importing and fusing geospatial datasets to produce high-quality visualizations of synthetic environments. Conform is used for military simulation, entertainment, urban planning, virtual worlds, and crisis management. Within the modeling and simulation industry, GameSim primes contracts with the government, as well as subcontracting to partner companies.

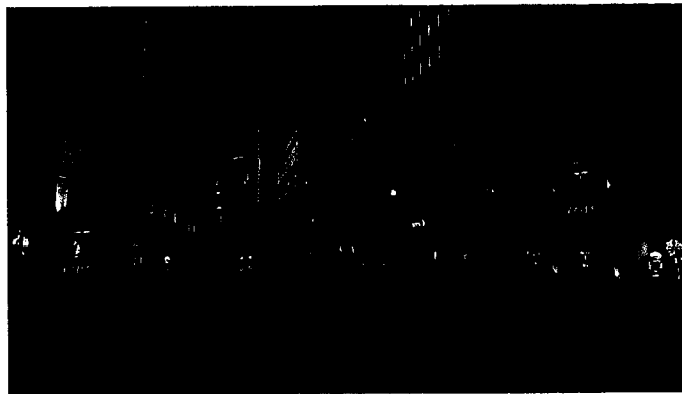

Computer Simulation

## Key Staff

### Alex McDaniel | 20 years of experience

Mr. McDaniel started his career at Walt Disney Feature Animation working on such films as *Hunchback of Notre Dame*, *Mulan*, and *Tarzan*. He made the transition from film into simulation working at Electronic Arts on titles such as the Madden, NCAA, NFL Tour, Head Coach, and PGA franchises. Additionally, Mr. McDaniel maintains a robust freelance career working with such companies as Sony, ILM, Wizards of the Coast and Disney Ideas among others. Key projects:

- Character Animator on feature film *8 Crazy Nights* RFX; Character Animator CG feature film *Action Man* ILM / Darkhorse; Cover Illustrations on Star Wars redemption series; Wizards of the Coast
- Madden 10, Madden 09, Madden 08, Madden 06 -Character Animator; NCAA 11, NCAA 10, NCAA 09, NCAA 08 -Character Animator; NFL Tour -Character Animator; Head Coach-Character Animator
- *Hunchback of Notre Dame* - In-between and breakdown CU Animator; *Mulan* - CU Key Animator; *Tarzan* - CU Key Animator

## Subconsultant

### **POND | Landscape Architect**

10199 Southside Boulevard, Suite 103 | Jacksonville, FL 32256

Phone: 904.543.0400

www.pondco.com



Pond was originally founded in 1965 as Armour & Associates and built a solid reputation as Armour, Cape & Pond. In 1998, the firm changed its name to Pond & Company as a reflection of the exponential growth of services and people since the doors opened in 1965. Pond's staff of 350+ professionals provides a deep bench of experience and the capabilities to offer personalized solutions to help clients manage projects from concept to completion – and everything in between – with confidence and clarity.

## Key Staff

### **Allan Iosue, RLA, LEED AP BD+C | 18 years of experience**

Mr. Iosue has over 18 years of experience in Landscape Architecture, Planning, Project Management and Transportation. Currently he manages the Transportation and Community Development practice in Florida and serves as Project Manager on a number of FDOT projects. He is a member of the Jacksonville Chamber's JAX Alliance Transportation Committee, Board member of the Transportation and Logistics Council Jacksonville Chamber of Commerce, USGBC, ASHE, FICE and the current Chair for the Context Sensitive Streets Standards Committee for the City of Jacksonville. Allan has a strong focus on urban and transportation projects in regards to Urban Planning, Landscape Architecture and Complete Streets, and continues to implement innovative solutions such as revious tree wells, bio-swales, native plantings and pedestrian gathering spaces. Key Projects:

- SR 200 Landscape, Nassau County, FL
- SR 202 (Southside Boulevard), Duval County, FL
- US 17/SR 5 (Main Street), Jacksonville, FL

## Corporate Licenses

**State of Florida  
Department of State**

I certify from the records of this office that ARCADIS U.S., INC. is a Delaware corporation authorized to transact business in the State of Florida, qualified on February 26, 1998.

The document number of this corporation is F98000001104.

I further certify that said corporation has paid all fees due this office through December 31, 2014, that its most recent annual report/uniform business report was filed on May 1, 2014, and its status is active.

I further certify that said corporation has not filed a Certificate of Withdrawal.

*Given under my hand and the  
Great Seal of the State of Florida  
at Tallahassee, the Capital, this  
the Twenty-ninth day of January,  
2015*



*Ken Dietman*  
**Secretary of State**

Authentication ID: CU9844603768

To authenticate this certificate, visit the following site, enter this ID, and then follow the instructions displayed.

<https://efile.sunbiz.org/certauthver.html>

**2015-2016 BUSINESS TAX RECEIPT**

**MICHAEL CORRIGAN, DUVAL COUNTY TAX COLLECTOR**  
231 E. FOREYTH STREET, SUITE 130, JACKSONVILLE, FL 32202-5170  
Phone: (904) 830-1618, ext 6013, Fax: (904) 830-1432  
Website: www.mdc.net Email: businesstax@dcf.net

Note - A penalty is imposed for failure to keep this receipt exhibited conspicuously at your place of business. This business tax receipt is furnished pursuant to Municipal Ordinance Code, Chapters 770-772, for the period October 1, 2015 through September 30, 2016.

**ARCADIS US INC**  
ATTN: KIM BATTLE@  
PO BOX 66  
SYRACUSE, NY 13214

**ACCOUNT NUMBER:** 45160  
**LOCATION ADDRESS:** 1650 PRUDENTIAL DR STE 400  
JACKSONVILLE, FL 32207

**DESCRIPTION:** PUBLIC SERVICE OR REPAIR, NOT SPEC

<b>COUNTY RECEIPT DESC:</b>	PUBLIC SERVICE OR REPAIR, NOT SPEC	<b>COUNTY TAX:</b>	50.00
<b>MUNICIPAL RECEIPT DESC:</b>	MC 772.326-15	<b>MUNICIPAL TAX:</b>	81.25
		<b>TOTAL TAX PAID:</b>	131.25

VALID UNTIL September 30, 2016

**\*\*\*ATTENTION\*\*\***  
THIS RECEIPT IS FOR BUSINESS TAX RECEIPT ONLY.  
CERTAIN BUSINESSES MAY REQUIRE ADDITIONAL STATE LICENSING.

This is a business tax receipt only. It does not permit the receipt holder to violate any existing regulatory or zoning laws of the County or City. It does not exempt the receipt holder from any other license or permit required by law. This is not a certification of the receipt holder's qualifications.

*Michael Corrigan*  
TAX COLLECTOR  
THIS BECOMES A RECEIPT AFTER VALIDATION.  
PAID-5505096.0011-0011 WEB 08/25/2015 131.25

**State of Florida**  
Board of Professional Engineers

Attests that  
**ARCADIS U.S., Inc.**





**FBPE**  
FLORIDA BOARD OF  
PROFESSIONAL ENGINEERS

is authorized under the provisions of Section 471.01, Florida Statutes, to offer engineering services to the public through a Professional Engineer, duly licensed under Chapter 471, Florida Statutes.



Expiration: 2/28/2017  
Audit No: 228201702877

CA Lic. No:  
7917

### Professional Licenses

**State of Florida**  
Board of Professional Engineers

Attests that  
**Walter John Nemecek III, P.E.**





Is licensed as a Professional Engineer, Chapter 471, Florida Statutes  
Expiration: 2/28/2017  
Audit No: 228201727495

P.E. Lic. No:  
58122

**State of Florida**  
Board of Professional Engineers

Attests that  
**Eric Howerton, P.E.**





Is licensed as a Professional Engineer, Chapter 471, Florida Statutes  
Expiration: 2/28/2017  
Audit No: 228201725536

P.E. Lic. No:  
43992

**State of Florida**  
Board of Professional Engineers

Attests that  
**Gregory Sowell Jr., P.E.**





Is licensed as a Professional Engineer, Chapter 471, Florida Statutes  
Expiration: 2/28/2017  
Audit No: 228201713443

P.E. Lic. No:  
58769

### Professional Licenses

**State of Florida**  
 Board of Professional Engineers

GREAT SEAL OF THE STATE OF FLORIDA  
 Adopts that  
**Roman Inigo Blanco, P.E.**





Is licensed as a Professional Engineer, Chapter 471, Florida Statutes  
 Expiration: 2/28/2017  
 Audit No: 228201727992

P.E. Lic. No:  
60806

**State of Florida**  
 Board of Professional Engineers

GREAT SEAL OF THE STATE OF FLORIDA  
 Adopts that  
**Christian Joseph Cyle, P.E.**





Is licensed as a Professional Engineer, Chapter 471, Florida Statutes  
 Expiration: 2/28/2017  
 Audit No: 228201716587

P.E. Lic. No:  
69159

**State of Florida**  
 Board of Professional Engineers

GREAT SEAL OF THE STATE OF FLORIDA  
 Adopts that  
**Cliff Davidson Capps, P.E.**





Is licensed as a Professional Engineer, Chapter 471, Florida Statutes  
 Expiration: 2/28/2017  
 Audit No: 228201733571

P.E. Lic. No:  
79346

### Professional Licenses

**State of Florida**  
Board of Professional Engineers



Attests that  
**Go P.E.**

Is licensed as a Professional Engineer, Chapter 471, Florida Statutes  
Expiration: 2/28/2017  
Audit No: 228201731206



**FBPE**  
FLORIDA BOARD OF  
PROFESSIONAL ENGINEERS  
P.E. Lic. No:  
76395

**State of Florida**  
Board of Professional Engineers



Attests that  
**Conzalez P.E.**

Is licensed as a Professional Engineer, Chapter 471, Florida Statutes  
Expiration: 2/28/2017  
Audit No: 228201717971



**FBPE**  
FLORIDA BOARD OF  
PROFESSIONAL ENGINEERS  
P.E. Lic. No:  
40720

**State of Florida**  
Board of Professional Engineers



Attests that  
**Satyajay Kolluru P.E.**

Is licensed as a Professional Engineer, Chapter 471, Florida Statutes  
Expiration: 2/28/2017  
Audit No: 228201730832





**FBPE**  
FLORIDA BOARD OF  
PROFESSIONAL ENGINEERS  
P.E. Lic. No:  
74459

Professional Licenses

**State of Florida**  
 Board of Professional Engineers

Attests that  
**Daniel Thomas Maxey, P.E.**





Is licensed as a Professional Engineer, Chapter 471, Florida Statutes  
 Expiration: 2/28/2017  
 Audit No: 228201724995

P.E. Lic. No:  
38342

**State of Florida**  
 Board of Professional Engineers

Attests that  
**Joas de Nijven, P.E.**





Is licensed as a Professional Engineer, Chapter 471, Florida Statutes  
 Expiration: 2/28/2017  
 Audit No: 228201728195

P.E. Lic. No:  
61791

**State of Florida**  
 Board of Professional Engineers

Attests that  
**Andrea Catherine Ruane, P.E.**





Is licensed as a Professional Engineer, Chapter 471, Florida Statutes  
 Expiration: 2/28/2017  
 Audit No: 228201733645

P.E. Lic. No:  
79420

## Professional Licenses

**State of Florida**  
Board of Professional Engineers



Charles Tech Wells, P.E.

Is licensed as a Professional Engineer under Chapter 471, Florida Statutes  
Expiration: 2/28/2017  
Audit No: 228201728793



**FBPE**  
FLORIDA BOARD OF  
PROFESSIONAL ENGINEERS  
P.E. Lic. No:  
64690

# RELATED EXPERIENCE



## 4. RELATED EXPERIENCE

### New World Avenue Extension

City of Jacksonville, Florida

John Pappas, PE, 904.255.8786

\$1.0 M Design | \$14 M Construction | Completed: 2008

**Relevance:** Two- to four-lane widening | Designed to urban roadway | Meets FDOT/AASHTO standards | Permitted through SJRWMD | Includes sidewalks and bike lanes

This project constructed a four-lane, urban, divided roadway, sidewalks, and bike lanes from Fingerlake Street to SR 23. We performed the design of roadway, intersections, and lighting, as well as the design and permitting of the stormwater treatment, collection, and outfall systems that tie into the Cecil Commerce Center drainage scheme.

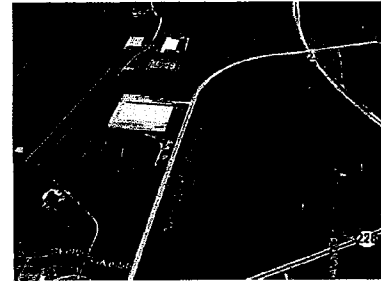

### SR 21 (Blanding Boulevard) Widening

FDOT D2; Clay County, Florida

James (Jamie) Driggers, Jr., 386.758.3722

\$1.2 M Design | \$15.9 M Construction | Completed: Under construction

**Relevance:** Two- to four-lane widening | Designed to urban roadway | Meets FDOT/AASHTO standards | Permitted through SJRWMD | Includes sidewalks and bike lanes | Same design team

The project was 1.5 miles of four-lane, rural, divided highway being widened to a six-lane urban roadway. We provided drainage design, geometric design, permitting, lighting, ITS, MOT, structural and quality control measures with the remainder of the project tasks completed by District 2 in-house design staff. We functioned as a critical component of a team working closely with the District Design Engineer and his staff. This team approach with the FDOT allowed the FDOT to be flexible in scope and to accelerate the schedule without sacrificing quality. Our innovations saved approximately \$12 M in construction costs.



### SR 200 (A1A) Widening

FDOT D2; Nassau County, Florida

Will Lyons, PE, 604.360.5574

\$1.5 M Design/\$26 M Construction | Completed: 2011

**Relevance:** Two- to four-lane widening | Designed to urban roadway | Meets FDOT/AASHTO Standards | Permitted through SJRWMD

This project involved widening from two to four lanes and included the replacement of two bridge structures. The facility is a Rural Principal Arterial and is part of the Strategic Intermodal System (SIS). Roadway design included a four-lane, urban typical section to the south (2.25 miles) and a four-lane, rural typical section to the north (3.8 miles). The right-of-way was acquired and designated as controlled access. The roadway and offsite runoff drained either directly to adjacent lands or into parallel roadside swales that conveyed the runoff to the nearest cross drain outfall, where it then left the project area through lateral ditches. The existing roadway did not provide treatment or attenuation for stormwater runoff.

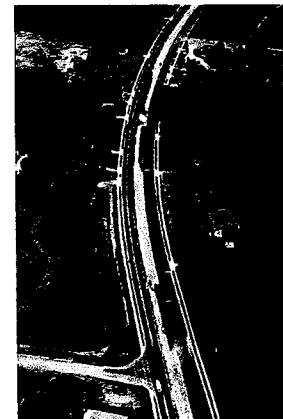

# PROJECT APPROACH & INNOVATION

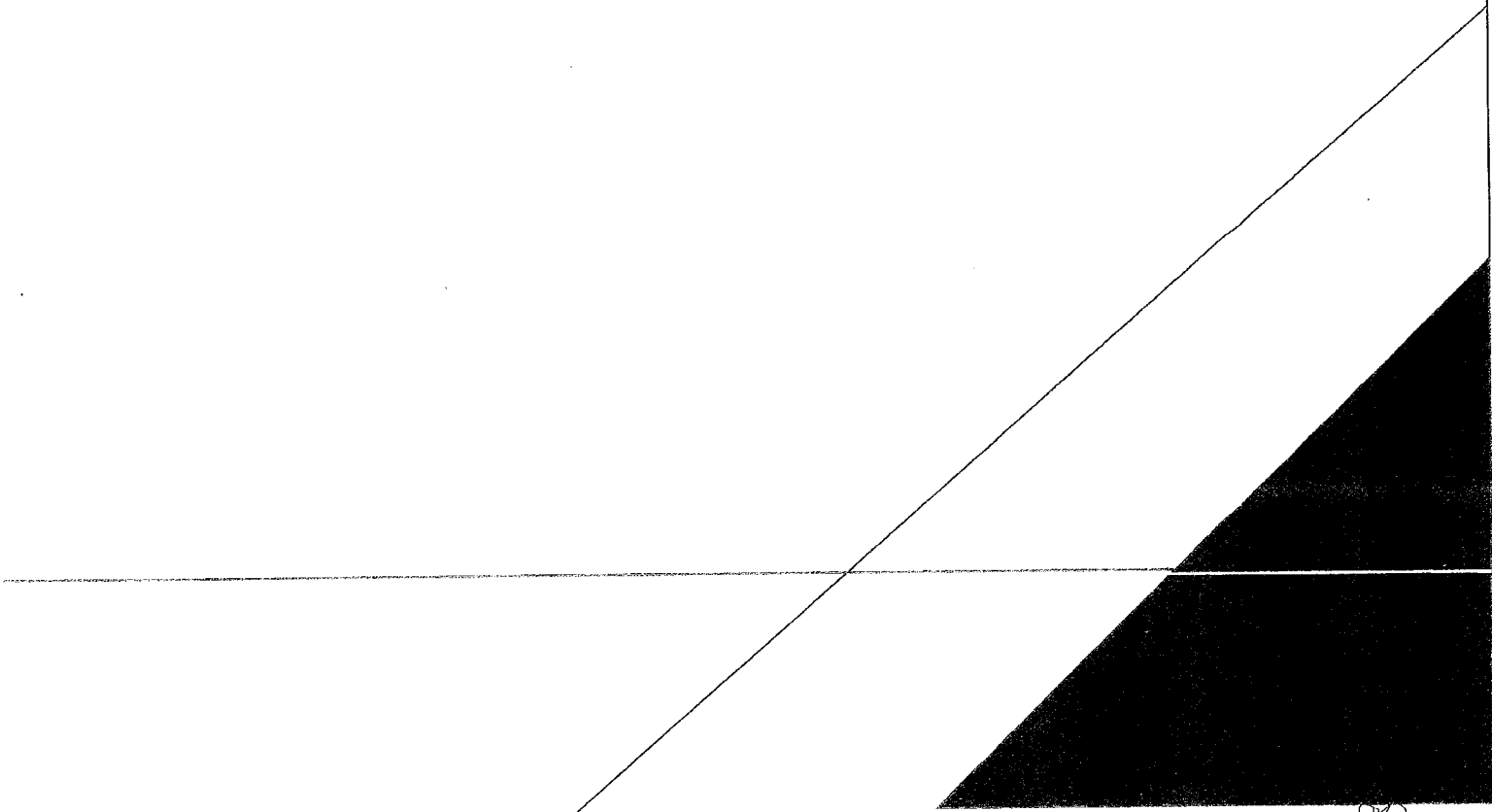

## 5. PROJECT APPROACH AND INNOVATION

 This icon denotes an Arcadis innovation

### Roadway

The typical section is a two-lane rural section from CR 223 to a four-lane urban section approximately one quarter mile before Cimarrone Blvd. with sidewalks along the urban section and the east end of the rural section. CR 223 and Cimarrone Blvd. intersections are signalized, while the South Hampton Club Way (west) and Shearwater Parkway intersections are unsignalized. The existing right-of-way (ROW) varies between 100' to 150' throughout.

 The proposed typical section includes a four-lane roadway with bike lanes that can be expanded to a six-lane section in the future without constructing new sidewalks, working in the median, or impacting the new pavement. As the ROW is slightly narrower than the standard County six-lane urban typical, we recommend the ultimate roadway section be modified to a median width of 30'

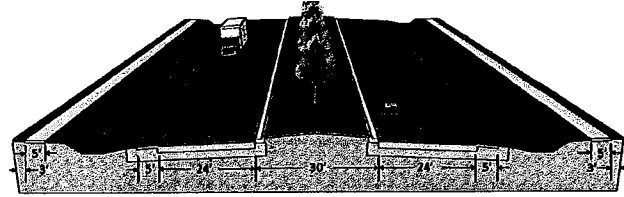

Four-lane typical section with 0.3% minimum profile slope for future six-lane urban widening.

between the inside edges of pavement similar to the existing CR 210 to the east. By constructing the four interior lanes with rural outside shoulders and collection system, the trunk line for the six-lane configuration can be easily installed now or in the future, and impacts to traffic are minimized when the additional lanes are constructed. However, we have the option of a full urban four-lane section if you would like to invest an additional \$1.5 M in curb and piping during this project.

 According to the St. Johns County Property Appraiser website, the existing ROW changes from 125' at Cimarrone Blvd. to 100' near Wetherby Ln. It is 150' adjacent to Stone Creek and ranges between 100' and 110' to CR 223. The intended corridor has a consistent width of 150'. However, special consideration should be given to the ROW shift at the east end of Stone Creek. Even though 150' is available through this section, construction space is offset on opposite sides of the existing roadway. We propose aligning the roadway so a corner clip is only necessary on the north side from a single property owner. Our 3D model will verify the precise footprint of the proposed road.

Due to the residential surroundings, the roadway will be designed for 45 mph. The pavement design follows County standards for a six-lane roadway, consisting of 1.5" SP-9.5, 3" SP-12.5, 12" limerock, and 12" stabilized subgrade. Depending on the geotechnical exploration, the roadway profile will likely be slightly higher than its current elevation and we may use black base if groundwater is too high. The existing Cimarrone Blvd. intersection will be evaluated for potential improvements. Intersection improvements are included at the South Hampton Club Way (west), Shearwater Pkwy., and CR 223 intersections.

### Drainage

We evaluate permitting the ponds for the six-lane build-out to eliminate future ROW purchases and revising the permit. The new geometry conveys stormwater to available pond site locations, provides clearance for CD extensions, and provides HGL clearance for Design High Water stages in the ponds. Major crossings are designed to accommodate the future six-lane widening: including just east of Stone Creek, near the 5th Hole in Cimarrone, the Bridge over Trout Creek, and under CR 210 at the intersection with Greenbriar. Collection system is rural, however we will design the profile with a minimum of 0.3% slope and install crossing pipes at low points to eliminate open cutting the asphalt in the future.

We evaluated multiple approaches to provide you with options to reduce costs, maintenance, legal fees, negotiations, and permit modifications. This thorough analysis allows the County to tailor the ROW purchases to the public need, avoid unwilling sellers, and adjust to the changing market. Once the geometry is established our team will propose a drainage solution best fitting the County’s needs for schedule and cost. In pre-proposal meetings with County staff the preference was for pond ROW purchases to be combined with the purchase of roadway ROW. However, the RFQ suggests evaluating joint-use ponds prior to new ROW purchases. The balance of these needs is reflected in the three design scenarios we evaluated.

*We evaluated three innovative drainage scenarios including joint-use ponds, comingling offsite runoff, and nutrient removal in offsite regional ponds. The geometry of the roadway and existing cross drains divides the project into five drainage basins. A conventional approach requires five pond parcels; however, we propose a more economical solution.*

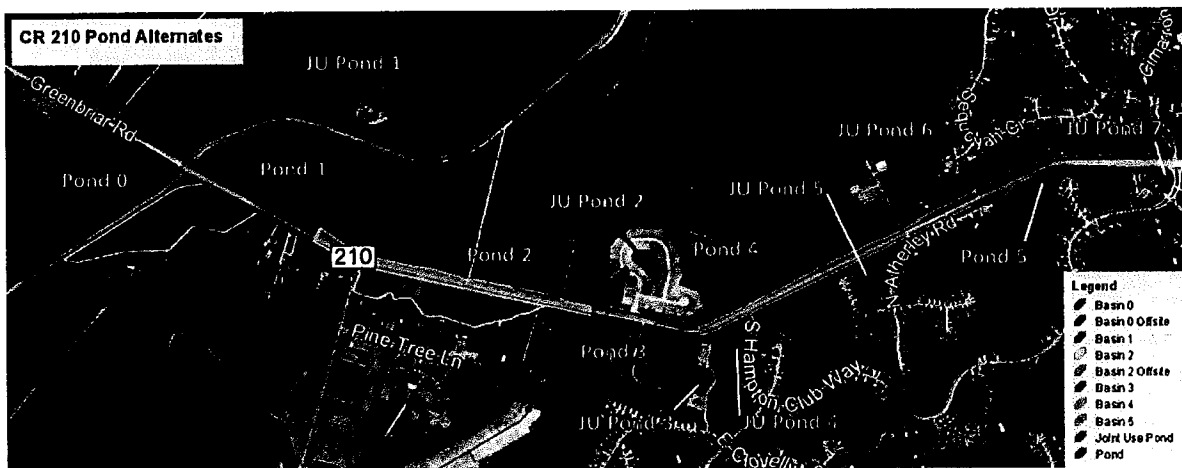

CR 210 Pond Alternatives

**Scenario 1 – Joint Use Ponds:** We evaluated seven existing ponds for joint-use opportunities. Due to location and available capacity, treatment involves as many as five joint-use pond locations. We investigated the following permits: 99377 CR 223, 140461 Stone Creek, 21597 South Hampton, 92509 Shearwater, and 21315 Cimarrone. All opportunities require negotiations, easement purchases, and permit modifications. The available locations do not provide treatment for Basin 2. Another pond location is needed for direct or compensating treatment.

**Scenario 2 – Comingling:** We utilized Pond 2 and identified a new pond (Pond 0) near Basin 1 to compensate for all five basins. Similar to Pond 2, which compensates for Basin 2-4, Pond 0 treats onsite roadway in Basin 1 and existing roadway and offsite residential in Basin 0 to compensate for Basin 5.

**Scenario 3 – Regional Pond:** We identified a single pond location offsite in the Trout Creek Basin that would treat 108 acres of Weedman Farms to offset the untreated improvements along CR 210. This is the only pond necessary for purchase and could serve as a regional pond for surrounding future development.

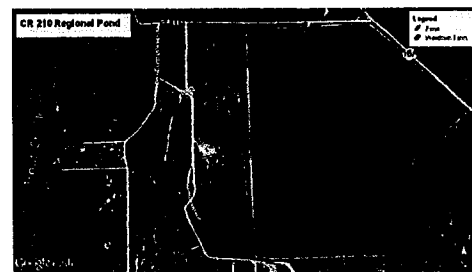

Scenario 3 - Regional Pond

**Permitting**

Before preparing the 60% plans, we hold a formal pre-application meeting with St. Johns River Water Management District (SJRWMD) using their standard form to vet alternative treatment methods in order to secure an Environmental Resource

Permit and a Nationwide Permit from US Army Corps of Engineers (USACE). We also lay the groundwork for permitting for the ultimate six-lane section while designing a four-lane section. Requirements from the pre-application meeting are incorporated into the 60% plans. After your review of the 60% plans, wetland impacts are evaluated and a mitigation plan is established for both the SJRWMD and the USACE, using St. Johns County credits at Turnbull Regional mitigation Area. Wetland impacts are assessed using the Uniform Mitigation Assessment Method (UMAM), then a permit application is submitted resulting in no RAIs.

### Legal Description and Maps

We develop ROW maps and legal descriptions for property acquisition after the 60% submittal. Maps can be finalized after the drainage design is permitted. Based on the ROW already donated or set aside by developers, we anticipate a 50' wide purchase from Helow Properties LTD along the north side from Greenbriar to Stone Creek and a purchase on the south of the 50' ROW set aside by South Hampton from Stone Creek to Cimarrone Blvd. We propose a corner clip purchased from Terrapointe LLC just east of Stone Creek to fit the alignment within the pinch point caused by the ROW purchases being on opposite sides of the existing ROW. With 3D design, we know how the proposed roadway and drainage fit in the ROW, thus reducing uncertainty and rework.

### Structural

The existing CR 210 Trout Creek Bridge (No. 784042) was built in 1981 and consists of prestressed slabs supported by concrete pile bents. The National Bridge Inventory rates the bridge at 28.5 tons which is less than desirable. We anticipate replacing this bridge due to the reconstruction of the road. A Bridge Hydraulics Report will be prepared to determine design flood elevations and scour potential. According to the inspection report, the creek bank at this location is beginning to slump and embankment protection has widespread minor damage.

We anticipate constructing dual structures at this location accommodating three lanes of traffic in each direction. Our design approach evaluates economical Florida I Beam (FIB) superstructures supported by prestressed concrete pile bents as well as a *new prestressed flat slab system known as the Florida Slab Beam (FSB) that can minimize profile elevation and environmental impacts.*

### Maintenance of Traffic

Maintenance of traffic consists of two major phases and two sub-phases. Because the additional ROW is on opposite sides of the existing road in different segments, this MOT plan has more phases than a typical four-lane widening to account for the crossover. MOT phasing is included in the Additional Information Section.

### Signing, Lighting and Pavement Markings

*Where possible, lighting, landscaping, and signs are located to avoid relocation or replacement in the future six-lane configuration. We include clear signing and lighting for bicycle lanes and pedestrian facilities.*

### Intersection Improvements and Traffic Signals

County Standard Specifications and preferences are augmented with special provisions as needed. New signals are galvanized steel mast arms with luminaires. *Although CR 210 is being widened to four lanes, all signal equipment, communication devices, conduit runs, and pull boxes are positioned to not require relocation when CR 210 is widened to six lanes.*

- Greenbriar Rd. and CR 223 require a complete signal redesign to accommodate the four-lane typical and the new approach (future CR 223) on the north side of the intersection.

- CR 210 and Shearwater Parkway warrant a new signal.
- A traffic signal warrant study is conducted for South Hampton Club Way (west).
- No impacts are anticipated for the existing signals at Cimarrone Blvd. We will evaluate adjustments for the six-lane typical as a bid alternate.

## Utility Coordination

Identified utilities include water, gas, buried fiber optic, overhead electric distribution, overhead cable, overhead telephone, and overhead electric transmission (FPL and JEA). Our utility coordinator sends plans to all utility holders to review and draw approximate locations of existing and proposed facilities. We will meet with utility representatives to verify information and possible conflicts. *This process is enhanced by utilizing a 3D model of the drainage systems to identify potential utility conflicts.* Conflict locations are field-verified, after which we make certain utility owners know what needs to be relocated prior to construction. We anticipate most utility adjustments to be relocations near the ROW line.

## Initial Plans and 3D Design

**Initial Design and Permitting Phase:** *Arcadis will prepare 60% plans and 3D design using the latest OpenRoads Software and Microstation SS4.* Our plan in the initial stage is to perform the necessary design to permit the project, identify utility conflicts, and secure ROW by preparing the 3D design. In doing so, we will have a very accurate cost estimate and modifications are quick and easy to perform to investigate alternative designs.

3D design is more cost effective for construction since contractors can perform major construction activities using Machine Control equipment. This saves approximately 10% in construction costs over conventional plans. Construction is faster, the contractor does not need surveying, and accuracy is significantly improved with less waste for asphalt and earthwork.

Once we have submitted the 60% plans, we obtain the SJRWMD construction permit, finalize utility conflicts and relocation, and halt design efforts until adequate funding is secured for construction. This is the best use of design funding to make certain we do not need to redesign based on changing conditions or standards.

**Final Detailed Design, Bid Documents, and Construction Phase Support:** Once the local and regulatory design requirements have been incorporated into the 60% design, we add all necessary details for construction including specific construction details for structures and unique designs, pertinent regulatory details, signalization plans, erosion control plans, traffic control plans, mitigation plans, and signing and marking plans. Detailed bid documents and design specification are prepared for bidding. We remain available and place priority to providing plans clarification for the contractor during the construction phase.

## Public Involvement

To be successful, this CR 210 widening needs the support of the community. Our in-house public involvement staff has extensive experience in stakeholder engagement and consensus building. We work closely with you from the beginning to develop key messages and desired outcomes. Our tools include Facebook, Twitter, websites, and public meetings with interactive and real-time polling. *The interactive polling from Poll Everywhere* allows attendees, through the use of smart phones or provided laptops, to respond to pre-determined questions and share real time results with the public. **Walter Nemecek** and **Elizabeth Beam** lead the communication effort and develop a plan to use these tools and the target audience to develop a proactive approach. We have successfully used this process for clients across the country.

# QUALITY & SCHEDULE CONTROL

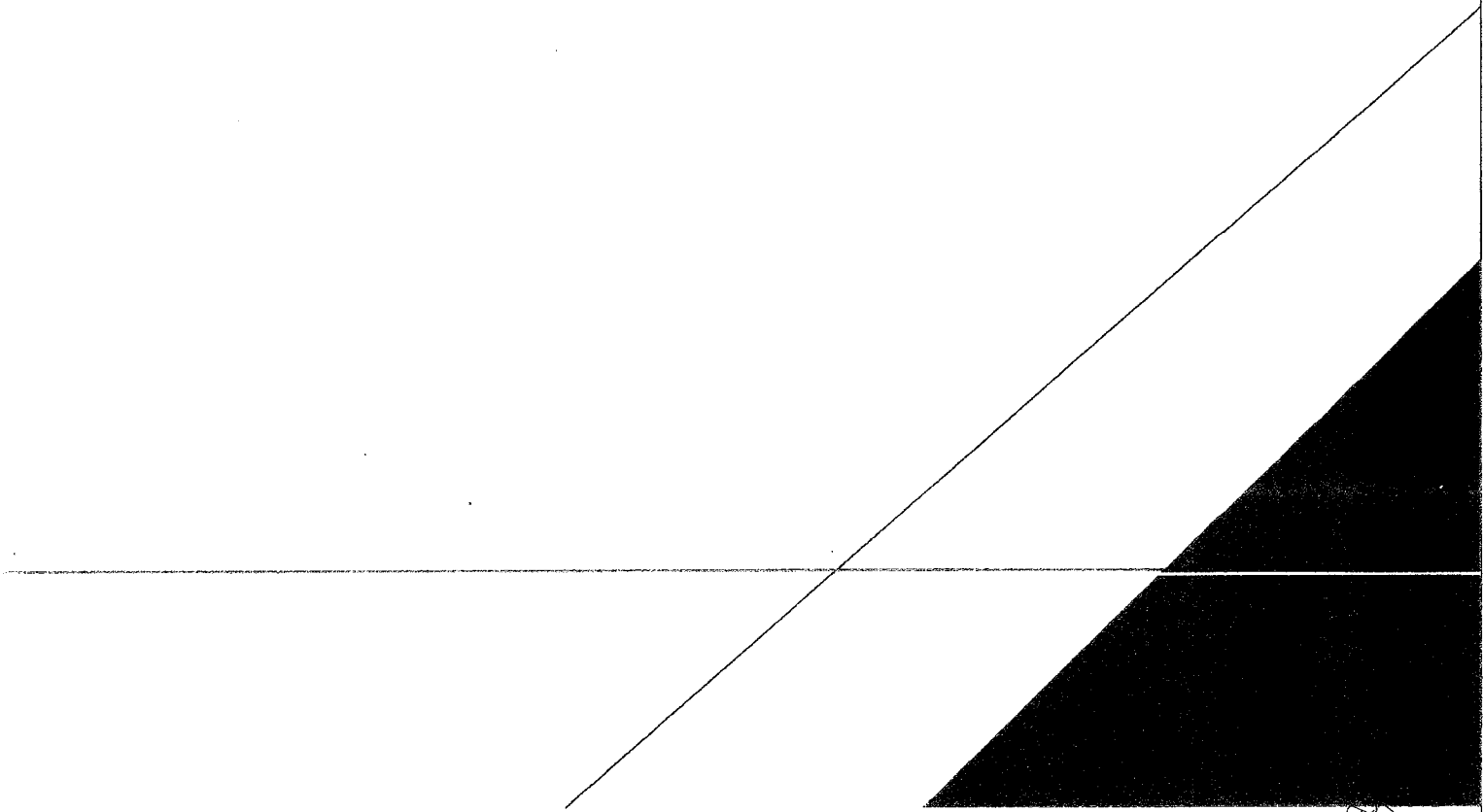

## 6. QUALITY AND SCHEDULE

### Project Management and Control

#### Quality Matters

Quality is the foundation of all our client offerings from start to finish. Our company-wide commitment to quality is instilled from the highest levels down. It begins at the planning stage well before any work is performed. All of our activities include a focus on quality in understanding your needs, project staffing, technical approach, and project implementation and management.

Our philosophy is proactive, and we actively follow our “Quality Matters” program to assure a quality design. Through this approach, staff can bridge office locations and come together as a sound team. With 19 years of experience, **Gary Sowell, PE, Jr.**, provides quality reviews on all roadway projects completed in Florida. This benefits you by:

- Fully understanding what you are asking for rather than assuming what you need
- Defining, developing and implementing solutions focused on the “right” problem
- Empowering our project and quality managers to immediately correct any actual or perceived shortcomings

All personnel have access to our Quality Management Manual and receive training and mentoring on their position, duties, and/or assignments. We employ a multi-faceted approach to managing project quality by developing and executing a Quality Control (QC) Plan including key review milestones. We define the Quality Assurance (QA) team and include technical experts from relevant discipline who are not involved in the daily activities of the project. The QC Plan includes the following:

**Project Goals:** At project kickoff, team members consider the criteria by which the final project is determined a success. We rank these criteria according to importance and measure alternatives according to their ability to satisfy project goals. At intermediate milestones, we review project goals and the team meets on an ongoing basis to determine if the goals are being met.

**Accurate and Updated Project Costs:** Estimates of probable construction costs are developed early in the project and used as part of the decision making process. We regularly update the estimated construction costs, thereby allowing you to monitor changes and make informed decisions when the need for scope changes occurs.

**Inter-discipline Reviews:** During design, inter-discipline reviews occur regularly. This cross-checking keeps all disciplines abreast of changes, thereby reducing errors and omissions on the

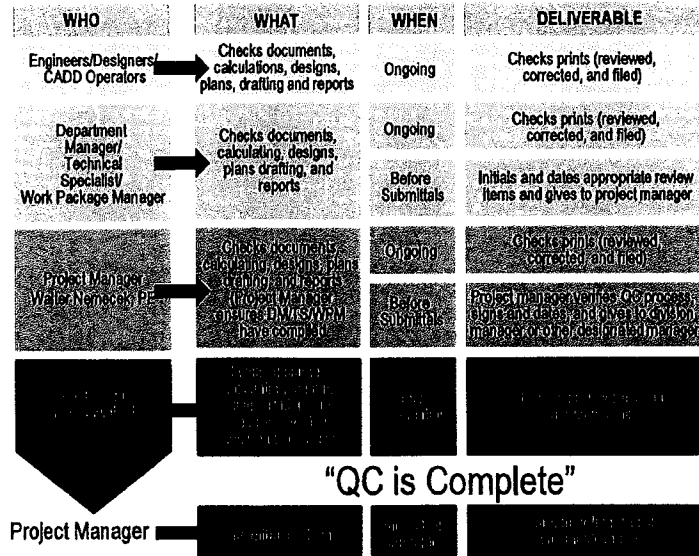

Arcadis adheres to a strict quality control process



final documents. A list of unresolved issues is accessible to all team members and regular meetings resolve issues.

**Coordination Check:** All construction drawings are reviewed for accuracy, neatness, uniformity, drafting standards, errors, omissions, consistency between disciplines, conflicts, physical interferences, dimensions, spelling, grammar, completeness, and conformance with project specifications. After all corrections are made, design staff back-check, date, and sign the drawings and specifications. The coordination check confirms designs and specifications are clear and consistent.

**Constructability Review:** A constructability review ensures the design can be built without extraordinary cost and unusual materials, construction techniques, or special equipment requirements are identified and justified. **Erik van Zanden** performs the review and verifies compliance, the comprehensive quality of the design drawings and specifications, and overall constructability. This review typically occurs at 30-, 60- and 90% stages. The 3-D model is a key component of the quality process including constructability verification.

### Ability to Meet Schedules in a Timely Manner

Arcadis considers conformance to the established project schedule and budget requirements to be fundamental to our successful project performance, and to maintaining client relationships according to our client-focused business model. Our experience has demonstrated that factors necessary for schedule and budget management include:

- A single point of contact for Arcadis: Project Manager, Walter Nemecek
- A project manager experienced with you and trained in the Arcadis Certified Project Management Program
- A complete scope well understood by all involved parties and staff
- A thorough project execution plan including labor-hour budgets by task and a project schedule with established milestone dates
- Periodic reviews of project execution against the plan by Arcadis senior management
- Frequent and effective communications between the County and the Arcadis project manager

We commit to meeting, or exceeding, time and budget requirements established with our clients. Our system of regular communication activities, such as kick-off meetings, team updates, and task/program reviews, provides a vehicle to adjust plans to execute schedule and budget requirements efficiently, as well as identify any issues early. The project manager reviews projects at a minimum once a month to monitor progress and make refinements and course corrections. The result of these efforts is better-faster-cheaper execution for the individual task and across the entire program.

### Project Schedule

The Arcadis project management process creates a flow resulting in a project schedule which prevents gaps in data acquisition, interpretation, and presentation, see the Additional Information Section. We use Microsoft Project to develop schedules and perform project tracking. Resources for work order assignments are allocated through coordination with business practice managers and department managers. The initial step identifies the specialized skills needed, and the project manager then coordinates these needs with the department and business practice managers. By planning each project and assessing the workload availability, we are able to allocate our resources to each project appropriately.

# ADDITIONAL INFORMATION

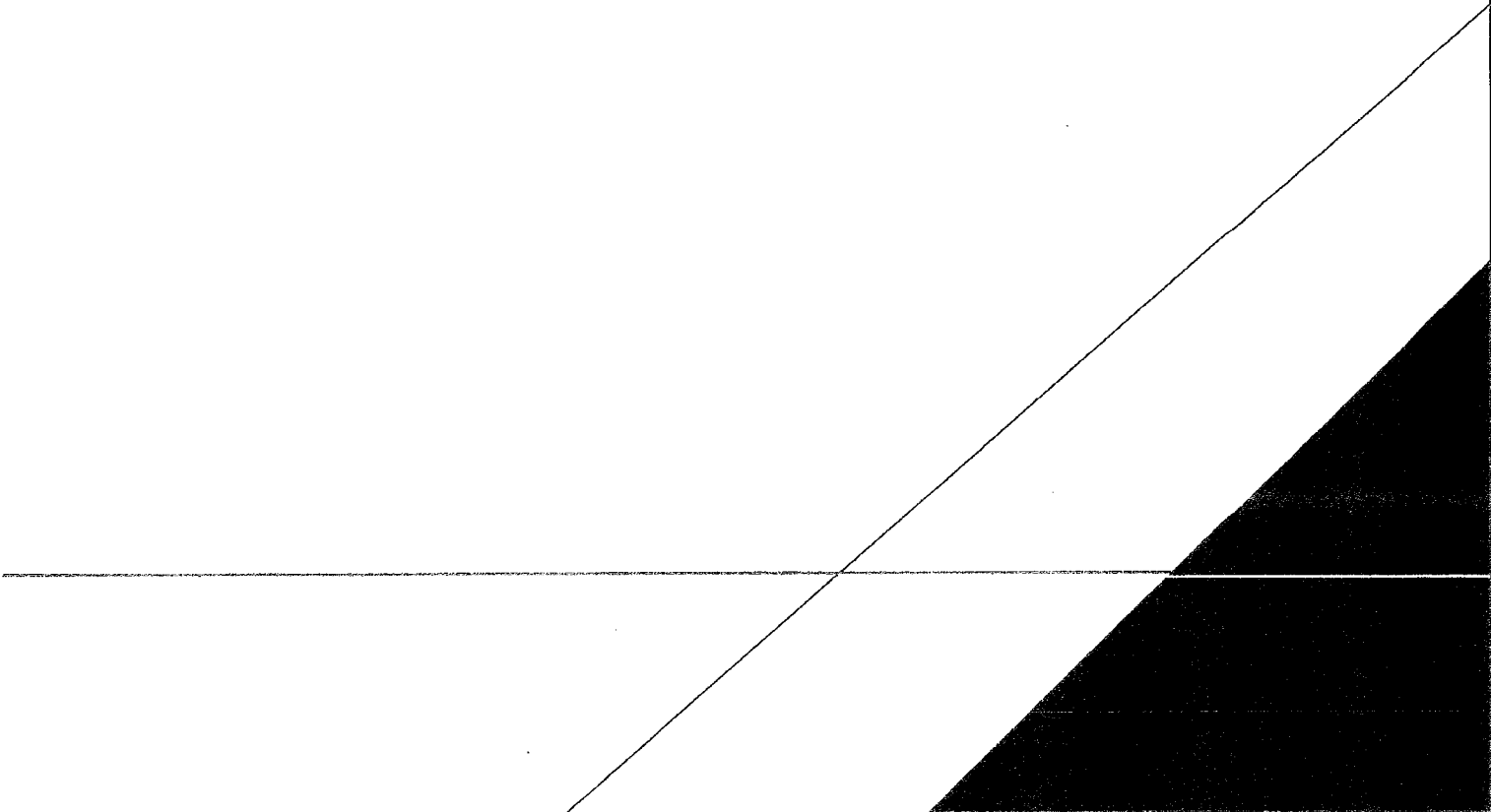

## 7. ADDITIONAL INFORMATION

### 3D Modeling

We implement the latest in cutting edge technology to evaluate constructability, estimate material quantities, and increase accuracy during construction. This is achieved by preparing a 3D model, both physical and electronic, of the entire project corridor. A 3D rendering can detect utility conflicts, verify bridge clearances, and uncover potential deficient geometric designs. Additionally, 3D models clearly communicate complex transportation solutions to stakeholders. We have extensive experience in the use of GEOPAK Corridor Modeler and most recently in the application of OpenRoads software to develop 3D designs. We are industry leaders in 3D renderings, flythrough videos, and visualization.

We recently applied this process to the FDOT SR 9B from I-95 to CR 2209 Design-Build in St. Johns County. Modeling the entire corridor in OpenRoads software allows the contractor to build the project with machine control technology directly from a computer. This resulted in a schedule savings of more than two months and \$5 M cost savings.



Model of SR 9B over Race Track Road

We have prepared a preliminary 3D model for CR 210 from existing LiDAR. The graphic below demonstrates the ability to cut cross sections at any point and adjust the profile dynamically to optimize earthwork.

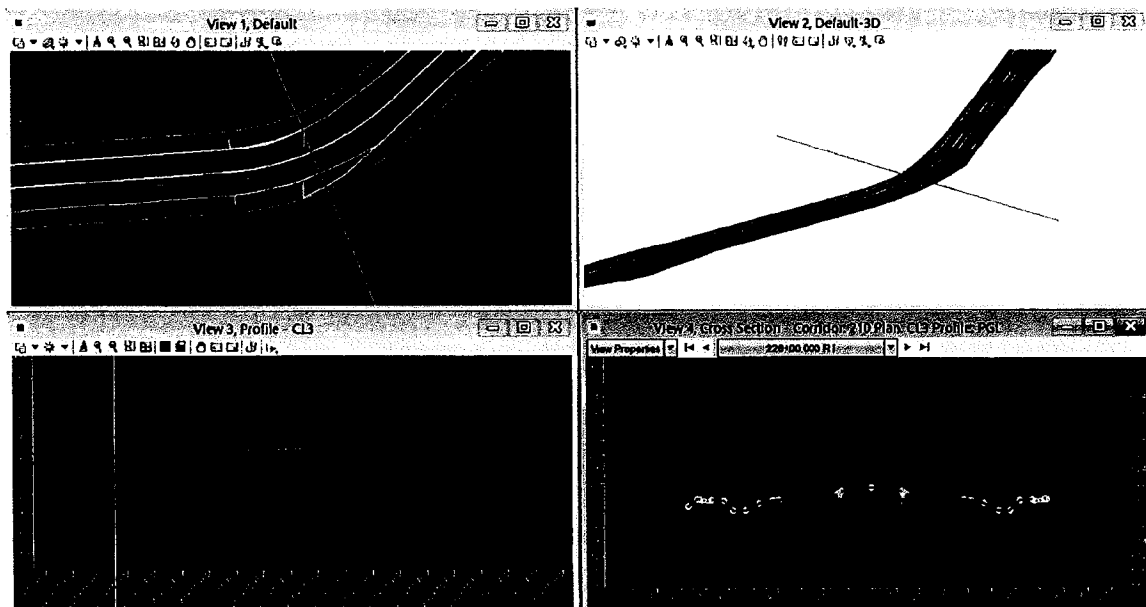

CR 210 preliminary 3D model in OpenRoads

### Cost Estimates

Arcadis performed a preliminary cost estimate for our proposed four-lane design and the total is \$16,400,000. This estimate does not include utility relocation or the option of trunkline installation throughout the corridor. The estimate for the six-lane section is \$24,000,000.

## 7. ADDITIONAL INFORMATION

### 3D Modeling

We implement the latest in cutting edge technology to evaluate constructability, estimate material quantities, and increase accuracy during construction. This is achieved by preparing a 3D model, both physical and electronic, of the entire project corridor. A 3D rendering can detect utility conflicts, verify bridge clearances, and uncover potential deficient geometric designs. Additionally, 3D models clearly communicate complex transportation solutions to stakeholders. We have extensive experience in the use of GEOPAK Corridor Modeler and most recently in the application of OpenRoads software to develop 3D designs. We are industry leaders in 3D renderings, flythrough videos, and visualization.

We recently applied this process to the FDOT SR 9B from I-95 to CR 2209 Design-Build in St. Johns County. Modeling the entire corridor in OpenRoads software allows the contractor to build the project with machine control technology directly from a computer. This resulted in a schedule savings of more than two months and \$5 M cost savings.

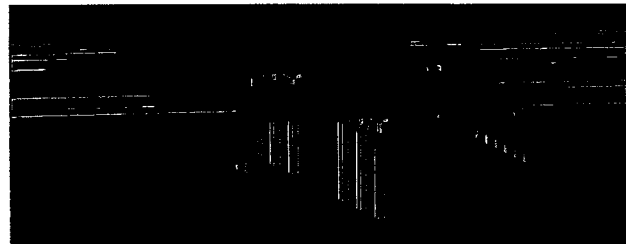

Model of SR 9B over Race Track Road

We have prepared a preliminary 3D model for CR 210 from existing LiDAR. The graphic below demonstrates the ability to cut cross sections at any point and adjust the profile dynamically to optimize earthwork.

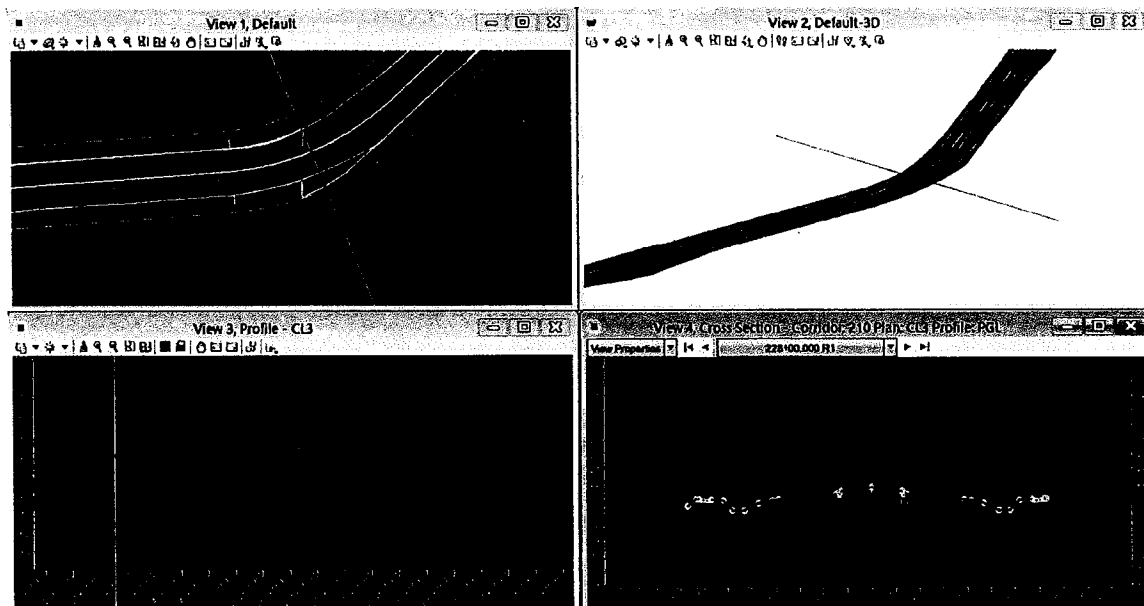

CR 210 preliminary 3D model in OpenRoads

### Cost Estimates

Arcadis performed a preliminary cost estimate for our proposed four-lane design and the total is \$16,400,000. This estimate does not include utility relocation or the option of trunkline installation throughout the corridor. The estimate for the six-lane section is \$24,000,000.

## MOT Typical Sections

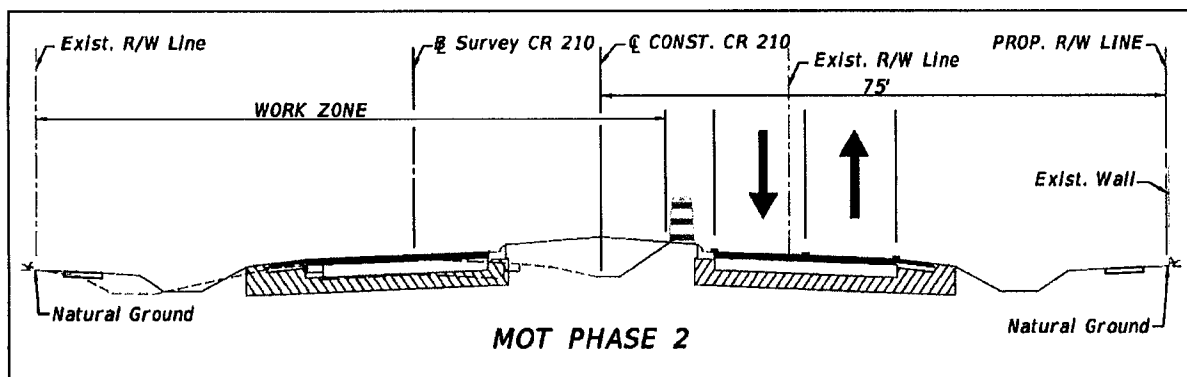
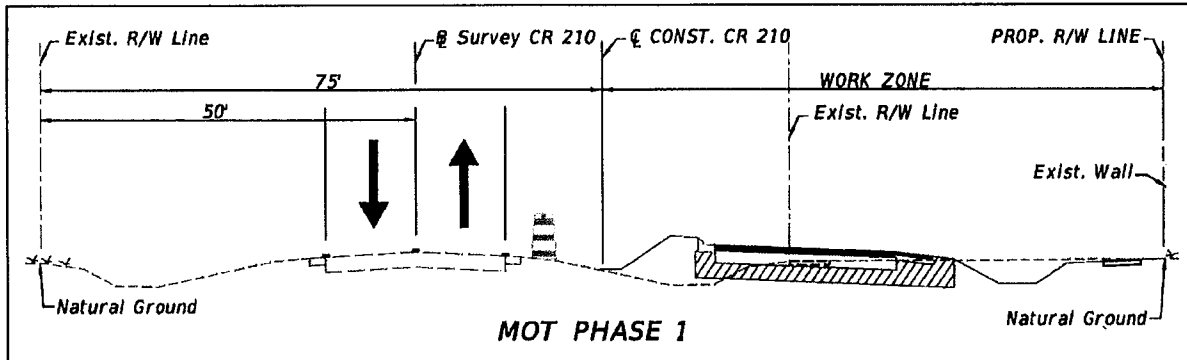

## References

Arcadis has performed exceptional roadway design services for St. Johns County and other agencies in Northeast Florida. Please contact the agency staff listed below for validation of our performance.

### Jeb Smith

District 2, Chair Commissioner  
St. Johns County  
500 San Sebastian View  
St. Augustine, FL 32084  
904.209.0302 | bcc2jsmith@sjcfl.us

### Darrell Locklear, PE

Assistant County Administrator  
St. Johns County  
4020 Lewis Speedway  
St. Augustine, FL 32085  
904.209.0540 | dlocklear@sjcfl.us

### James (Jim) M. Knight, PE

Urban Planning and Modal Administrator  
Florida Department of Transportation, D2  
2198 Edison Avenue  
Jacksonville, FL 32204  
904.360.5646 | james.knight@dot.state.fl.us

### James (Jamie) M. Driggers, Jr., PE

Program Management Engineer  
Florida Department of Transportation, D2  
1109 South Marion Street  
Lake City, FL 32025-5874  
386.758.3722 | james.driggersjr@dot.state.fl.us

### Vern Danforth, PE

CADD Applications Support  
Florida Department of Transportation  
Engineering/CADD Systems Office  
605 Suwanee Street, Mail Station 69  
Tallahassee, Florida 32399-0450  
850.414.4897 | vern.danforth@dot.state.fl.us

### John P. Pappas, PE

Deputy Director of Public Works  
City of Jacksonville  
214 N. Hogan Street, 10th Floor  
Jacksonville, FL 32202  
904.255.8786 | pappas@coj.net

# Project Highlights Map

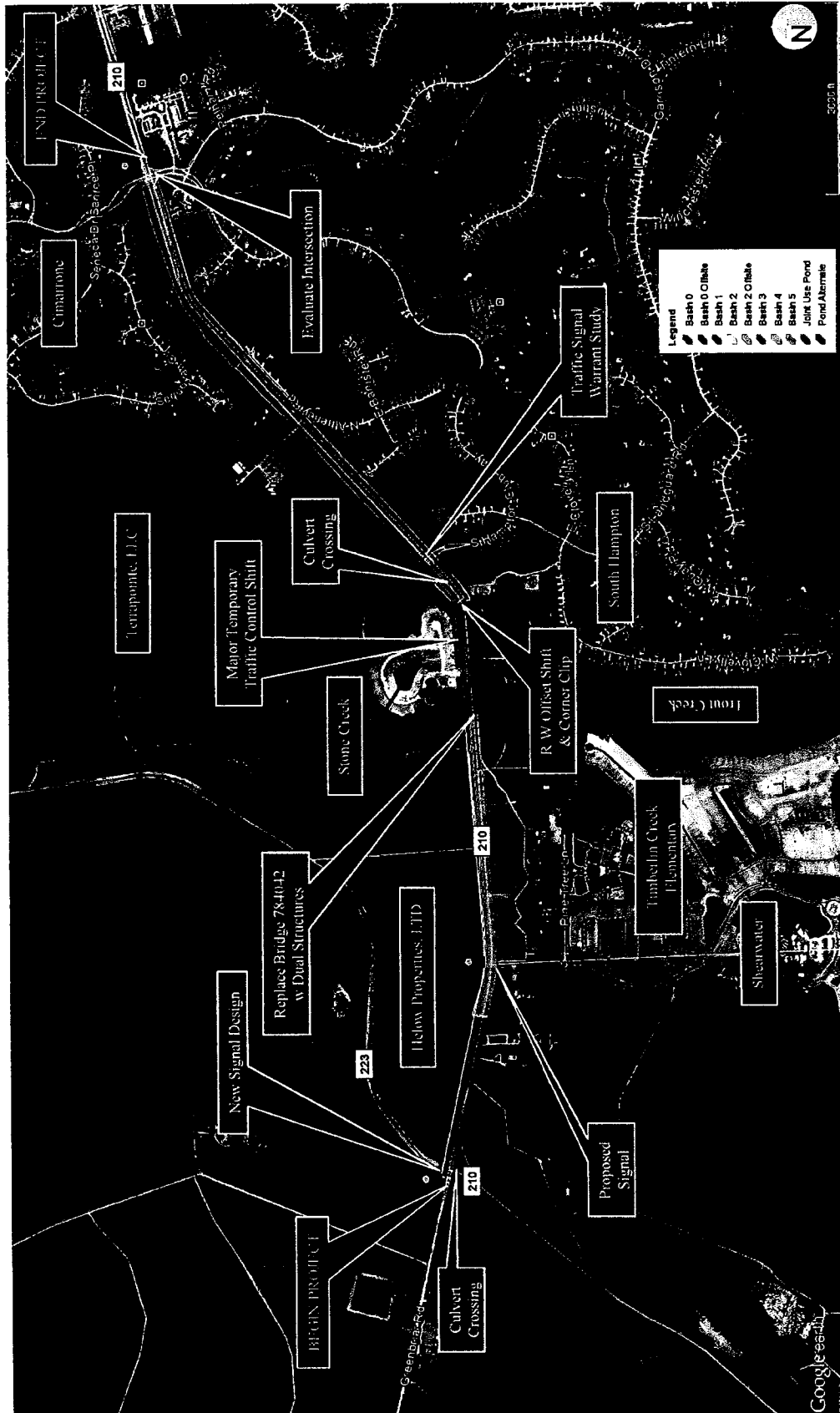

# Proposed Project Schedule

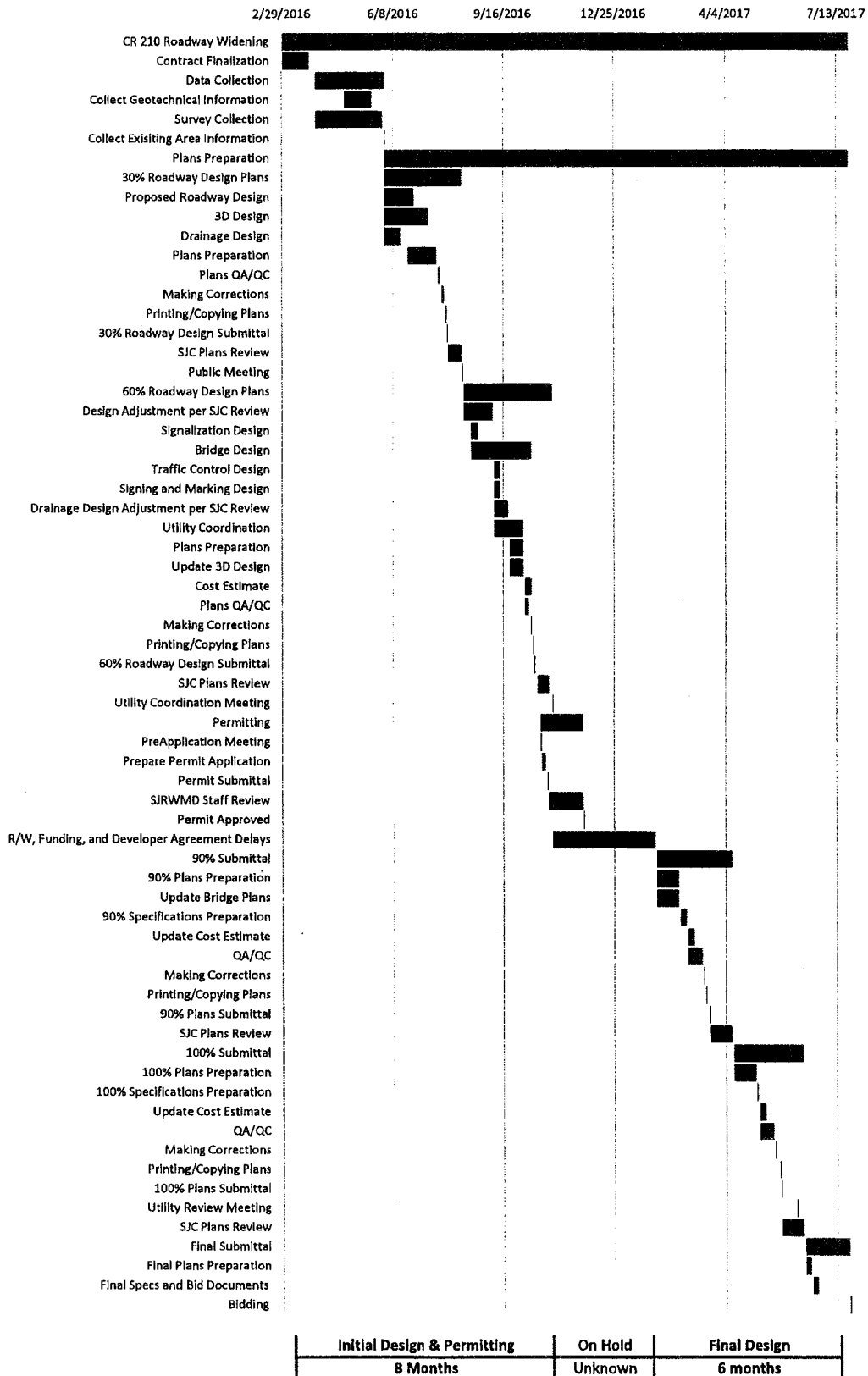

# ADMINISTRATIVE INFORMATION





# CERTIFICATE OF LIABILITY INSURANCE

DATE(MM/DD/YYYY)  
06/11/2015

THIS CERTIFICATE IS ISSUED AS A MATTER OF INFORMATION ONLY AND CONFERS NO RIGHTS UPON THE CERTIFICATE HOLDER. THIS CERTIFICATE DOES NOT AFFIRMATIVELY OR NEGATIVELY AMEND, EXTEND OR ALTER THE COVERAGE AFFORDED BY THE POLICIES BELOW. THIS CERTIFICATE OF INSURANCE DOES NOT CONSTITUTE A CONTRACT BETWEEN THE ISSUING INSURER(S), AUTHORIZED REPRESENTATIVE OR PRODUCER, AND THE CERTIFICATE HOLDER.

**IMPORTANT:** If the certificate holder is an ADDITIONAL INSURED, the policy(ies) must be endorsed. If SUBROGATION IS WAIVED, subject to the terms and conditions of the policy, certain policies may require an endorsement. A statement on this certificate does not confer rights to the certificate holder in lieu of such endorsement(s).

<b>PRODUCER</b> Aon Risk Services South, Inc. Franklin TN Office 501 Corporate Centre Drive Suite 300 Franklin TN 37067 USA	<b>CONTACT NAME:</b> PHONE (A/C. No. Ext.): (866) 283-7122      FAX (A/C. No.): (800) 363-0105	
	<b>E-MAIL ADDRESS:</b>	
<b>INSURED</b> Arcadis U.S, Inc. 630 Plaza Drive Suite 200 Highlands Ranch CO 80129 USA	<b>INSURER(S) AFFORDING COVERAGE</b>	
	<b>INSURER A:</b> Lexington Insurance Company <b>NAIC #</b> 19437	
	<b>INSURER B:</b> Steadfast Insurance Company      26387	
	<b>INSURER C:</b>	
	<b>INSURER D:</b>	
	<b>INSURER E:</b>	

**COVERAGES**      **CERTIFICATE NUMBER: 570058032758**      **REVISION NUMBER:**

THIS IS TO CERTIFY THAT THE POLICIES OF INSURANCE LISTED BELOW HAVE BEEN ISSUED TO THE INSURED NAMED ABOVE FOR THE POLICY PERIOD INDICATED. NOTWITHSTANDING ANY REQUIREMENT, TERM OR CONDITION OF ANY CONTRACT OR OTHER DOCUMENT WITH RESPECT TO WHICH THIS CERTIFICATE MAY BE ISSUED OR MAY PERTAIN, THE INSURANCE AFFORDED BY THE POLICIES DESCRIBED HEREIN IS SUBJECT TO ALL THE TERMS, EXCLUSIONS AND CONDITIONS OF SUCH POLICIES. LIMITS SHOWN MAY HAVE BEEN REDUCED BY PAID CLAIMS.      **Limits shown are as requested**

INSR LTR	TYPE OF INSURANCE	ADDL INSD	SUBR WVD	POLICY NUMBER	POLICY EFF (MM/DD/YYYY)	POLICY EXP (MM/DD/YYYY)	LIMITS
	<b>COMMERCIAL GENERAL LIABILITY</b> <input type="checkbox"/> CLAIMS-MADE <input type="checkbox"/> OCCUR  <b>GEN'L AGGREGATE LIMIT APPLIES PER:</b> <input type="checkbox"/> POLICY <input type="checkbox"/> PRO-JECT <input type="checkbox"/> LOC OTHER:						EACH OCCURRENCE DAMAGE TO RENTED PREMISES (Ea occurrence) MED EXP (Any one person) PERSONAL & ADV INJURY GENERAL AGGREGATE PRODUCTS - COMP/OP AGG
	<b>AUTOMOBILE LIABILITY</b> <input type="checkbox"/> ANY AUTO <input type="checkbox"/> ALL OWNED AUTOS <input type="checkbox"/> HIRED AUTOS <input type="checkbox"/> SCHEDULED AUTOS <input type="checkbox"/> NON-OWNED AUTOS						COMBINED SINGLE LIMIT (Ea accident) BODILY INJURY (Per person) BODILY INJURY (Per accident) PROPERTY DAMAGE (Per accident)
	<b>UMBRELLA LIAB</b> <input type="checkbox"/> OCCUR <b>EXCESS LIAB</b> <input type="checkbox"/> CLAIMS-MADE DED    RETENTION						EACH OCCURRENCE AGGREGATE
	<b>WORKERS COMPENSATION AND EMPLOYERS' LIABILITY</b> ANY PROPRIETOR / PARTNER / EXECUTIVE OFFICER/ MEMBER EXCLUDED? (Mandatory in NH) If yes, describe under DESCRIPTION OF OPERATIONS below		Y/N	N/A			PER STATUTE    OTH-ER E.L. EACH ACCIDENT E.L. DISEASE-EA EMPLOYEE E.L. DISEASE-POLICY LIMIT
B	Contractor Poll			IPR929693801 Professional & Pollution SIR applies per policy terms & conditions	06/01/2015	06/01/2016	Each Claim      \$1,000,000 Annual Aggregate      \$1,000,000

**DESCRIPTION OF OPERATIONS / LOCATIONS / VEHICLES (ACORD 101, Additional Remarks Schedule, may be attached if more space is required)**  
For Professional Liability coverage, the Aggregate Limit is the total insurance available for claims presented within the policy period for all operations of the insured. The Limit will be reduced by payments of indemnity and expense.

### CERTIFICATE HOLDER

Arcadis U.S, Inc.  
630 Plaza Drive, Suite 200  
Highlands Ranch CO 80129 USA

### CANCELLATION

SHOULD ANY OF THE ABOVE DESCRIBED POLICIES BE CANCELLED BEFORE THE EXPIRATION DATE THEREOF, NOTICE WILL BE DELIVERED IN ACCORDANCE WITH THE POLICY PROVISIONS.

AUTHORIZED REPRESENTATIVE

*Aon Risk Services South Inc.*

Holder Identifier :

Certificate No : 570058032758





## St. Johns County Board of County Commissioners

Purchasing Division

December 17, 2015

### ADDENDUM #1

**To:** Prospective Bidders  
**From:** St. Johns County Purchasing Department  
**Subject:** RFQ No. 16-21 County Road 210 Widening – Greenbriar Rd. to Cimarrone Blvd.

This Addendum #1 is issued for further bidder's information and is hereby incorporated into the bid documents. Each bidder will ascertain before submitting a proposal that he/she has received all Addenda.

**Please return an original copy of this signed Addendum with proposal to the St. Johns County Purchasing Department, Karen Fullerton, Procurement Supervisor; 500 San Sebastian View; St. Augustine, FL 32084.**

#### Questions:

1. Are the one page resumes restricted to the same margins, font style and font size as the core response? Most firms maintain a library of resumes in their own unique style.

Yes, the resumes are restricted to the same margins, font style and font size as the core response.

2. For the list of Sub-Consultants with Credentials and Related Experience, is this limited to one page per Sub-consultant? One page for all, together with the font and margin restrictions, will be very limiting in content for reviewers.

The maximum page limit per Sub-Consultant is one page.

**RFQ Due Date remains February 4, 2016 at 4:00 P.M.**

Acknowledgment

A handwritten signature in cursive script, appearing to read "Gene Howerton", written over a horizontal line.

Signature and Date

Gene Howerton/Vice President

Printed Name/Title

Arcadis U.S., Inc.

Company Name (Print)

Sincerely,

Karen R. Fullerton  
Procurement Supervisor

**END OF ADDENDUM NO. 1**



## St. Johns County Board of County Commissioners

Purchasing Division

January 19, 2016

### ADDENDUM #2

**To: Prospective Bidders**

**From: St. Johns County Purchasing Department**

**Subject: RFQ No. 16-21 County Road 210 Widening – Greenbriar Rd. to Cimarrone Blvd.**

This Addendum #2 is issued for further bidder's information and is hereby incorporated into the bid documents. Each bidder will ascertain before submitting a proposal that he/she has received all Addenda.

**Please return an original copy of this signed Addendum with proposal to the St. Johns County Purchasing Department, Karen Fullerton, Procurement Supervisor; 500 San Sebastian View; St. Augustine, FL 32084.**

#### Questions:

1. Regarding Section 3; Bullet Item 5 - "Include a list of sub-consultants with credentials and related experience" and considering the statement made at the Pre-Proposal meeting to not provide separate resumes for sub-consultants: For an included subconsultant firm proposed in a primary teaming partner role intended to provide complementary Design task services as part of the overall Design team, we planned to highlight their key personnel skills and experience in a similar fashion as ours by providing respective 1-page resumes. These key personnel would have a primary role in the project Design success and thus provide a full representation to the selection committee members regarding the comprehensive qualifications and experience offered by the proposed overall Design team. This would be limited to primary subconsultant firms proposed to be engaged in the specific Design team tasks; not the typical secondary project support sub-consultants such as survey, environmental/wetlands, geotechnical, etc. Will this be allowed?

If a submitting firm is partnering with another firm with the intent to provide complementary Design task services as part of the overall Design team, which was encouraged at the non-mandatory pre-proposal meeting, then yes, providing a one (1) page resume for the key personnel or core project team members from the partnering firm is acceptable. This acceptance is not intended to allow one (1) page resumes for sub-consultants who provide specialty services, such as survey, environmental/wetlands, geotechnical, structural, traffic, etc.

2. Part III: General Requirements, Bullet B, Heading Environmental, Page 6 – Under this section it states that the ESA shall be performed by a Florida Registered Environmental Engineering Firm. Would a Florida Registered Geologist be acceptable for this task?

The ESA may be performed by a Florida Registered Geologist as long as the proper Professional Liability Insurance is carried. Professional Liability Insurance Requirements for a Florida Registered Geologist are as follows: The

CONTRACTOR shall maintain during the life of the contract, Professional Liability or Errors and Omissions Insurance with minimum limits of \$1,000,000, if applicable.

Clarifications/Information:

1. This project is a developer funded project and will have a longer development time. Potentially, it could be a three to five year time period for design until the beginning of construction.

2. Page 11, RFQ Package Components, Section 3, Company and Staff Qualifications

For clarifications purposes, key personnel are considered the core project team members. Provide one page resumes for each project team member.

Further clarification, in this same section, the Company Qualifications is limited to 4 pages total, not for each of the prime company and/or partnering company.

3. A map was provided at the non-mandatory pre-proposal meeting on January 14, 2016. The map is will be uploaded to Demand Star for all plan holders to access and is included in this Addendum.

**RFQ Due Date remains February 4, 2016 at 4:00 P.M.**

**Acknowledgment**

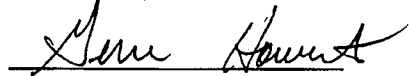

Signature and Date

Gene Howerton/Vice President

Printed Name/Title

Arcadis U.S., Inc.

Company Name (Print)

Sincerely,

Karen R. Fullerton  
Procurement Supervisor

**END OF ADDENDUM NO. 2**

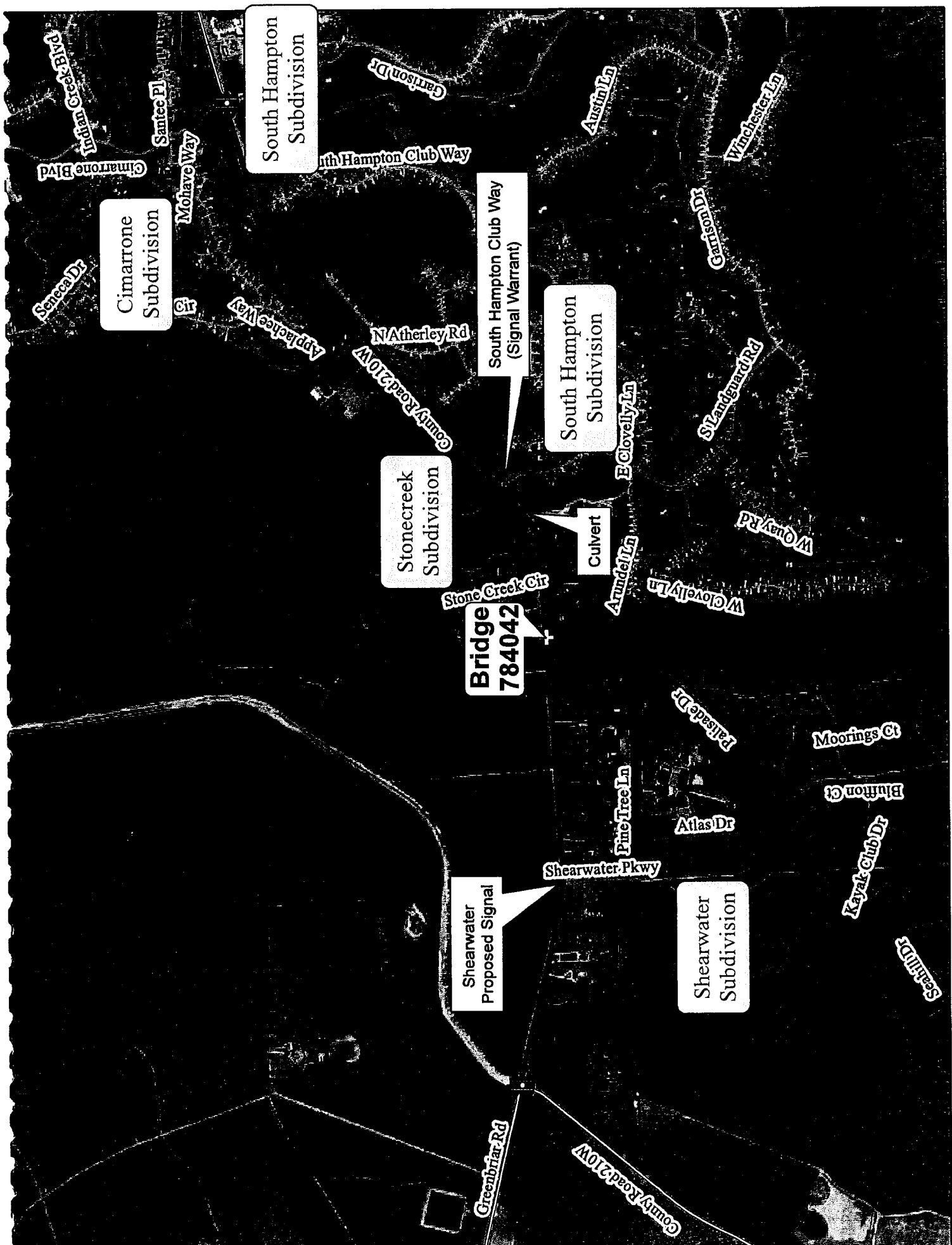

South Hampton Subdivision

Cimarrone Subdivision

Stonecreek Subdivision

South Hampton Subdivision

Shearwater Subdivision

Shearwater Proposed Signal

South Hampton Club Way (Signal Warrant)

Bridge 784042

Culvert

Indian Creek Blvd

Santee Pl

Mohave Way

Garrison Dr

South Hampton Club Way

Austin Ln

Winchester Ln

Garfield Dr

Seneca Dr

Apache Way

N Atherley Rd

County Road 210W

South Hampton Club Way (Signal Warrant)

South Hampton Subdivision

E Clovelly Ln

St Landguard Rd

W Quay Rd

Stonecreek Subdivision

Stone Creek Cir

Amundson Ln

W Clovelly Ln

Bridge 784042

Palmer Dr

Moorings Ct

Blythton Ct

Pine Tree Ln

Atlas Dr

Kayak Club Dr

Shearwater Pkwy

Seal Dr

Greenbriar Rd

County Road 210W



# St. Johns County Board of County Commissioners

Purchasing Division

January 25, 2016

## ADDENDUM #3

**To:** Prospective Bidders  
**From:** St. Johns County Purchasing Department  
**Subject:** RFQ No. 16-21 County Road 210 Widening – Greenbriar Rd. to Cimarrone Blvd.

This Addendum #3 is issued for further bidder's information and is hereby incorporated into the bid documents. Each bidder will ascertain before submitting a proposal that he/she has received all Addenda.

Please return an original copy of this signed Addendum with proposal to the St. Johns County Purchasing Department, Karen Fullerton, Procurement Supervisor; 500 San Sebastian View; St. Augustine, FL 32084.

### Questions:

1. Page 11, RFQ Package Components, Section 3, Company and Staff Qualifications:  
Page #2 of Addendum #2 notes that Company Qualifications is limited to 4 pages total. Does this mean our write-up describing our company and team qualifications is limited to 4 pages, not inclusive of resumes, organizational chart, list of sub-consultants, business licenses and certifications? Or are all of some of these supporting documents to be included in the 4 pages?

The limitation of 4 pages for the Company and Team Qualifications does not include resumes, the organizational chart, list of sub-consultants, business licenses, and certifications.

**RFQ Due Date remains February 4, 2016 at 4:00 P.M.**

**Acknowledgment**

A handwritten signature in black ink, appearing to read "Gene Howerton", written over a horizontal line.

Signature and Date

Gene Howerton/Vice President

Printed Name/Title

Arcadis U.S., Inc.

Company Name (Print)

Sincerely,

Karen R. Fullerton  
Procurement Supervisor

**END OF ADDENDUM NO. 3**

**REQUEST FOR QUALIFICATIONS (RFQ) NO: 16-21  
CR 210 Widening - Greenbriar Rd. to Cimarrone Blvd.  
Professional Engineering Services**

**Company Name:** Arcadis U.S. Inc.

**St. Johns County Board of County Commissioners  
Drug-Free Workplace Form**

The undersigned firm, in accordance with Florida Statute 287.087 hereby certifies that

Arcadis U.S. Inc. does:  
Name of Firm

1. Publish a statement notifying employees that the unlawful manufacture, distribution, dispensing, possession or use of a controlled substance is prohibited in the workplace and specifying the actions that will be taken against employees for violations of such prohibition.
2. Inform employees about the danger of drug abuse in the workplace, the business' policy of maintaining a drug-free workplace, any available drug counseling, rehabilitation, employee assistance programs and the penalties that may be imposed upon employees for drug abuse violations.
3. Give each employee engaged in providing the contractual services that are described in St. Johns County's request for proposals to provide bond underwriter services a copy of the statement specified in paragraph 1.
4. In the statement specified in paragraph 1, notify the employees that, as a condition of working on the contractual services described in paragraph 3, the employee will abide by the terms of the statement and will notify the employer of any conviction of, or plea of guilty or nolo contendere to, any violation of Florida Statute 893, as amended, or of any controlled substance law of the United States or any state, for a violation occurring in the workplace no later than five (5) days after such conviction or plea.
5. Impose a sanction on, or require the satisfactory participation in a drug abuse assistance or rehabilitation program if such is available in the employee's community by, any employee who is so convicted.
6. Consistent with applicable provisions with State or Federal law, rule, or regulation, make a good faith effort to continue to maintain a drug-free workplace through implementation of paragraphs 1 through 5.

As the person authorized to sign this statement, I certify that this firm complies fully with the above requirements.

  
\_\_\_\_\_  
Signature

February 3, 2016  
Date

**REQUEST FOR QUALIFICATIONS (RFQ) NO: 16-21  
CR 210 Widening - Greenbriar Rd. to Cimarrone Blvd.  
Professional Engineering Services**

**AFFIDAVIT**

TO: ST. JOHNS COUNTY BOARD OF COUNTY COMMISSIONERS  
ST. AUGUSTINE, FLORIDA

At the time the proposal is submitted, the Respondent shall attach to his proposal a sworn statement.

The sworn statement shall be an affidavit in the following form, executed by an officer of the firm, association or corporation submitting the proposal and shall be sworn to before a person who is authorized by law to administer oaths.

STATE OF Florida COUNTY OF Duval. Before me, the undersigned authority, personally appeared Gene Howerton who, being duly sworn, deposes and says he is Vice President (Title) of Arcadis, U.S., Inc. (Firm) the respondent submitting the attached proposal for the services covered by the RFQ documents for RFQ No: 16-21 CR 210 Widening - Professional Engineering Services.

The affiant further states that no more than one proposal for the above referenced project will be submitted from the individual, his firm or corporation under the same or different name and that such respondent has no financial interest in the firm of another respondent for the same work, that neither he, his firm, association nor corporation has either directly or indirectly entered into any agreement, participated in any collusion, or otherwise taken any action in restraint of free competitive bidding in connection with this firm's proposal on the above described project. Furthermore, neither the firm nor any of its officers are debarred from participating in public contract lettings in any other state.

Arcadis U.S., Inc.  
(Proposer)  
By *Gene Howerton*  
Vice President  
(Title)

STATE OF Florida )  
COUNTY OF Duval )

Subscribed and sworn to before me this 2<sup>ND</sup> day of FEBRUARY, 2016, by Gene Howerton who personally appeared before me at the time of notarization, and who is personally known to me or who has produced as identification.

*Maria A Birch*  
Notary Public

My commission expires:  
July 26, 2017

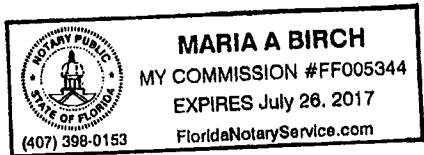

**VENDOR ON ALL COUNTY PROJECTS MUST EXECUTE AND ATTACH THIS AFFIDAVIT TO EACH PROPOSAL.**

REQUEST FOR QUALIFICATIONS (RFQ) NO: 16-21  
CR 210 Widening - Greenbriar Rd. to Cimarrone Blvd.  
Professional Engineering Services

AFFIDAVIT OF SOLVENCY

PERTAINING TO THE SOLVENCY OF Arcadis U.S. Inc., being of lawful age and being duly sworn I, Gene Howerton  
\_\_\_\_\_ as Vice President (ex. CEO, officer, president, duly authorized representative, etc.) hereby certify under  
penalty of perjury that:

1. I have reviewed and am familiar with the financial status of above stated entity.
2. The above stated entity possesses adequate capital in relation to its business operations or any contemplated or undertaken transaction to timely pay its debts and liabilities (including, but not limited to, unliquidated liabilities, unmatured liabilities and contingent liabilities) as they become absolute and due.
3. The above stated entity has not, nor intends to, incur any debts and/or liabilities beyond its ability to timely pay such debts and/or liabilities as they become due.
4. I fully understand failure to make truthful disclosure of any fact or item of information contained herein may result in denial of the application, revocation of the Certificate of Public Necessity if granted and/or other action authorized by law.

The undersigned has executed this Affidavit of Solvency, in his/her capacity as a duly authorized representative of the above stated entity, and not individually, as of this 2<sup>nd</sup> day of February, 2016.

Gene Howerton  
Signature of Affiant

STATE OF Florida )

COUNTY OF Duval )

Subscribed and sworn to before me this 2<sup>nd</sup> day of February, 2016, by Gene Howerton  
who personally appeared before me at the time of notarization, and who is personally known to me or who has produced  
\_\_\_\_\_ as identification.

Maria A Birch  
Notary Public

My commission expires:  
July 26, 2017

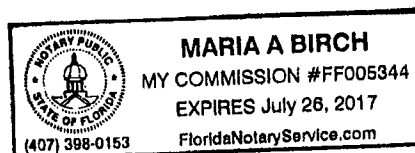

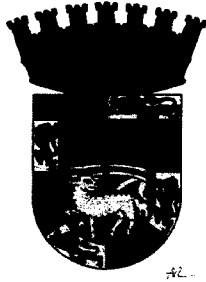

**ST. JOHNS COUNTY  
BOARD OF COUNTY COMMISSIONERS**

**RFQ NO: 16-21  
REQUEST FOR QUALIFICATIONS**

**County Road (CR) 210 Widening  
Greenbriar Rd. to Cimarrone Blvd.  
Professional Engineering Services**

**St. Johns County Purchasing Department  
500 San Sebastian View  
St. Augustine FL 32084**

**FINAL: 11/23/15**

**REQUEST FOR QUALIFICATIONS (RFQ) NO: 16-21  
PROFESSIONAL ENGINEERING SERVICES**

**TABLE OF CONTENTS**

- I. Advertisement**
- II. Introduction**
  - A. Purpose
  - B. RFQ Contact Information for Questions
  - C. Addenda
  - D. Pre-Proposal Meeting
  - E. Due Date & Location
  - F. RFQ Response Packaging Instructions
  - G. Evaluation of Responses
  - H. Evaluation Criteria
  - I. Contract Award
  - J. Contract Performance
- III. General Requirements**
  - A. Project Description
  - B. Scope of Work
  - C. Sub-Consultants
- IV. Contract Requirements**
  - A. Insurance Requirements
  - B. Licenses, Permits & Fees
  - C. Contract Agreement & Term
  - D. Governing Laws & Regulations
  - E. Termination
  - F. Indemnification
  - G. Trade Secrets
  - H. Public Records
  - I. Use of County Logo
- V. Request for Qualifications Submittal Requirements**
  - A. Respondent Responsibilities
  - B. RFQ Package Submittal Format
  - C. RFQ Package Components
- VI. Evaluator's Score Sheet Example**
- VII. Attachments / Forms**
- VIII. Optional Checklist**
- IX. Sealed Bid Mailing Label**

**ST. JOHNS COUNTY FL – RFQ NO: 16-21 CR 210 Widening – Professional Engineering Services**

**PART I: ADVERTISEMENT**

Notice is hereby given that St. Johns County, FL is soliciting responses for **RFQ No: 16-21 CR 210 Widening - Professional Engineering Services**. Interested and qualified respondents may submit RFQ Packages, according to the requirements described herein, to the St. Johns County Purchasing Department. All RFQ Packages are due by or before 4:00PM (EST) on **Thursday, February 4, 2016**. Any packages delivered to or received after the 4:00PM deadline will not be considered and shall be returned unopened to the addressee.

In accordance with Florida Statutes, Section 287.055 Consultant's Competitive Negotiation Act (CCNA), St. Johns County Board of Commissioners solicits responses from qualified and experienced firms to provide Professional Engineering Services for the widening of CR 210 from two lanes to four lanes from Greenbriar Road to Cimmarrone Boulevard, approximately 12,000 ft. (2.27 miles).

RFQ Packages are available for downloading from Onvia Demandstar, Inc., at their website [www.demandstar.com](http://www.demandstar.com), or by calling 800-711-1712 and requesting Document #16-21. Vendors registered with Demandstar may download most packages at no cost from the website. Download fees may apply to vendors not registered on the website. Packages are also available from the SJC Purchasing Department. When making a request provide the full company name, full company address, company phone number, primary contact and email address.

Any and all questions or requests for information relating to this Request for Qualification shall be **submitted in writing** by or before close of business (5:00PM) on **Thursday, January 21, 2016**.

**Contact Information:** Karen Fullerton, Procurement Supervisor  
SJC Purchasing Department  
500 San Sebastian View  
St. Augustine FL 32084  
Email: [kfullerton@sjcfl.us](mailto:kfullerton@sjcfl.us)  
Fax: (904) 209-0163

**Interested firms may not contact any staff member of St. Johns County, except the above referenced individual, with regard to this RFQ as stated in SJC Purchasing Code 304.6.5 "Procedures Concerning Lobbying". All inquiries will be routed to the appropriate staff member for response.**

**PRE-PROPOSAL MEETING:** There will be a **Non-Mandatory** Pre-Proposal meeting on **Thursday, January 14, 2016 at 10:00 a.m.** in the **St. Johns County Utility Department, 1205 State Road 16, St. Augustine, FL 32084**. All firms interested in submitting a proposal package are invited to attend this meeting.

RFQ Packages **MUST** be submitted in a **SEALED** envelope/container and clearly marked on the exterior of the package. Each package submitted must have the respondent's name and mailing address marked plainly on the outside of the envelope/container. Each package shall consist of one (1) original and five (5) copies of the RFQ Package which shall include all required documents and any supplemental information.

**Deliver or Ship RFQ Packages to:** St. Johns County Purchasing Department  
500 San Sebastian View  
St. Augustine FL 32084

*Vendors shall not contact, lobby or otherwise communicate with any SJC employee, including any member of the Board of County Commissioners, other than the above referenced individual from the point of advertisement of the RFQ until contract(s) are executed by all parties, per SJC Purchasing Code 304.6.5 "Procedures Concerning Lobbying". According to SJC policy, any such communication shall disqualify the vendor or Contractor from responding to the subject invitation to bid, request for quote, request for proposal, invitation to negotiate or request for proposals and possible debarment for periods up to twelve (12) months.*

Any bidder, proposer or person substantially and adversely affected by an intended decision or by any term, condition, procedure or specification with respect to any bid, invitation, solicitation of proposals or request for qualifications, shall file with the Purchasing Department for St. Johns County, a written notice of intent to protest no later than seventy two (72) hours

(excluding Saturdays, Sundays, and legal holidays for employees of St. Johns County) after the posting either electronically or by other means of the notice of intended action, notice of intended award, bid tabulation, publication by posting electronically or by other means of a procedure, specification, term or condition which the person intends to protest, or the right to protest such matter shall be waived. The protest procedures may be obtained from the Purchasing Department and are included in St. Johns County's Purchasing Manual. All of the terms and conditions of the County's Purchasing Manual are incorporated by reference and are fully binding.

## **PART II: INTRODUCTION**

### **A. Purpose:**

St. Johns County Purchasing Department on behalf of St. Johns County Engineering Department is accepting sealed Request for Qualification packages from qualified and experienced firms to be considered for providing Professional Engineering Services for the widening of CR 210 from two lanes to four lanes from Greenbriar Road to Cimmarrone Boulevard, approximately 12,000 ft. (2.27 miles).

### **B. RFQ Contact Information for Questions:**

Any and all questions or requests for information relating to this Request for Qualification shall be **submitted in writing** by or before close of business (5:00PM) on **Thursday, January 21, 2016**.

**Contact Information:** Karen Fullerton, Procurement Supervisor  
SJC Purchasing Department  
500 San Sebastian View  
St. Augustine FL 32084  
Email: [kfullerton@sjcfl.us](mailto:kfullerton@sjcfl.us)  
Fax: (904) 209-0163

**Interested firms may not contact any staff member of St. Johns County, except the above referenced individual, with regard to this RFQ as stated in SJC Purchasing Code 304.6.5 "Procedures Concerning Lobbying". All inquiries will be routed to the appropriate staff member for response.**

### **C. Addenda:**

Any and all clarifications, answers to questions, or changes to this RFQ shall be provided through a County issued Addendum, posted on [www.demandstar.com](http://www.demandstar.com). Any clarifications, answers, or changes provided in any manner other than a formally issued addendum, are to be considered "unofficial" and shall not bind the County to any requirements, terms or conditions not stated herein.

The County shall make every possible, good faith effort to issue any and all addenda no later than seven (7) days prior to the due date for proposals. Any addenda issued after this date, shall be for material, necessary clarifications to the Request for Qualification.

**D. PRE-PROPOSAL MEETING:** There will be a **Non-Mandatory** Pre-Proposal meeting on **Thursday, January 14, 2016 at 10:00 a.m.** in the **St. Johns County Utility Department, 1205 State Road 16, St. Augustine, FL 32084**. All firms interested in submitting a proposal package are invited to attend this meeting.

### **E. Due Date & Location:**

Packages submitted in response to this Request for Qualification must be delivered to, and received by the SJC Purchasing Department by or before four o'clock (4:00PM) on **Thursday, February 4, 2016**. Any packages received after this deadline will be deemed unresponsive, and shall be returned to the addressee unopened.

**RFQ Packages shall be delivered to:** St. Johns County Purchasing Department  
500 San Sebastian View  
St. Augustine, FL 32084

### **F. RFQ Response Packaging Instructions:**

1. To be considered, submit one (1) original and five (5) copies of the RFQ proposal, which shall include all required documentation and any supplemental information.
2. RFQ Packages must be in a **SEALED** envelope/container and clearly marked on the exterior of the package: Each package submitted must also have the respondent's company name and mailing address marked plainly on the exterior

of the envelope/container.

- 3. Affix label, found at the end of this RFQ document, to sealed envelope/container.

**G. Evaluation of Responses:**

All properly submitted RFQ Packages shall be evaluated by an Evaluation Committee. Each Evaluation Committee Team Member will receive a set of all of the RFQ Packages submitted, a copy of the RFQ Document with all issued Addenda, and an Evaluator’s Score Sheet. The Team shall then evaluate each RFQ Package according to the criteria described herein. Each Evaluation Team Member shall evaluate the RFQ Packages individually, with no communication, coordination, or influence from any other Evaluation Team Member, or any other individual. Scores for each Respondent shall be recorded on the Evaluator’s Score Sheet. A public Evaluation Meeting will be held by the SJC Purchasing Department to record the scores from each Evaluation Committee Member, and rank the firms’ scores highest to lowest.

The County desires to avoid the expense to all parties of unnecessary presentations; however, the County may elect to conduct oral interviews or presentations from one or more of the respondents in order to make a final determination of the top rankings. If the County elects to conduct oral interviews or presentations, selected firms will be notified. All such presentations or interviews shall be open to the public.

County Staff may consider any evidence available regarding financial, technical, other qualifications and abilities of a respondent, including past performance (experience) with the County prior to recommending approval of award to the St. Johns County Board of County Commissioners.

The St. Johns County Board of County Commissioners reserves the right to reject any or all proposals, waive minor formalities or award to / negotiate with the firm whose proposal best serves the interest of the County.

**H. Evaluation Criteria:**

It is the intention of St. Johns County to evaluate, and rank the respondents that submit RFQ Packages from highest to lowest utilizing the evaluation criteria listed below.

Evaluation of the responses to this RFQ will comply with the specific criteria as follows:

<u>Evaluation Criteria:</u>	<u>Maximum Possible Points per Evaluator:</u>
A. Company and Staff Qualifications	10
B. Related Experience	25
C. Project Approach & Innovation	50
D. Quality & Schedule Control	5
E. Quality of Submittal	<u>5</u>
<b>Total Points Possible:</b>	<b>95</b>

**I. Contract Award:**

Recommendation shall be made to the Board of County Commissioners by County Staff to enter into negotiations with the highest ranked firm with the intention of coming to agreement over terms, conditions, and pricing in order to award a Contract for the services described herein.

**J. Contract Performance:**

At any point in time during the term of the Contract with the awarded Consultant, County Staff may review records of performance to ensure that the Consultant is continuing to provide sufficient financial support, equipment and organization as prescribed herein. The County may place said contract on probationary status and implement termination procedures if the County determines that a Consultant no longer possesses the financial support, equipment and organization which would have been necessary during the RFQ evaluation period in order to comply with this demonstration of competency section.

**PART III: GENERAL REQUIREMENTS**

**A. Project Description:**

This project will consist of engineering design, survey, permitting for widening from two lanes to four lanes of County Road 210 from Greenbriar Road to Cimmarrone Blvd. approximately 12,000 ft. (2.27 miles).

**B. Scope of Work:**

The scope of services for this project shall include providing complete engineering design, permitting, right of way

acquisition, utility coordination services, and construction documents for the 4 laning of County Road (CR) 210 Widening from Greenbriar Road to Cimarrone Blvd. including improvements to the Greenbriar/CR 210/CR 223, and CR 210/Shearwater Parkway, and CR 210 / South Hampton Club Way.

Engineering services to be provided under this Request for Qualifications (RFQ) shall include, but may not be limited to, the following:

- **Engineering Design** – Includes the design and permitting of all plans and specifications necessary for all required divisions of work including but not limited to site work, geotechnical, structural for bridge and culverts, traffic signals, and landscape as necessary.
  - **Plan Design** – Design may include plan submittals at 30%, 60%, and 100% with reviews at each stage. Plans shall be designed to 60% and permitted at a minimum. Due to timing of developer funding, 100% plans and bid documents may be delayed for a few years when full funding becomes available for construction. The roadway shall be designed and constructed as a 4 lane with future 6 laning considered for all elements including stormwater retention. The consultant shall use the appropriate County Typical section. The roadway shall have paved shoulders (bike lanes), sidewalks on both sides.
  - **Survey:** The consultant shall be responsible for all survey requirements including, but not limited to design topography, right of way mapping, descriptions for temporary construction easements, permanent easements, right of way parcel acquisitions, and stormwater pond parcels. County LIDAR is available for preliminary use only. NAVD 88 Datum or newer shall be used. Coordination with the St. Johns County Real Estate Division will be required during the parcel and easement acquisition phases.
  - **Geotechnical:** The consultant shall use a Florida Registered Geotechnical Engineering firm for soil borings necessary for design and permitting including any pond sites and signal foundations.
  - **Environmental:** The consultant shall avoid and minimize wetland impacts. The consultant shall coordinate with the St. Johns County Environmental Department on mitigation. A Phase 1 Environmental Site Assessment (ESA) shall be required for any acquired right of way including pond sites. The ESA shall be performed by a Florida Registered Environmental Engineering firm.
  - **Stormwater Retention Ponds:** The project may require stormwater ponds. The consultant shall determine the size and final location of all ponds and outfall structures. The consultant may consider a joint use pond with and existing development through drainage easements. The consultant may consider analyzing the existing ponds for excess capacity. Modifications to existing ponds may be required including enlargement or changes to the outfall structure. The last option to be considered is acquiring property for a new pond. New ponds may be required to be fenced. The ponds shall be permitted through regulatory agencies.
  - **Permitting:** The Consultant shall permit the project with all applicable agencies. Permitting fees shall be determined by the regulatory agency through the consultant. The consultant shall request a check for the fee from the County. Permits may be required from but not limited to the St. Johns River Water Management District, and U.S. Army Corp of Engineers.
  - **Bridges and Culverts:** Shall be designed using Florida Department of Transportation guidelines and specifications. The replacement bridge shall be designed and constructed with 6 lanes and striped out for 4 lanes. Cross Culverts should be designed and constructed for 6 lanes. A Bridge Hydraulic report and a Load Rating Analysis shall be required for any structure classified as a bridge. During project closeout the consultant shall submit these items along with Pile Driving Records, if used and supplied by the Contractor to the Florida Department of Transportation (FDOT) for initial inspection purposes. The consultant shall also request a new bridge number from the FDOT during design to be placed on the structure.
  - **Intersection Improvements and Traffic Signals:** The Consultant shall design intersection improvements for the County Road (CR) 210 / Greenbriar/ CR 223 intersection including signal. The intersection shall require the turn lanes on all approaches including the future CR 223 on the north side of the intersection. Intersection improvements shall be required at CR 210 / Shearwater Parkway intersection including turn lanes and

signalization. The consultant shall also examine the CR 210 / South Hampton Club Way for intersection improvements including traffic signal warrant study. If warranted, a traffic signal shall be designed. Finally the consultant shall examine the CR 210 / Cimarrone Blvd to ensure that the existing intersection does not require any improvements. Traffic Signals should be designed with future 6 laning in mind including mast arm location. Galvanized Mast Arm Signals shall be designed. The consultant will coordinate with County Traffic Operations during design and review of plans. Traffic Controller assemblies shall be designed using equipment approved by Traffic Operations and be compatible with the existing county network. Traffic signals timing shall be coordinated via wireless technology. Signals shall have detection cameras for presence and a camera for intersection observation purposes only. Signals shall also have intersection lighting provided on the mast arms to assist with vehicle presence detection. Signals shall be designed to tie into the existing county network at the Public Works Facility.

- **Utility Coordination:** The consultant shall provide Utility Coordination. This shall entail coordination of relocation with all utilities affected by the project. The consultant shall ensure the Utilities have designed and relocated prior to construction. The County shall not pay for redesign or relocation however; the consultant can pursue a separate contract with the Utility for design services. The consultant shall make sure utilities are relocated in a timely fashion. The may require the consultant to set up Coordination meetings periodically. This phase of work may coincide with design and continue after design is complete.
  - **Public Outreach and Social Media:** The consultant shall develop a public outreach plan to include public meetings during the design process. This will require the consultant to prepare public meeting displays, notification and assist the County with hosting the meetings. At a minimum, public meetings will be held at the 60% design plans. Homeowners Associations or other groups may request a separate meeting and the consultant should be prepared to interact with these groups. The consultant shall also set up, maintain and operate social media for the project possibly including Facebook, Twitter, or other sites as approved by the County. Social Media will be used throughout design, utility coordination, and construction phases.
  - **Peer Review:** The County may select, and separately contract with, another consultant firm to provide Peer Review of the Design. Peer Review firm shall be a separate company from the Design Consultant with no business ties. Peer Review may consist of examining all design submittals, providing comments to the Designer, resolving comments, constructability and permitting review. The firm will work directly for the County
- **Bid Documents** – Includes development and production of 100% bid documents to include all plans and specifications necessary to compile a complete bid package for the purpose of bidding the construction of this project. Production of 100% bid documents shall include coordination with the Civil and Geotechnical design firms selected by the County to include all plans and specifications applicable to those divisions of work. The final document package shall include providing an updated detailed Engineer’s estimate of probable cost and obtaining permits as required. The Consultant shall use the County’s boilerplate bid document and coordinate with the Purchasing Department on its development.
  - **Bidding Phase** – Includes assisting County staff with preparation of a complete Bid Document for the purpose of bidding this project as well as support services throughout the bid process. Support services shall include attendance at the Pre-Bid Meeting, responding to Requests for Information (RFI) and preparation of bid addendums throughout the bid process, distribution of bid packages to potential bidders, maintenance of a bidder/plan holder list, evaluation of bid proposals and preparation of a bid award recommendation.
  - **Construction Phase Services** – Includes assisting County staff throughout the construction of the project. Services shall include but may not be limited to attending at the Pre-Construction meeting, submittal/shop drawing review, responding to Requests for Information (RFI) throughout the construction period, periodic site visits to verify compliance with design documents and attendance at Project Progress Meetings.
  - **Project Close-Out** – Includes assisting County staff with all project close-out efforts including but not limited to project inspection/s to certify Substantial Completion, generation and/or monitoring of punch list items to ensure Final Completion/Acceptance within the project schedule, verification and approval of as-built drawings, completion and submission of all permits and/or certifications required by the project.

**C. Sub-Consultants:**

If the Consultant elects to sub-contract with any firm, for any portion of the work, the Consultant shall be responsible for all work performed by any sub-contract and the Consultant shall not be relieved of any obligations under this Contract.

Each Respondent shall submit a list of proposed sub-contracts to be used if awarded the contract. Each Respondent must provide a list of Sub-Consultants, under Section 1: Company and Staff Qualifications, and attach a copy of any and all licenses and certificates for each sub-contract listed and submit with each copy of the RFQ Package. If no sub-contracts are proposed, so state there on.

At any time, the County may, at its discretion, require any Respondent to submit all relevant data required to establish to the satisfaction of the County, the reliability and responsibility of the proposed sub-contracts to furnish and perform the work proposed.

Prior to the award of the Contract, the County will notify the Respondent in writing if the County, after due investigation, has reasonable and substantial objection to any person or organization proposed as a sub-contract. The Respondent then may, at his option, withdraw his RFQ Package, or submit an acceptable substitute at no increase in price. If the Respondent fails to submit an acceptable substitute within seven (7) days of the original notification, the County then may disqualify the Respondent, at no cost to the County.

The County reserves the right to disqualify any Consultant, Contractor, Sub-contractor, Vendor, or material supplier due to previously documented project problems, either with performance or quality.

Sub-contracts and other persons and organizations proposed by the Respondent and accepted by the County, must be used on the work for which they were proposed and accepted and shall not be changed except with the written approval of the County.

**PART IV: CONTRACT REQUIREMENTS**

**A. Insurance Requirements:**

The CONTRACTOR shall not commence work under this Contract until he/she has obtained all insurance required under this section and such insurance has been approved by the COUNTY. All insurance policies shall be issued by companies authorized to do business under the laws of the State of Florida. The CONTRACTOR shall furnish proof of Insurance to the COUNTY prior to the commencement of operations. The Certificate(s) shall clearly indicate the CONTRACTOR has obtained insurance of the type, amount, and classification as required by contract and that no material change or cancellation of the insurance shall be effective without thirty (30) days prior written notice to the COUNTY.

Certificates shall specifically include the COUNTY as Additional Insured for all lines of coverage except Workers' Compensation. A copy of the endorsement must accompany the certificate.

Certificate Holder Address: St. Johns County, FL  
500 San Sebastian View  
St. Augustine FL 32084

1. **Workers' Compensation:** The CONTRACTOR shall maintain during the life of this Contract, adequate Workers' Compensation Insurance in at least such amounts as are required by the law for all of its employees (if three or more) per Florida Statute 440.02.
2. **Comprehensive General Liability:** The CONTRACTOR shall maintain during the life of this Contract, Comprehensive General Liability with minimum limits of liability of \$1,000,000 per occurrence, \$2,000,000 aggregate, to protect the CONTRACTOR from claims for bodily injury, including wrongful death, as well as from claims of property damage which may arise from any operations under this contract, whether such operations be by the CONTRACTOR or anyone directly employed by or contracting with the CONTRACTOR.
3. **Comprehensive Automobile Liability:** The CONTRACTOR shall maintain during the life of this Contract, Comprehensive Automobile Liability Insurance with minimum limits of \$2,000,000 combined single limit for bodily injury and property damage liability to protect the CONTRACTOR from claims for damages for bodily injury, including the ownership, use, or maintenance of owned and non-owned automobiles, including rented/hired

automobiles whether such operations be by the CONTRACTOR or by anyone directly or indirectly employed by the CONTRACTOR.

In the event of unusual circumstances, the County Administrator or his designee may adjust these insurance requirements.

**B. Licenses, Permits & Fees:**

The Contractor shall be responsible for obtaining and holding any and all necessary licenses, permits, certifications required to perform the work described herein throughout the duration of the Contract. Payment of any fees or fines resulting in the lack of permits, licenses or certifications shall be the sole responsibility of the Contractor.

**C. Contract Agreement & Term:**

The intent of this RFQ is to select the number one ranked firm through the evaluation process and to award a contract upon successful negotiations to that firm. It is anticipated the County will issue a professional services contract for the duration of the project.

In the event that a Contract Agreement is attached to the RFQ, such attached Contract Agreement is for discussion purposes only, and not necessarily reflective of any Contract that may be ultimately entered into by the County. In the event that a Contract Agreement is not attached to the RFQ, it is expressly understood that the Board of County Commissioner's (Board's) preference/selection of any proposal does not constitute an award of a Contract Agreement with the County. It is anticipated that subsequent to the Board's preference/selection of any Proposal, Contract Negotiations will follow between the County and the selected Respondent. It is further expressly understood that no contractual relationship exists with the County until a Contract has been executed by both the County, and the selected Respondent. The County reserves the right to delete, add to, or modify one or more components of the selected Respondent's Proposal, in order to accommodate changed or evolving circumstances that the County may have encountered, since the issuance of the RFQ.

**D. Governing Laws & Regulations:**

It shall be the responsibility of the Consultant to be familiar and comply with any and all federal, state, and local laws, ordinances, rules and regulations relevant to the services to be performed under this Contract. The Contract Agreement shall be governed by the laws of the State of Florida and the County both as to interpretation and performance.

**E. Termination:**

Failure on the part of the Consultant to comply with any portion of the duties and obligations under the Contract Agreement shall be cause for termination. If the Contractor fails to perform any aspect of the responsibilities described herein, St. Johns County shall provide written notification stating any and all items of non-compliance. The Consultant shall then have seven (7) consecutive calendar days to correct any and all items of non-compliance. If the items of non-compliance are not corrected, or acceptable corrective action, as approved by the County, has not been taken within the seven (7) consecutive calendar days, the Contract Agreement may be terminated by St. Johns County for cause, upon giving seven (7) consecutive calendar days written notice to the Contractor.

In addition to the above, the County may terminate the Contract Agreement at any time, without cause, upon thirty (30) days written notice to the Consultant.

**F. Indemnification:**

To the fullest extent permitted by law, the Consultant shall indemnify and hold harmless St. Johns County, Florida, and employees from and against liability, claims, damages, losses and expenses, including attorney's fees, arising out of or resulting from performance of the Work, provided that such liability, claims, damage, loss or expense is attributable to bodily injury, sickness, disease or death, or injury to or destruction to tangible property (other than the Work itself) including loss of use resulting there from, but only to the extent caused in whole or in part by negligent acts or omissions of the Consultant, a Subconsultant, or anyone directly or indirectly employed by them or anyone for whose acts they may be liable, regardless of whether or not such liability, claim, damage, loss or expense is caused in part by a party indemnified hereunder.

**In claims against any person or entity indemnified under this Paragraph by an employee of the Consultant, a Subconsultant, any one directly or indirectly employed by them or anyone for whose acts they may be liable, the**

**indemnification obligation under this Paragraph shall not be limited by a limitation on amount or type of damages, compensation or benefits payable by or for the Consultant or a Subconsultant under workers' compensation acts, disability benefits acts or other employee benefit acts.**

**G. Trade Secrets:**

To invoke the provision of Florida Statute 624.4213, Trade Secrets, or other applicable law, the requesting firm must mark each page of such document or specific portion of a document claimed to be a trade secret must be clearly marked as "trade secret." All material marked as a trade secret must be separated from all non-trade secret material, such as being submitted in a separate envelope clearly marked as "trade secret." If the office or department receives a public records request for a document or information that is marked and certified as a trade secret, the office or department shall promptly notify the person that certified the document as a trade secret.

To invoke the provisions of Florida Statute 812.081, Trade Secrets, or other applicable law, the requesting firm must complete an Affidavit for Trade Secret Confidentiality, signed by an officer of the company, and submit the affidavit with the information classified as "Trade Secret" with other proposal documents. The affidavit must reference the applicable law or laws under which trade secret status is to be granted.

**H. Public Records:**

In accordance with Chapter 119 of the Florida Statutes (Public Records Law) and except as may be provided by other applicable State and Federal Law, all proposers should be aware that Request for Proposals and the responses thereto are in the public domain. However, the proposers are requested to identify specifically any information contained in their proposals which they consider confidential and/or proprietary and which they believe to be exempt from disclosure, citing specifically the applicable exempting law.

**I. Use of County Logo:**

Pursuant to, and consistent with, County Ordinance 92-2 and County Administrative Policy 101.3, the Contractor may not manufacture, use, display, or otherwise use any facsimile or reproduction of the County Seal/Logo without express written approval of the Board of County Commissioners of St. Johns County, Florida.

**PART V: REQUEST FOR QUALIFICATIONS SUBMITTAL REQUIREMENTS**

**A. Respondent Responsibilities:**

Respondents are responsible for any and all costs associated with developing and submitting an RFQ Package in response to this Request for Qualifications. Respondents are also solely responsible for any and all costs associated with interviews and/or presentations requested by the County. It is expressly understood, no Respondent may seek or claim any award and/or re-imbursement from the County for any expenses, costs, and/or fees (including attorneys' fees) borne by any Respondent, during the entire RFQ process. Such expenses, costs, and/or fees (including attorneys' fees) are the sole responsibility of the Respondent.

All RFQ Packages received in response to this Request for Qualifications shall become the property of St. Johns County and will not be returned. In the event of contract award, all documentation produced as part of the contract will become the exclusive property of St. Johns County.

By submitting an RFQ Package, each Respondent certifies that the proposer has fully read and understands any and all instructions in the Request for Qualifications, and has full knowledge of the scope, nature, and quality of work to be performed. All RFQ Packages submitted shall be binding for one hundred twenty (120) consecutive calendar days following the submittal due date.

**B. RFQ Package Submittal Format:**

All RFQ Packages must follow the same format, and shall be evaluated partially based on the Respondent's ability to follow the instructions herein. To receive points from evaluation, the RFQ Package format must sufficiently address and demonstrate all required components, and follow the order of sections described below. The aim of the required format is to simplify the preparation and evaluation of the RFQ Packages.

All RFQ Packages must include the following components:

<u>Section</u>	<u>Topic</u>
1	RFQ Qualification Cover Page
2	Cover Letter
3	Company & Staff Qualifications
4	Related Experience
5	Project Approach & Innovation
6	Quality & Schedule Control
7	Additional Information
8	Administrative Information

**C. RFQ Package Components:**

All of the components outlined below must be included with each copy of the RFQ Package and submitted as follows: one (1) original and five (5) copies on 8 1/2" X 11" pages, numbered, 1 inch margins, typewritten with Times New Roman style and 12 size font. Additionally, all headings, sections and sub-sections shall be identified appropriately. All documentation shall be **exact order and format as shown below**. No exceptions to this format will be accepted. The goal of the required format is to simplify the proposal preparation and evaluation process, and to ensure that all proposals receive the same orderly review. **The Quality of Submittal scoring for proposals will be based on the format, the organization, and the attention to detail.**

**Respondents shall not include the St. Johns County Seal/Logo in any part of their submitted package.** Should a package be submitted with the County's seal/logo included, the County reserves the right to find the submitting firm non-responsive to the requirements stated herein, which may result in the respondent being removed from consideration for award of a contract under this RFQ.

In order to insure a uniform review process and to obtain the maximum degree of comparability, it is required that proposals be organized in the manner specified as follows:

**Section 1: RFQ Qualification Cover Page (Complete and Submit)**

**Section 2: Cover Letter (Limit 1 page)**

Provide a cover letter. Include the original signed cover letter with the original proposal and a copy of the cover letter with each copy of the proposal. The cover letter should provide the following:

- Respondent's name, contact person, business address, phone number, fax number and e-mail address
- A brief statement of the respondent's understanding of the services required.
- Profile - Provide a brief company background statement to include, but not limited to, years in business, company size, corporate structure, types of services offered, and professional affiliations.

**Section 3: Company and Staff Qualifications**

In this section, respondent shall provide evidence that the firm has qualified and experienced staff to perform the scope of services required for this project. In addition, provide a brief summary of the firm's overall capabilities relative to the Engineering Services as outlined in the scope and work relative to this project.

- Provide key personnel assigned to the project, including the project manager, QA/QC personnel and the Design team
- Provide a Project Organization Chart
- Include a one (1) page resume for each key personnel
- Identify the primary contact for this project
- Include a list of sub-consultants with credentials and related experience (Limit to 1 page)
- Proper and valid licensing to conduct business in the State of Florida
- Current Applicable Department of Professional Regulation License(s)
- Current Applicable Certification(s)

**Section 4: Related Experience (Limit 1 page – all 3 projects must be included on this one page)**

In this section, respondent shall provide evidence of successful completion, as the lead firm, of three (3) projects in the past ten (10) years as described in the Project Description. Emphasis should be on projects of comparable size and scope. Photographs

can be submitted to illustrate each project but must be clearly marked with the project name and date.

**Section 5: Project Approach & Innovation** (Limit 4 pages)

In this section, respondent shall provide a narrative describing the proposed approach and innovative practices. Briefly describe the approach the firm intends to take to successfully complete a quality and timely project. In addition, briefly describe any innovative and cost savings achieved for design and permitting of the project. Innovation can include reduction of right of way acquisition costs, faster design and permitting, bid alternates. This section will weigh heavily for scoring purposes. Respondents are encouraged to think outside of normal processes and procedures for delivering the project quicker and less expense to the County.

**Section 6: Quality & Schedule Control** (Limit 2 pages)

In this section, the respondent shall provide a written narrative of the firm's project management methods to establish, monitor and track quality control methods including coordination of sub-consultants, and ability to meet schedules in a timely manner.

**Section 7: Additional Information** (Limit 4 pages)

In this section, at the respondent's discretion, include additional information to support the proposal. However, choose the additional information carefully, because this section of the proposal should not constitute the bulk of the submission. This section may include charts, graphs and photographs.

**Section 8: Administrative Information**

Please include the following:

- Proof of Liability Insurance and its limits
- Drug Free Work Place Form (Complete and Submit)
- RFQ Affidavit (Complete and submit)
- RFQ Affidavit of Solvency (Complete and Submit)
- Acknowledged Addenda



**PART VII: – ATTACHMENTS/FORMS**

**REQUEST FOR QUALIFICATIONS (RFQ) NO: 16-21  
CR 210 Widening - Greenbriar Rd. to Cimarrone Blvd.  
Professional Engineering Services**

**COVER PAGE**

**SUBMIT ONE (1) ORIGINAL AND FIVE (5) COPIES TO:**

**PURCHASING DEPARTMENT  
ST. JOHNS COUNTY  
500 SAN SEBASTIAN VIEW  
ST. AUGUSTINE FLORIDA 32084  
ATTN: Karen Fullerton, Procurement Supervisor**

**COMPANY NAME:** \_\_\_\_\_

**DATE:** \_\_\_\_\_

**REQUEST FOR QUALIFICATIONS (RFQ) NO: 16-21  
CR 210 Widening - Greenbriar Rd. to Cimarrone Blvd.  
Professional Engineering Services**

**Company Name:** \_\_\_\_\_

**St. Johns County Board of County Commissioners  
Drug-Free Workplace Form**

The undersigned firm, in accordance with Florida Statute 287.087 hereby certifies that

\_\_\_\_\_ does:  
Name of Firm

1. Publish a statement notifying employees that the unlawful manufacture, distribution, dispensing, possession or use of a controlled substance is prohibited in the workplace and specifying the actions that will be taken against employees for violations of such prohibition.
2. Inform employees about the danger of drug abuse in the workplace, the business' policy of maintaining a drug-free workplace, any available drug counseling, rehabilitation, employee assistance programs and the penalties that may be imposed upon employees for drug abuse violations.
3. Give each employee engaged in providing the contractual services that are described in St. Johns County's request for proposals to provide bond underwriter services a copy of the statement specified in paragraph 1.
4. In the statement specified in paragraph 1, notify the employees that, as a condition of working on the contractual services described in paragraph 3, the employee will abide by the terms of the statement and will notify the employer of any conviction of, or plea of guilty or nolo contendere to, any violation of Florida Statute 893, as amended, or of any controlled substance law of the United States or any state, for a violation occurring in the workplace no later than five (5) days after such conviction or plea.
5. Impose a sanction on, or require the satisfactory participation in a drug abuse assistance or rehabilitation program if such is available in the employee's community by, any employee who is so convicted.
6. Consistent with applicable provisions with State or Federal law, rule, or regulation, make a good faith effort to continue to maintain a drug-free workplace through implementation of paragraphs 1 through 5.

As the person authorized to sign this statement, I certify that this firm complies fully with the above requirements.

\_\_\_\_\_  
Signature

\_\_\_\_\_  
Date

**REQUEST FOR QUALIFICATIONS (RFQ) NO: 16-21  
CR 210 Widening - Greenbriar Rd. to Cimarrone Blvd.  
Professional Engineering Services**

**AFFIDAVIT**

TO: ST. JOHNS COUNTY BOARD OF COUNTY COMMISSIONERS  
ST. AUGUSTINE, FLORIDA

At the time the proposal is submitted, the Respondent shall attach to his proposal a sworn statement.

The sworn statement shall be an affidavit in the following form, executed by an officer of the firm, association or corporation submitting the proposal and shall be sworn to before a person who is authorized by law to administer oaths.

STATE OF \_\_\_\_\_ COUNTY OF \_\_\_\_\_. Before me, the undersigned authority, personally appeared \_\_\_\_\_ who, being duly sworn, deposes and says he is \_\_\_\_\_ (Title) of \_\_\_\_\_ (Firm) the respondent submitting the attached proposal for the services covered by the RFQ documents for RFQ No: 16-21 CR 210 Widening – Professional Engineering Services.

The affiant further states that no more than one proposal for the above referenced project will be submitted from the individual, his firm or corporation under the same or different name and that such respondent has no financial interest in the firm of another respondent for the same work, that neither he, his firm, association nor corporation has either directly or indirectly entered into any agreement, participated in any collusion, or otherwise taken any action in restraint of free competitive bidding in connection with this firm’s proposal on the above described project. Furthermore, neither the firm nor any of its officers are debarred from participating in public contract lettings in any other state.

\_\_\_\_\_  
(Proposer)

By \_\_\_\_\_

\_\_\_\_\_  
(Title)

STATE OF \_\_\_\_\_)

COUNTY OF \_\_\_\_\_)

Subscribed and sworn to before me this \_\_\_\_\_ day of \_\_\_\_\_, 20\_\_\_\_, by \_\_\_\_\_ who personally appeared before me at the time of notarization, and who is personally known to me or who has produced \_\_\_\_\_ as identification.

\_\_\_\_\_  
Notary Public

My commission expires:  
\_\_\_\_\_

**VENDOR ON ALL COUNTY PROJECTS MUST EXECUTE AND ATTACH THIS AFFIDAVIT TO EACH PROPOSAL.**

**REQUEST FOR QUALIFICATIONS (RFQ) NO: 16-21  
CR 210 Widening - Greenbriar Rd. to Cimarrone Blvd.  
Professional Engineering Services**

**AFFIDAVIT OF SOLVENCY**

PERTAINING TO THE SOLVENCY OF {insert entity name}, being of lawful age and being duly sworn I, {insert affiant name}, as {insert position or title} (ex. CEO, officer, president, duly authorized representative, etc.) hereby certify under penalty of perjury that:

1. I have reviewed and am familiar with the financial status of above stated entity.
2. The above stated entity possesses adequate capital in relation to its business operations or any contemplated or undertaken transaction to timely pay its debts and liabilities (including, but not limited to, unliquidated liabilities, unmatured liabilities and contingent liabilities) as they become absolute and due.
3. The above stated entity has not, nor intends to, incur any debts and/or liabilities beyond its ability to timely pay such debts and/or liabilities as they become due.
4. I fully understand failure to make truthful disclosure of any fact or item of information contained herein may result in denial of the application, revocation of the Certificate of Public Necessity if granted and/or other action authorized by law.

The undersigned has executed this Affidavit of Solvency, in his/her capacity as a duly authorized representative of the above stated entity, and not individually, as of this \_\_\_\_ day of \_\_\_\_\_, 20\_\_.

\_\_\_\_\_  
Signature of Affiant

STATE OF \_\_\_\_\_)

COUNTY OF \_\_\_\_\_)

Subscribed and sworn to before me this \_\_\_\_ day of \_\_\_\_\_, 20\_\_\_\_, by \_\_\_\_\_ who personally appeared before me at the time of notarization, and who is personally known to me or who has produced \_\_\_\_\_ as identification.

\_\_\_\_\_  
Notary Public

My commission expires:  
\_\_\_\_\_

**PART VIII: OPTIONAL CHECKLIST**

**REQUEST FOR QUALIFICATIONS (RFQ) NO: 16-21  
CR 210 Widening - Greenbriar Rd. to Cimarrone Blvd.  
Professional Engineering Services**

<b>SECTION</b>	<b>RFQ PACKAGE COMPONENTS</b>	<b>CHECK BOX</b>	<b>ST. JOHNS COUNTY USE</b>
<b>Section 1</b>	RFQ Qualification Cover Page		
<b>Section 2</b>	Cover Letter		
<b>Section 3</b>	Company & Staff Qualifications (Include the following licenses and certifications, as applicable)		
	Proper and Valid Licensing for conducting business in State of FL		
	Current Department of Regulation License(s)		
	Current Applicable Certification(s)		
<b>Section 4</b>	Related Experience		
<b>Section 5</b>	Project Approach & Innovation		
<b>Section 6</b>	Quality & Schedule Control		
<b>Section 7</b>	Additional Information		
<b>Section 8</b>	Administrative Information (include the following):		
	Proof of Liability Insurance and Limits		
	Drug Free Work Place Form		
	RFQ Affidavit		
	RFQ Affidavit of Solvency		
	Acknowledged Addenda		
	Acknowledged Addenda		

**PART IX: SEALED BID MAILING LABEL**

**REQUEST FOR QUALIFICATIONS (RFQ) NO: 16-21  
CR 210 Widening - Greenbriar Road to Cimarrone Blvd.  
Professional Engineering Services**

**Cut along the outer border and affix this label  
to your sealed bid envelope to identify it as a  
"Sealed RFQ"**

<b>SEALED RFQ • DO NOT OPEN</b>	
SEALED RFQ #:	<b>RFQ 16-21</b>
BID TITLE:	<b>CR 210 Widening – Professional Engineering Services</b>
DUE DATE/TIME:	<b>Thursday February 4, 2016 No Later Than 4:00PM</b>
SUBMITTED BY:	_____ Company Name
	_____ Company Address
	_____ Company Address
DELIVER TO:	St. Johns County Purchasing ATTN: Karen Fullerton 500 San Sebastian View St St. Augustine FL 32084



**END OF DOCUMENT**



## St. Johns County Board of County Commissioners

Purchasing Division

December 17, 2015

### ADDENDUM #1

**To: Prospective Bidders**

**From: St. Johns County Purchasing Department**

**Subject: RFQ No. 16-21 County Road 210 Widening – Greenbriar Rd. to Cimarrone Blvd.**

This Addendum #1 is issued for further bidder's information and is hereby incorporated into the bid documents. Each bidder will ascertain before submitting a proposal that he/she has received all Addenda.

**Please return an original copy of this signed Addendum with proposal to the St. Johns County Purchasing Department, Karen Fullerton, Procurement Supervisor; 500 San Sebastian View; St. Augustine, FL 32084.**

#### Questions:

1. Are the one page resumes restricted to the same margins, font style and font size as the core response? Most firms maintain a library of resumes in their own unique style.

Yes, the resumes are restricted to the same margins, font style and font size as the core response.

2. For the list of Sub-Consultants with Credentials and Related Experience, is this limited to one page per Sub-consultant? One page for all, together with the font and margin restrictions, will be very limiting in content for reviewers.

The maximum page limit per Sub-Consultant is one page.

**RFQ Due Date remains February 4, 2016 at 4:00 P.M.**

**Acknowledgment**

**Sincerely,**

\_\_\_\_\_  
Signature and Date

Karen R. Fullerton  
Procurement Supervisor

\_\_\_\_\_  
Printed Name/Title

\_\_\_\_\_  
Company Name (Print)

**END OF ADDENDUM NO. 1**



## St. Johns County Board of County Commissioners

Purchasing Division

January 19, 2016

### ADDENDUM #2

**To: Prospective Bidders**

**From: St. Johns County Purchasing Department**

**Subject: RFQ No. 16-21 County Road 210 Widening – Greenbriar Rd. to Cimarrone Blvd.**

This Addendum #2 is issued for further bidder's information and is hereby incorporated into the bid documents. Each bidder will ascertain before submitting a proposal that he/she has received all Addenda.

**Please return an original copy of this signed Addendum with proposal to the St. Johns County Purchasing Department, Karen Fullerton, Procurement Supervisor; 500 San Sebastian View; St. Augustine, FL 32084.**

#### Questions:

1. Regarding Section 3; Bullet Item 5 - "Include a list of sub-consultants with credentials and related experience" and considering the statement made at the Pre-Proposal meeting to not provide separate resumes for sub-consultants: For an included subconsultant firm proposed in a primary teaming partner role intended to provide complementary Design task services as part of the overall Design team, we planned to highlight their key personnel skills and experience in a similar fashion as ours by providing respective 1-page resumes. These key personnel would have a primary role in the project Design success and thus provide a full representation to the selection committee members regarding the comprehensive qualifications and experience offered by the proposed overall Design team. This would be limited to primary subconsultant firms proposed to be engaged in the specific Design team tasks; not the typical secondary project support sub-consultants such as survey, environmental/wetlands, geotechnical, etc. Will this be allowed?

If a submitting firm is partnering with another firm with the intent to provide complementary Design task services as part of the overall Design team, which was encouraged at the non-mandatory pre-proposal meeting, then yes, providing a one (1) page resume for the key personnel or core project team members from the partnering firm is acceptable. This acceptance is not intended to allow one (1) page resumes for sub-consultants who provide specialty services, such as survey, environmental/wetlands, geotechnical, structural, traffic, etc.

2. Part III: General Requirements, Bullet B, Heading Environmental, Page 6 – Under this section it states that the ESA shall be performed by a Florida Registered Environmental Engineering Firm. Would a Florida Registered Geologist be acceptable for this task?

The ESA may be performed by a Florida Registered Geologist as long as the proper Professional Liability Insurance is carried. Professional Liability Insurance Requirements for a Florida Registered Geologist are as follows: The

CONTRACTOR shall maintain during the life of the contract, Professional Liability or Errors and Omissions Insurance with minimum limits of \$1,000,000, if applicable.

Clarifications/Information:

1. This project is a developer funded project and will have a longer development time. Potentially, it could be a three to five year time period for design until the beginning of construction.

2. Page 11, RFQ Package Components, Section 3, Company and Staff Qualifications

For clarifications purposes, key personnel are considered the core project team members. Provide one page resumes for each project team member.

Further clarification, in this same section, the Company Qualifications is limited to 4 pages total, not for each of the prime company and/or partnering company.

3. A map was provided at the non-mandatory pre-proposal meeting on January 14, 2016. The map is will be uploaded to Demand Star for all plan holders to access and is included in this Addendum.

**RFQ Due Date remains February 4, 2016 at 4:00 P.M.**

**Acknowledgment**

**Sincerely,**

\_\_\_\_\_  
Signature and Date

Karen R. Fullerton  
Procurement Supervisor

\_\_\_\_\_  
Printed Name/Title

\_\_\_\_\_  
Company Name (Print)

**END OF ADDENDUM NO. 2**

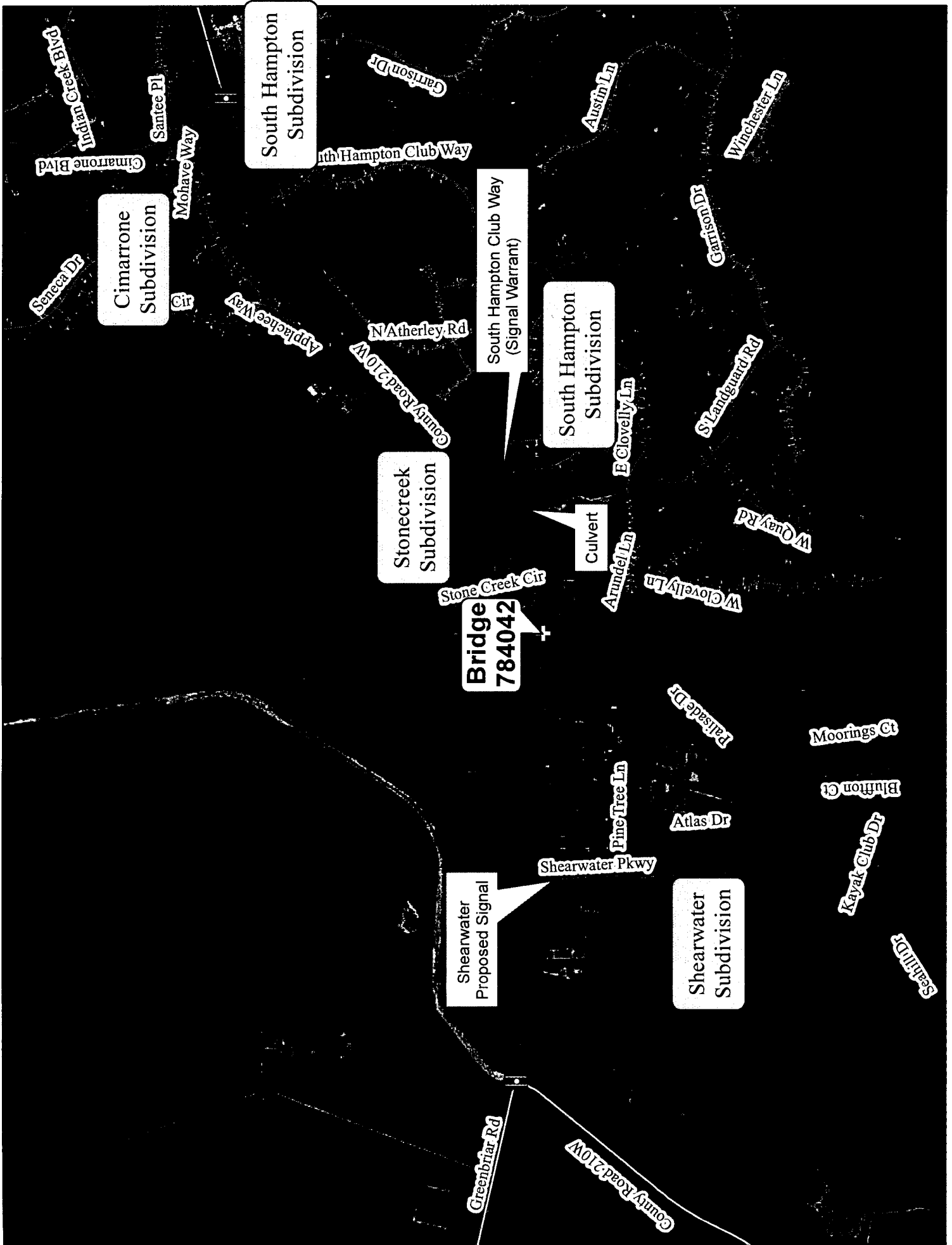

South Hampton Subdivision

Cimarrone Subdivision

Stonecreek Subdivision

South Hampton Subdivision

Shearwater Subdivision

Shearwater Proposed Signal

Bridge 784042

Culvert

South Hampton Club Way (Signal Warrant)

Indian Creek Blvd

Santee Pl

Mohave Way

Cimarrone Blvd

Seneca Dr

South Hampton Club Way

Carlson Dr

Austin Ln

Winchester Ln

Garfield Dr

Appalachee Way

N Atherley Rd

County Road 210W

South Hampton Club Way (Signal Warrant)

E Clovelly Ln

St Landguard Rd

W Quay Rd

Stone Creek Cir

Arundel Ln

W Clovelly Ln

Parsade Dr

Moorings Ct

Bluffton Ct

Atlas Dr

Kayak Club Dr

Pine-free Ln

Shearwater Pkwy

Sailors Dr

Greenbriar Rd

County Road 210W



## St. Johns County Board of County Commissioners

Purchasing Division

January 25, 2016

### ADDENDUM #3

**To: Prospective Bidders**

**From: St. Johns County Purchasing Department**

**Subject: RFQ No. 16-21 County Road 210 Widening – Greenbriar Rd. to Cimarrone Blvd.**

This Addendum #3 is issued for further bidder's information and is hereby incorporated into the bid documents. Each bidder will ascertain before submitting a proposal that he/she has received all Addenda.

**Please return an original copy of this signed Addendum with proposal to the St. Johns County Purchasing Department, Karen Fullerton, Procurement Supervisor; 500 San Sebastian View; St. Augustine, FL 32084.**

Questions:

1. Page 11, RFQ Package Components, Section 3, Company and Staff Qualifications:  
Page #2 of Addendum #2 notes that Company Qualifications is limited to 4 pages total. Does this mean our write-up describing our company and team qualifications is limited to 4 pages, not inclusive of resumes, organizational chart, list of sub-consultants, business licenses and certifications? Or are all of some of these supporting documents to be included in the 4 pages?

The limitation of 4 pages for the Company and Team Qualifications does not include resumes, the organizational chart, list of sub-consultants, business licenses, and certifications.

**RFQ Due Date remains February 4, 2016 at 4:00 P.M.**

**Acknowledgment**

**Sincerely,**

\_\_\_\_\_  
Signature and Date

Karen R. Fullerton  
Procurement Supervisor

\_\_\_\_\_  
Printed Name/Title

\_\_\_\_\_  
Company Name (Print)

**END OF ADDENDUM NO. 3**