

RESOLUTION NO. 2021 - 350

A RESOLUTION BY THE BOARD OF COUNTY COMMISSIONERS OF ST. JOHNS COUNTY, FLORIDA, AUTHORIZING THE COUNTY ADMINISTRATOR, OR DESIGNEE, TO AWARD BID NO. 21-101 AND TO EXECUTE AN AGREEMENT WITH CHINCHOR ELECTRIC INC FOR SIGNALIZATION REPLACEMENT AT INTERSECTION OF US 1 / LEWIS POINT ROAD / ST AUGUSTINE SOUTH DRIVE – HMGP 4283-011-R.

RECITALS

WHEREAS, the County is progressing with the HMGP project to replace the signal at the intersection of US1, Lewis Point Road and St. Augustine South Drive, with the scope of work includes provision of any and all labor, materials, and equipment required in order for replacement of the existing strain pole and span wire signals with mast arms at the intersection of U.S. 1 (SR 5), Lewis Point Road and St. Augustine South Drive, in St. Johns County, Florida, in accordance with Bid No. 21-101; and

WHEREAS, through the County's formal Bid process, Chinchor Electric, Inc. was the lowest, responsive, responsible bidder; and

WHEREAS, the County has reviewed the terms, provisions, conditions and requirements of the proposed contract (attached hereto, an incorporated herein) and finds that entering into contract to complete the work serves a public purpose.

WHEREAS, the contract will be in substantial conformance with the attached draft contract.

NOW, THEREFORE BE IT RESOLVED BY THE BOARD OF COUNTY COMMISSIONERS OF ST. JOHNS COUNTY, FLORIDA, as follows:

Section 1. The above Recitals are incorporated by reference into the body of this Resolution and such Recitals are adopted as finds of fact.

Section 2. The County Administrator, or designee, is hereby authorized to award Bid No. 21-101 to Chinchor Electric, Inc. as the lowest, responsive, responsible bidder.

Section 3. Upon approval by the Board of County Commissioners, the County Administrator, or designee, is further authorized to execute an agreement in substantially the same form and format as the attached draft on behalf of the County to provide the scope of services as specifically provided in Bid No: 21-101.

Section 4. To the extent that there are typographical and/or administrative errors that do not change the tone, tenor, or concept of this Resolution, then this Resolution may be revised without subsequent approval by the Board of County Commissioners.

PASSED AND ADOPTED by the Board of County Commissioners of St. Johns County, Florida, on this 17th day of August, 2021.

BOARD OF COUNTY COMMISSIONERS OF ST. JOHNS COUNTY, FLORIDA

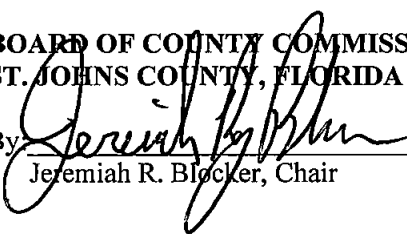
By: 
Jeremiah R. Blocker, Chair

ATTEST: Brandon J. Patty,
Clerk of the Circuit Court & Comptroller

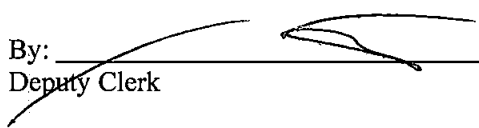
By: 
Deputy Clerk

RENDITION DATE 8/17/21





**STANDARD AGREEMENT
BETWEEN
OWNER AND CONTRACTOR**
(1992 EDITION, REVISED 05/07/20)
Master Contract No: 21-MCS-CHI-14160_

This Contract Agreement (“Agreement”) is made as of _____, 2021 by and between **ST. JOHNS COUNTY, FL** (“Owner”), a political subdivision of the State of Florida, whose principal offices are located at 500 San Sebastian View, St. Augustine, FL 32084, and **CHINCHOR ELECTRIC, INC.** (“Contractor”), with offices located at: 1460 S Leavitt Ave., Orange City, FL 32763, Phone: 386-774-1020, Fax: 386-774-7223, and E-mail: dhasco@chinchorelectric.com, under seal for Construction of **BID NO: 21-101; CONSTRUCTION OF SIGNALIZATION REPLACEMENT AT INTERSECTION OF US 1 / LEWIS POINT ROAD / ST. AUGUSTINE SOUTH DRIVE – HMGP 4283-011-R**, hereinafter referred to as the “Project”.

The Owner and the Contractor hereby agree as follows:

**ARTICLE I
THE CONTRACT AND THE CONTRACT DOCUMENTS**

1.1 The Contract

1.1.1 The Contract between the Owner and the Contractor, of which this Agreement is a part, consists of the Contract Documents. It shall be effective on the date this Agreement is executed by the last party to execute it.

1.2 The Contract Documents

1.2.1 The Contract Documents consist of this Agreement, the Bid Documents and Bid Forms, Specifications, all Change Orders and Field Orders issued hereafter and executed by the parties and the Engineers, any other amendments hereto executed by the parties hereafter, together with the following: Bid Documents, Bonds and Insurance.

Documents not enumerated in this Paragraph 1.2.1 are not Contract Documents and do not form part of this Agreement.

1.2.2 Product Data, Samples and other submittals from the Contractor do not constitute Contract Documents. Their purpose is merely to demonstrate the manner in which the Contractor intends to implement the Work in conformance with the information received from the Contract Documents. All Product Data, Samples and other submittals shall belong to the Owner and shall be delivered, or returned to Owner, as applicable, prior to Submittals shall belong to Owner and shall be delivered, or returned to Owner, as applicable, prior to Substantial Completion.

1.3 Entire Agreement

1.3.1 The Contract, together with the Contractor’s Public Construction Bond for the Project, constitutes the entire and exclusive agreement between the Owner and the Contractor with reference to this Project. Specifically, but without limitation, this Agreement supersedes any Bid Documents not listed among the Contract Documents described above and all prior written or oral communications, representations and negotiations, if any, between the Owner and Contractor.

1.4 No Privity with Others

1.4.1 Nothing contained in this Agreement shall create, or be interpreted to create, privity or any other contractual agreement between the Owner and any person or entity other than the Contractor.

1.5 Intent and Interpretation

1.5.1 The intent of this Agreement is to require complete, correct and timely execution of the Work. Any work that may be required implied or inferred by the Contract Documents, or any one or more of them, as necessary to produce the intended result shall be provided by the Contractor for the Contract Price.

1.5.2 The Contract is intended to be an integral whole and shall be interpreted as internally consistent. What is required by any one Contract Document shall be considered as required by the Contract.

1.5.3 When a word, term or phrase is used in this Agreement, it shall be interpreted or construed, first, as defined herein; second, if not defined, according to its generally accepted meaning in the construction industry; and third, if there is no generally accepted meaning in the construction industry, according to its common and customary usage.

1.5.4 The words "include," "includes" or "including," as used in this Agreement, shall be deemed to be followed by the phrase "without limitation."

1.5.5 The specification herein of any act, failure, refusal, omission, event, occurrence, or condition as constituting a material breach of this Agreement shall not imply that any other, non-specified act, failure, refusal, omission, event, occurrence, or condition shall be deemed not to constitute a material breach of this Agreement.

1.5.6 Words or terms used as nouns in this Agreement shall be inclusive of their singular and plural forms, unless the context of their usage clearly requires a contrary meaning.

1.5.7 The Contractor shall have a continuing duty to read, carefully study and compare each of the Contract Documents, the Shop Drawings and the Product Data and shall give written notice to the Engineer and the Owner of any inconsistency, ambiguity, error or omission which the Contractor may discover with respect to these documents before proceeding with the affected Work. The issuance, or the express or implied approval by the Owner or the Engineer of the Contract Documents, Shop Drawings, or Product Data shall not relieve any such approval by evidence of the Contractor's compliance with the Contract. The Owner has requested the Engineer to only prepare documents for the Project, including the Drawings and Specifications for the Project, which are accurate, adequate, consistent, coordinated, and sufficient for construction. HOWEVER, THE OWNER MAKES NO REPRESENTATION OR WARRANTY OF ANY NATURE WHATSOEVER TO THE CONTRACTOR CONCERNING SUCH DOCUMENTS. By the execution hereof, the Contractor acknowledges and represents that it has received, reviewed and carefully examined such documents, has found them to be complete, accurate, adequate, consistent, coordinated and sufficient for construction, and that the Contractor has not, does not, and shall not rely upon any representation or warranties by the Owner concerning such documents as no such representation or warranties have been or are hereby made.

1.5.8 As between numbers and scaled measurements on the Drawings and in the Design, the numbers shall govern; as between larger scale and smaller scale drawings, the larger scale shall govern.

1.5.9 Neither the organization of any of the Contract Documents into divisions, sections, paragraphs, articles, (or other categories), nor the organization or arrangement of the Design, shall control the Contractor in dividing the Work or in establishing the extent or Scope of Work to be performed by Subcontractors.

1.6 Ownership of Contract Documents

1.6.1 The Contract Documents, and each of them, shall remain the property of the Owner. The Contractor shall have the right to keep one record set of the Contract Documents upon completion of the Project; provided, however, that in no event shall Contractor use, or permit to be used, any or all of such Contract Documents on other projects without Owner's prior written authorization.

ARTICLE II THE WORK

2.1 Scope of Work

The Contractor shall perform all of the Work required, implied, or reasonably inferable from, this Agreement.

2.1.1 The term "Work" shall mean whatever is done by or required of the Contractor to perform and complete its duties under this Agreement, including the following: construction of the whole or a designated part of the Project in the manner set forth in the Contract Documents; furnishing of any required Surety Bonds and insurance; and the provision or furnishing of labor, supervision, services, materials, supplies, equipment, fixtures, appliances, facilities, tools, transportation, storage, power, permits and licenses required of the Contractor, fuel, heat, light, cooling and all other utilities as required by this Agreement. The Work to be performed by the Contractor is generally described as follows:

The Contractor shall be responsible for providing any and all labor, materials, and equipment required for replacement of signalization at the intersection of US 1 (SR 5) and Lewis Point Road/St. Augustine South Drive. This project includes replacing the existing strain pole and span wire signals with mast arms. All existing signal equipment, including the strain poles and span wires, will need to be removed and new signal equipment will need to be installed. This includes the

installation of one mast arm on each corner, for a total of four mast arms. The intersection is to remain fully signalized throughout construction. In addition, this project includes the installation of new pedestrian features on each corner of the intersection. Miscellaneous improvements (lighting, conduit, pull boxes, controller cabinet, vehicle detection, etc.) will also be required.

Funding for this project is through the Hazard Mitigation Grant Program (HMGP) as approved by the Florida Division of Emergency Management (Division) and the Federal Emergency Management Agency (FEMA).

The FEMA project number is HMGP 4283-011-R, funded under FEMA-DR-4283-FL.

All work shall be performed in accordance with the plans and specifications under Bid No. 21-101.

2.2 Cleaning the Site and the Project

2.2.1 The Contractor shall keep the site reasonably clean during performance of the Work. Upon Final Completion of the Work, the Contractor shall clean the site and the Project and remove all waste, together with all of the Contractor's property therefrom.

2.3 Access to Work

2.3.1 The Owner and the Project Director shall have access to the Work at all times from commencement of the Work through Final Completion. The Contractor shall take whatever steps necessary to provide access when requested.

2.4 Safety

2.4.1 The Contractor shall be responsible for supervising all safety precautions, including initiating and maintaining such programs in connection with the performance of the Contract and for adequate maintenance of traffic.

2.4.2 The Contractor shall designate a member of the on-site construction team whose duty shall be the prevention of accidents. Unless notified otherwise in writing by the Contractor to the Owner and the Engineer, this person shall be the Contractor's Superintendent.

ARTICLE III CONTRACT TIME

3.1 Time and Liquidated Damages

3.1.1 The Contractor shall commence the Work within ten (10) days upon receipt of the Notice to Proceed and shall Substantially Complete all Work within **One Hundred Eighty (180)** consecutive calendar days. Final Completion shall be reached by or before **Twenty (20)** consecutive calendar days after Substantial Completion.

The number of calendar days from the date on which the Work is permitted to proceed, through the date set forth for Final Completion, shall constitute the "Contract Time."

3.1.2 The Contractor, prior to commencing the Work, shall submit to the Project Director for his information, the Contractor's schedule for completing the Work. The Contractor's schedule shall be revised no less frequently than monthly (unless the parties otherwise agree in writing) and shall be revised to reflect conditions encountered from time to time and shall be related to the entire Project. In the event any schedule revision impacts the completion time as provided in Section 3.1.1 above, the Contractor shall submit a request for time extension, in accordance with procedures as provided herein. Failure by the Contractor to strictly comply with the provisions of this Paragraph shall constitute a material breach of this Agreement.

3.1.3 The Contractor shall pay the Owner the sum of **\$1,665.00** per day for each and every calendar day of unexcused delay in achieving Substantial Completion beyond the date set forth herein for Substantial Completion of the Work. Any sum's due and payable hereunder by the Contractor shall be payable, not as a penalty, but as liquidated damages representing an estimate of delay damages likely to be sustained by the Owner, estimated at or before the time of executing this Agreement. When the Owner reasonably believes that Substantial Completion shall be inexcusably delayed the Owner shall be entitled, but not required, to withhold from any amounts otherwise due the Contractor an amount then believed by the Owner to be adequate to recover liquidated damages applicable to such delays. If and when the Contractor overcomes the delay in achieving Substantial Completion, or any part thereof, for which the Owner has withheld payment, the Owner

shall promptly release to the Contractor those funds withheld, but no longer applicable, as liquidated damages.

3.2 Substantial Completion

3.2.1 "Substantial Completion" shall mean that stage in the progression of the Work when the Work is sufficiently complete in accordance with this Agreement that the Owner can enjoy beneficial use or occupancy of the Work and can utilize the Work for its intended purpose.

3.3 Time is of the Essence

3.3.1 All limitations of time set forth in the Contract Documents are of the essence of this Agreement.

ARTICLE IV CONTRACT PRICE

4.1 The Contract Price

4.1.1 The Owner shall pay, and the Contractor shall accept, as full and complete payment for all the Work required herein a total Lump Sum price of **Six Hundred Nine Thousand Six Hundred Ninety-Six Dollars and Fifty Cents (\$609,696.50)**.

The sum set forth in the Paragraph 4.1 shall constitute the Contract Price, which shall not be modified except by Change Order as provided in this Agreement.

ARTICLE V PAYMENT OF THE CONTRACT PRICE

5.1 Schedule of Values

5.1.1 Within ten (10) calendar days of the effective date hereof, the Contractor shall submit to the Owner and to the Project Director a Schedule of Values allocating the Contract Price to the various portions of the Work. The Contractor's Schedule of Values shall be prepared in such form, with such detail, and supported by such data as the Project Director or the Owner may require to substantiate its accuracy. The Contractor shall not imbalance its Schedule of Values nor artificially inflate any element thereof. The violation of this provision by the Contractor shall constitute a material breach of this Agreement. The Schedule of Values shall be used only as a basis for the Contractor's Applications for Payment and shall only constitute such basis after it has been agreed upon in writing by the Project Director and the Owner. The Owner may terminate this Agreement without liability of any kind if the Schedule of Values is not agreed upon within fifteen (15) calendar days of the effective date hereof.

5.2 Payment Procedure

5.2.1 The Owner shall pay the Contract Price to the Contractor as provided below.

5.2.2 Progress Payments - On or before the fifteen (15) day of each month after commencement of the Work, the Contractor shall submit an Application for Payment for the period ending the thirtieth (30th) day of the previous month to the Project Director in such form and manner, and with such supporting data and content, as the Project Director may require. Therein, the Contractor may request payment based upon the amount of work done or completed. All partial estimates and payments shall be subject to correction when submitted. Based upon the Contractor's Applications for Payment submitted to the Project Director and upon Certificates for Payment subsequently issued to the Owner by the Project Director, payments will be made in accordance with the Local Government Prompt Payment Act.

5.2.3 The amount of such payments shall be the total value of the Work done to the date of the estimate, based upon the quantities and the Contract unit and/or lump sum prices, less an amount retained and less payments previously made. The amount retained shall be determined in accordance with Section 255.078 of the Florida Statutes:

(a) Owner may withhold from each progress payment made to the Contractor an amount not to exceed five (5) percent of the payment as retainage until completion of the Work.

(b) The Owner shall make prompt payment to the Contractor, unless in accordance with Section 255.078(6) of the Florida Statutes, such funds are the subject of a good faith dispute, claim or demand by the Owner or the Contractor.

5.2.4 Each Application for Payment shall be signed by the Contractor and shall constitute the Contractor's representation that the Work has progressed to the level for which payment is requested that the Work has been properly installed or performed in full accordance with this Agreement, and that the Contractor knows of no reason why payment should not be

made as requested. Thereafter, the Project Director and Engineer shall review the Application for Payment and may also review the Work at the project site or elsewhere to determine whether the quantity and quality of the Work is as represented in the Application for Payment and is as required by this Agreement. The Project Director shall determine and certify to the Owner the amount properly owing to the Contractor. The Owner shall make partial payments on accounts of the Contract Price within thirty (30) days following the Project Director's receipt of each Application for Payment. The amount of each partial payment shall be the amount certified for payment by the Project Director less such amounts, if any, otherwise owing by the Contractor to the Owner or which the Owner shall have the right to withhold as authorized by this Agreement. The Project Director's certification of the Contractor's Application for Payment shall not preclude the Owner from the exercise of any of its rights as set forth in Paragraph 5.3 herein below.

5.2.5 The Contractor warrants that title to all Work covered by an Application shall pass to the Owner no later than time of payment. The Contractor further warrants that upon submittal of an Application for Payment, all Work for which payments have been received from the Owner shall be free and clear of liens, claims, security interest or other encumbrances in favor of the Contractor or any other person or entity whatsoever.

5.2.6 The Contractor shall promptly pay each Subcontractor out of the amount paid to the Contractor on account of such Subcontractor's Work, the amount to which such Subcontractor is entitled. In the event the Owner becomes informed that the Contractor has not paid a Subcontractor as herein provided, the Owner shall have the right, but not the duty, to issue future checks in payment to the Contractor of amounts otherwise due hereunder naming the Contractor and such Subcontractor as joint hereunder naming the Contractor and such Subcontractor as joint payees. Such joint check procedure, if employed by the Owner, shall create no rights in favor of any person or entity beyond the right of the named payees to payment of the check and shall not be deemed to commit the Owner to repeat the procedure in the future.

5.2.7 No progress payment, nor any use or occupancy of the Project by the Owner, shall be interpreted to constitute an acceptance of any Work not in strict accordance with this Agreement.

5.3 Withheld Payment

5.3.1 Owner may decline to make payment, may withhold funds and, if necessary, may demand the return of some or all of the amounts previously paid to the Contractor, to protect the Owner from loss because of:

- a) Defective Work not remedied by the Contractor and, in the opinion of the Owner, not likely to be remedied by the Contractor;
- b) claims of third parties against the Owner or the Owner's property;
- c) Failure by the Contractor to pay Subcontractors or others in a prompt and proper fashion;
- d) Evidence that the balance of the Work cannot be completed in accordance with the Contract for unpaid balance of the Contract Price;
- e) Evidence that the Work shall not be completed in the time required for Substantial or Final Completion;
- f) Persistent failure to carry out the Work in accordance with the Contract;
- g) Damage to the Owner or a third party to whom the Owner is, or may be, liable.

In the event that the Owner makes written demand upon the Contractor for amounts previously paid by the Owner as contemplated in this Subparagraph 5.3.1, the Contractor shall promptly comply with such demand.

5.4 Unexcused Failure to Pay

5.4.1 If within ten (10) days after the date established herein for payment to the Contractor by the Owner, the Owner, without cause or basis hereunder, fails to pay the Contractor any amount due and payable to the Contractor, then the Contractor may after seven (7) additional days, written notice to the Owner and the Project Director, and without prejudice to any other available rights or remedies it may have, stop the Work until payment of those amounts due from the Owner have been received. Any payment not made within ten (10) days after the date due shall bear interest at the rate of 12 percent (12%) per annum.

5.5 Substantial Completion

5.5.1 When the Contractor believes the Work is Substantially Complete, the Contractor shall submit to the Project Director a list of items to be completed or corrected. When the Project Director on the basis of an inspection determines that the Work is in fact Substantially Complete, he shall prepare a Certificate of Substantial Completion which shall establish the date of Substantial Completion, shall state the responsibilities of the Owner and the Contractor for Project security,

maintenance, heat, utilities, damage to the Work, and insurance, and shall fix the time within which the Contractor shall complete the items listed therein. Guarantees required by the Contract shall commence on the date of Substantial Completion of the Work. The Certificate of Substantial Completion shall be submitted to the Owner and the Contractor for their written acceptance of the responsibilities assigned to them in such certificate.

Until Final Completion and acceptance of the Work by the Owner, the Owner shall pay the Contractor an amount equal to ninety percent (90%) of the Contract price. Ten Percent (10%) of the Contract Price shall be retained until Final Completion, acceptance of the Work by the Owner and Final Payment to the Contractor.

5.6 Final Completion and Final Payment

5.6.1 When all the Work is finally complete and the Contractor is ready for a Final Inspection, it shall notify the Owner and the Project Director thereof in writing. Thereupon, the Project Director shall make Final Inspection of the Work and, if the Work is complete in full accordance with this Agreement and this Agreement has been fully performed, the Project Director shall promptly issue a Final Certificate for Payment and if required to repeat its Final Inspection of the Work, the Contractor shall bear the cost of such repetition of the Work, the Contractor shall bear the cost of such repeat Final Inspection(s) which cost may be deducted by the Owner and all other Authorities having jurisdiction under Florida Laws or regulations.

5.6.1.1 If the Contractor fails to achieve Final Completion within the time fixed therefore by the Engineer in its Certificate of Substantial Completion, the Contractor shall pay the Owner liquidated damages at the sum shown in Paragraph 3.1.3. per day for each and every calendar day of unexcused delay in achieving Final Completion beyond the date set forth herein for Final Completion of the Work. Any sum's due and payable hereunder by the Contractor shall be payable, not as penalty, but as liquidated damages representing an estimate of delay damages likely to be sustained by the Owner, estimated at or before the time of executing the Contract. When the Owner reasonably believes that Final Completion shall be inexcusably delayed, the Owner shall be entitled, but not required, to withhold from any amounts otherwise due the Contractor an amount then believed by the Owner to be adequate to recover liquidated damages applicable to such delays. If and when the Contractor overcomes the delay in achieving Final Completion, or any part thereof, for which the Owner has withheld payment, the Owner shall promptly release to the Contractor those funds withheld, but no longer applicable, as liquidated damages.

5.6.2 The Contractor shall not be entitled to Final Payment unless and until it submits to the Project Director its affidavit that all payrolls, invoices for materials and equipment, and other liabilities connected with the Work for which the Owner, or the Owner's property might be responsible, have been fully paid or otherwise satisfied; releases and waivers of claims and lien from all Subcontractors of the Contractor and of any and all other parties required by the Project Director or the Owner; consent of Surety, if any, to Final Payment. If any third party fails or refuses to provide a release of claim or waiver of a lien as required by Owner the Contractor shall furnish a bond satisfactory to the Owner to discharge any such lien or indemnify the Owner from liability.

5.6.3 The Owner shall make Final Payment of all sums, due the Contractor within thirty (30) days of the Project Director's execution of a Final Certificate for Payment.

5.6.4 Acceptance of Final Payment shall constitute a waiver of all claims against the Owner by the Contractor except for those claims previously made in writing against the Owner by the Contractor, pending at the time of Final Payment, and identified in writing by the Contractor as unsettled at the time of its request for Final Payment.

ARTICLE VI THE OWNER

6.1 Information, Services and Things Required from Owner

6.1.1 The Owner shall furnish to the Contractor, at the time of executing this Agreement, any and all written and tangible material in its possession concerning conditions below ground at the site of the Project. Such written and tangible material is furnished to the Contractor only in order to make complete disclosure of such material and for no other purpose. By furnishing such material, the Owner does not represent, warrant, or guarantee its accuracy either in whole, in part, implicitly, or at all, and shall have no liability therefore. The Owner shall also furnish surveys, legal limitations and utility locations (if known), and a legal description of the Project site. Copies may be provided instead of originals.

6.1.2 Excluding permits and fees normally the responsibility of the Contractor, the Owner shall obtain all approvals,

easements, and the like required for construction.

6.1.3 The Owner shall furnish the Contractor, free of charge, 5 copies of the Contract Documents for execution of the Work. The Contractor shall be charged, and shall pay the Owner \$25.00 per additional set of Contract Documents which it may require.

6.2 Right to Stop Work

6.2.1 If the Contractor persistently fails or refuses to perform the Work in accordance with this Agreement, the Owner may order the Contractor to stop the Work, or any described portion thereof, until the cause for stoppage has been corrected, no longer exists, or the Owner orders that Work be resumed. In such event, the Contractor shall immediately obey such order.

6.3 Owner's Right to Perform Work

6.3.1 If the Contractor's Work is stopped by the Owner under Paragraph 6.2, and the Contractor fails within seven (7) days of such stoppage to provide adequate assurance to the Owner that the cause of such stoppage shall be eliminated or corrected, the Owner may, without prejudice to any other rights or remedies the Owner may have against the Contractor, proceed to carry out the subject Work.

In such a situation, an appropriate Change Order shall be issued deducting from the Contract Price the cost of correcting the subject deficiencies, and compensation for the Owner's additional services and expenses necessitated thereby, if any. If the unpaid portion of the Contract Price is insufficient to cover the amount due the Owner, the Contractor shall pay the difference to the Owner.

ARTICLE VII THE CONTRACTOR

7.1 The Contractor is again reminded of its continuing duty set forth in Subparagraph 1.5.7. The Contractor shall perform no part of the Work at any time without adequate Contract Documents or, as appropriate, approved Shop Drawings, Product Data or Samples for such portion of the Work. If the Contractor performs any of the Work where Contractor knows or should know such work involves a recognized error, inconsistency or omission in the Contract Documents without such notice to the Project Director and the Owner, the Contractor shall bear responsibility for such performance and shall bear the cost of correction.

7.2 The Contractor shall perform the Work strictly in accordance with this Agreement.

7.3 The Contractor shall supervise and direct the Work using the Contractor's best skill, effort and attention. The Contractor shall be responsible to the Owner for any and all acts or omissions of the Contractor, its employees and other engaged in the Work on behalf of the Contractor.

7.4 Warranty

7.4.1 The Contractor warrants to the Owner that all labor furnished to progress the Work under this Agreement shall be competent to perform the tasks undertaken, that the product of such labor shall yield only first-class results, that materials and equipment furnished shall be of good quality, free from faults and defects and in strict conformance with this Agreement. This warranty shall survive termination of this Agreement and shall not be affected by Final Payment hereunder. All Work not conforming to these requirements may be considered defective.

7.5 Contractor shall obtain and pay for all permits, fees and licenses necessary and ordinary for the Work. The Contractor shall comply with all lawful requirements applicable to the Work and shall give and maintain any and all notices required by applicable law pertaining to the Work.

7.6 Supervision

7.6.1 The Contractor shall employ and maintain at the Project site only competent supervisory personnel. Absent written instruction from the Contractor to the contrary, the superintendent shall be deemed the Contractor's authorized representative at the site and shall be authorized to receive and accept any and all communications from the Owner or Assignees.

7.6.2 Key supervisory personnel assigned by the Contractor to this Project are as follows:

Name

Function

Name	Function
_____	_____
_____	_____
_____	_____

So long as the individuals named above remain actively employed or retained by the Contractor, they shall perform the functions indicated next to their names unless the Owner agrees to the contrary in writing. In the event one or more individuals not listed above subsequently assume one or more of those functions listed above, the Contractor shall be bound by the provisions of this Subparagraph 7.6.2 as though such individuals have been listed above.

7.7 Indemnity

7.7.1 To the fullest extent permitted by law, the Contractor shall indemnify and hold harmless the Owner, employees and officials from, and against, any, and all, administrative/legal/equitable liability, claims, damages, losses and expenses, including attorneys' fees, arising out of or resulting from performance of the work, noted in either the Scope of Work, or the Contract Documents, that are referenced and considered a part of this Agreement. It is specifically noted that such liability, claims, damages, loss or expense includes any of those referenced instances attributable to bodily injury, sickness, disease, or death, or to injury to, or destruction of, personal and/or real property, including the loss of use resulting therefrom or incident to, connected with, associated with or growing out of direct and/or indirect negligent or intentional acts or omissions by the Contractor, a Subcontractor, or anyone directly, or indirectly employed by them, or anyone for whose acts the Contractor or Subcontractor may be liable, regardless of whether or not such liability, claim, damage, loss or expense is caused in part by a party indemnified hereunder.

7.7.2 In claims against any person or entity indemnified under this Paragraph 7.7.1 by an employee of the Contractor, a Subcontractor, any one directly or indirectly employed by them or anyone for whose acts they may be liable, the indemnification obligation under this Paragraph 7.7.1 shall not be limited by a limitation on amount or type of damages, compensation or benefits payable by or for the Contractor or a Subcontractor under workers' compensation acts, disability benefits acts or other employee benefit acts.

7.8 Employment Eligibility and Mandatory Use of E-Verify.

7.8.1 As a condition precedent to entering into this Agreement, and in accordance with section 448.095, F.S., Contractor and its subcontractors shall register with and use the E-Verify system to verify the work authorization status of all employees hired on or after January 1, 2021.

- a) Contractor shall require each of its subcontractors to provide Contractor with an affidavit stating that the subcontractor does not employ, contract with, or subcontract with an unauthorized alien. Contractor shall maintain a copy of such affidavit for the duration of this Agreement.
- b) The County, Contractor, or any subcontractor who has a good faith belief that a person or entity with which it is contracting has knowingly violated section 448.09(1), F.S. or these provisions regarding employment eligibility shall terminate the contract with the person or entity.
- c) The County, upon good faith belief that a subcontractor knowingly violated these provisions regarding employment eligibility, but Contractor otherwise complied, shall promptly notify Contractor and Contractor shall immediately terminate the contract with the subcontractor.
- d) The County and Contractor hereby acknowledge and mutually agree that, a contract terminated pursuant to these provisions regarding employment eligibility is not a breach of contract and may not be considered as such. Any contract terminated pursuant to these provisions regarding employment eligibility may be challenged in accordance with section 448.095(2)(d), F.S.
- e) Contractor acknowledges that, in the event that the County terminates this Contract for Contractor's breach of these provisions regarding employment eligibility, then Contractor may not be awarded a public contract for at least one

(1) year after such termination. Contractor further acknowledges that Contractor is liable for any additional costs incurred by the County as a result of the County's termination of this Agreement for breach of these provisions regarding employment eligibility.

- f) Contractor shall incorporate in all subcontracts made pursuant to this Agreement the provisions contained herein regarding employment eligibility.

7.9 Contractor Safety and Health Requirements

7.9.1 The Contractor shall be responsible for supervising all safety precautions, including initiating and maintaining such programs in connection with the performance of the Contract and for adequate maintenance of traffic.

7.9.2 The Contractor shall designate a member of the on-site construction team whose duty shall be the prevention of accidents. Unless notified otherwise in writing by the Contractor to the Owner and the Engineer, this person shall be the Contractor's Superintendent.

7.9.3 OSHA Requirements

The Contractor warrants that the product, products, or services supplied to St. Johns County shall conform in all respects to the standards set forth in the Occupational Safety and Health Act (OSHA) of 1970 as amended and the failure to comply will be considered a breach of contract. St. Johns County shall be held harmless against any unsafe conditions and contractor employee incidents.

7.9.4 Compliance with Occupational Safety and Health Act:

Contractor certifies that all material, equipment, services, etc., furnished in this bid meets all OSHA requirements for the applicable Sectors. Bidder further certifies that, if he is the successful bidder, and the material, equipment, service, etc., delivered or provided is subsequently found to be deficient in any OSHA requirement in effect on date of delivery or service fulfillment date, all costs necessary to bring the material, equipment, service, etc., into compliance with the aforementioned requirements shall be borne by the bidder. All Personal Protective Equipment used by the contractor and their employees shall be ANSI certified and meet OSHA standards.

7.9.5 Training and Education:

Contractors will ensure that Contractor employees are trained appropriately for their work tasking. The minimum requirements are found in Federal and State Regulations. Examples of this training are (but not limited to):

- Lockout Tagout
- Fall Protection
- Electrical Safety and the National Electrical Code (NEC)
- Confined Space Entry
- Hot Work
- Specific Chemical Hazards
- Excavations and Trenching
- Heavy Equipment Operation

Special emphasis should be given towards training and compliance with the Construction industry's "Focus Four" established by OSHA as an outreach program to the construction industry and its workers. Training, education, and awareness should be provided in the areas of: 1) Fall Hazards, 2) Caught-In and Between Hazards, 3) Struck-By Hazards, and 4) Electrocutation Hazards.

7.9.6 Fire Extinguishers (For Fire Extinguisher Services)

Pursuant to Florida State Statute Chapter 633 Section 304 and NFPA 1, Florida Fire Prevention Code, fire extinguisher services shall be performed by a contractor who is licensed/permitted by the State Fire Marshal.

7.9.7 Toxic Substances/Federal Hazard Communication "Right To Know and Understand" Regulations

The Federal "Right to Know and Understand" Regulation (also known as the Hazard Communication / Globally Harmonized System of Classification and Labeling of Chemicals (GHS) implemented by OSHA requires employers to inform their employees of any toxic substances to which they may be exposed in the workplace, and to provide training in safe chemical storage, labeling, handling practices and emergency procedures.

Accordingly, the Contractor(s) performing under this contract shall be required to provide two (2) complete sets of Safety Data Sheets (SDS) to each of the departments utilizing the awarded products. This information should be provided at the time when the initial delivery is made, on a department-by-department basis. If performing work on site, it is preferred that each contractor bring their hazardous communication program and SDS in a binder labeled with the contractor's name and identified as a Hazardous Communication/GHS Program. Upon leaving the jobsite and the removal of all hazardous materials, contractors shall take their information with them. The transport, use, and disposal of toxic substances must be conducted in accordance with DEP/EPA regulations.

Upon request, contractors working at St. Johns County facilities or jobsites will be given access to the written Hazardous Communication Program and informed where to locate SDS.

7.9.8 Temporary Traffic Control (TTC)/Maintenance of Traffic (MOT)

The Contractor must comply with the Florida Department of Transportation's (DOT) Temporary Traffic Control (TTC) and the Manual on Uniform Traffic Control Devices (MUTCD) in the planning, development, design, implementation, operation, enforcement and inspection of work zone related transportation management and temporary traffic control on streets and highways within the State Highway System right-of-way. Training in the Advanced, Intermediate, and Flagger categories must be completed by the Contractor for their employees when performing right-of-way work while under contract with St. Johns County. Contractor employees must wear a Class II (daytime), Class III (night/limited visibility) high-visibility safety vest or equivalent high-visibility apparel while performing any work that places them in the right-of-way

ARTICLE VIII CONTRACT ADMINISTRATION

8.1 Project Director

8.1.1 The Project Director, unless otherwise directed by the Owner shall perform those duties and discharge those responsibilities allocated to the Project Director as set forth in this Agreement. The Project Director shall be the Owner's representative from the effective date of this Agreement until Final Payment has been made. The Project Director shall be authorized to act on behalf of the Owner only to the extent provided in this Agreement.

8.1.2 The Owner and the Contractor shall communicate with each other in the first instance through the Project Director.

8.1.3 The Project Director shall be the initial interpreter of the requirements of the drawings and specifications and the judge of the performance there under by the Contractor. The Project Director shall render written or graphic interpretations necessary for the proper execution or progress of the Work with reasonable promptness on request of the Contractor.

8.1.4 The Project Director shall review the Contractor's Applications for Payment and shall certify to the Owner for payment to the Contractor, those amounts then due to the Contractor as provided in this Agreement.

8.1.5 The Project Director shall have authority to reject Work, which is defective or does not conform to the requirements of this Agreement. If the Project Director deems it necessary or advisable, the Project Director shall authority to require additional inspection or testing of the Work for compliance with Contract requirements at Contractor's expense.

8.1.6 The Project Director shall review and approve, or take other appropriate action as necessary, concerning the Contractor's submittals including Product Data and Samples. Such review, approval or other action shall be for the sole purpose of determining conformance with the design concept and information given through the Contract Documents.

8.1.7 The Project Director shall prepare Change Orders and may authorize minor changes in the Work by field order as provided elsewhere herein.

8.1.8 The Project Director shall, upon written request from the Contractor, conduct inspections to determine the date of Substantial Completion and the date of Final Completion, shall receive and forward to the Owner for the Owner's review and records, written warranties and related documents required by this Agreement and shall issue a Final Certificate for Payment upon compliance with the requirements of this Agreement.

8.1.9 The Project Director's decision in matters relating to aesthetic effect shall be final if consistent with the intent of this Agreement.

8.2 Claims by the Contractor

8.2.1 All Contractor claims shall be initiated by written notice and claim to the Project Director. Such written notice and claims must be furnished within seven (7) days after occurrence of the event, or the first appearance of the condition, giving rise to the claim.

8.2.2 Pending final resolution of any claim of the Contractor, the Contractor shall diligently proceed with performance of this Agreement and the Owner shall continue to make payments to the Contractor in accordance with this Agreement. The resolution of any claim under this Paragraph 8.2 shall be reflected by a Change Order executed by the Project Director and the Contractor.

8.2.3 Claims for Concealed and Unknown Conditions - Should concealed and unknown conditions encountered in the performance of the Work (a) below the surface of the ground or (b) in an existing structure be at variance with the conditions indicated by this Agreement, or should unknown conditions of an usual nature differing materially from those ordinarily encountered in the area and generally recognized as inherent in Work of the character provided for in this Agreement, be encountered, wherein the Contract Documents or Standard Construction industry practices have not placed the responsibility of discovering such concealed and unknown conditions upon the Contractor prior to the Contractor submitting his Bid for the Work, the Contract Price shall be equitably adjusted by Change Order upon the written notice and claim by either party made within seven (7) days after the first observance of the condition. As a condition precedent to the Owner having any liability to the Contractor for concealed or unknown conditions, the Contract must give the Project Director written notice of, and an opportunity to observe, the condition prior to disturbing it. The failure by the Contractor to make the written notice and claim as provided in this Subparagraph shall constitute a waiver by the Contractor of any claim arising out of or relating to such concealed or unknown condition.

8.2.4 Claims for Additional Costs - If the Contractor wishes to make a claim for an increase in the Contract Price, as a condition precedent to any liability of the Owner therefore, the Contractor shall give the Project Director written notice of such claim within seven (7) days after the occurrence of the event, or the first appearance of the condition, giving rise to such claim. Such notice shall be given by the Contractor before proceeding to execute any additional or changed Work. The failure by the Contractor to give such notice prior to executing the Work shall constitute a waiver of any claim for additional compensation.

8.2.4.1 In connection with any claim by the Contractor against the Owner for compensation in excess of the Contract Price, any liability of the Owner for the Contractor's costs shall be strictly limited to direct costs incurred by the Contractor and shall in no event include indirect costs or consequential damages of the Contractor.

The Owner shall not be liable to the Contractor for claims of third parties, including Subcontractors, unless and until liability of the Contractor has been established therefore in a court of competent jurisdiction.

8.2.5 Claims for Additional Time - If the Contractor is delayed in progressing any task which at the time of the delay is then critical or which during the delay becomes critical, as the sole result of any act or neglect to act by the Owner or someone acting in the Owner's behalf, or by changes ordered in the Work, unusual delay in transportation, unusually adverse weather conditions not reasonably anticipated, fire or any causes beyond the Contractor's control, then the date for achieving Substantial Completion of the Work shall be extended upon the written notice and claim of the Contractor to the Project Director, for such reasonable time as the Project Director may determine.

Any notice and claims for an extension of time by the Contractor shall be made not more than seven (7) days after the occurrence of the event or the first appearance of the condition giving the rise to the claim and shall set forth in detail the Contractor's basis for requiring additional time in which to complete the Project. In the event the delay to the Contractor is continuing one, only one notice and claim for additional time shall be necessary. If the Contractor fails to make such claim for an extension shall be waived. This paragraph shall not be deemed to waive any damages for delay that are covered by insurance.

8.2.5.1 Delays and Extensions of Time - An extension of Contract Time shall not be given due to weather conditions unless such weather conditions more severe than average have caused a delay. In requesting extension of time for weather conditions; Contractor shall present complete records and such requests shall document how weather conditions delayed progress of Work.

8.3 Field Orders

8.3.1 The Project Director shall have authority to order minor changes in the Work not involving a change in the Contract Price or in Contract Time and not inconsistent with the intent of the Contract. Such changes shall be effected by field order

and shall be binding upon the Contractor. The Contractor shall carry out such field orders promptly.

ARTICLE IX SUBCONTRACTORS

9.1 Definition

9.1.1 A Subcontractor is an entity, which has a direct Contract with the Contractor to perform a portion of the Work.

9.2 Award of Subcontracts

9.2.1 Upon execution of the Contract, the Contractor shall furnish the Project Director, in writing, the names of persons or entities proposed by the Contractor to act as a Subcontractor on the Project. The Project Director shall promptly reply to the Contractor, in writing, stating any objections the Project Director may have to such proposed Subcontractor. The Contractor shall not enter into a Subcontract with a proposed Subcontractor with reference to whom the Project Director has made a timely objection.

9.2.2 All subcontracts shall afford the Contractor rights against the Subcontractor, which correspond to those rights afforded to the Owner by Subparagraph 12.2.1 below.

ARTICLE X CHANGES IN THE WORK

10.1 Changes Permitted

10.1.1 Changes in the Work within the general scope of this Agreement, consisting of additions, deletions, revisions, or any combination thereof, may be ordered without invalidating this Agreement, by Change Order or by Field Order.

10.1.2 Changes in the Work shall be performed under applicable provisions of this Agreement and the Contractor shall proceed promptly with such changes.

10.2 Change Order Defined

10.2.1 Change Order shall mean a written order to the Contractor executed by the Project Director, issued after execution of this Agreement, authorizing and directing a change in the Work or an adjustment in the Contract Price or the Contract Time, or any combination thereof. Only the Change Order may change the Contract Price and the Contract Time.

10.3 Changes in the Contract Price

10.3.1 Any change in the Contract Price resulting from a Change Order shall be determined as follows: (a) by mutual agreement between the Owner and the Contractor as evidenced by (1) the change in the Contract Price being set forth in the Change Order, (2) such change in the Contract Price, together with any conditions or requirements related thereto, being initialed by both parties and (3) the Contractor's execution of the Change Order, or (b) if no mutual agreement occurs between the Owner and the Contractor, then, as provided in Subparagraph 10.3.2 below.

10.3.2 If no mutual agreement occurs between the Owner and the Contractor as contemplated in Subparagraph 10.3.1 above, the change in the Contract Price, if any, shall then be determined by the Project Director on the basis of the reasonable expenditures or savings of those performing, deleting or revising the Work attributable to the change, including, in the case of an increase or decrease in the Contract Price, a reasonable allowance for direct job site overhead and profit. In such case, the Contractor shall present, in such form and with such content as the Owner or the Project Director requires, an itemized accounting of such expenditures or savings shall be limited to the following: reasonable costs of materials, supplies, or equipment including delivery costs, reasonable costs of labor, including social security, old age and unemployment insurance, fringe benefits required by a pre-existing agreement or by custom, and workers' compensation insurance, reasonable costs of premiums for all Bonds and insurance, permit fees, and sales, use or other taxes related to the Work and paid by the Contractor, and reasonable costs of directly attributable to the change. In no event shall any expenditure or savings associated with the Contractor's home office or other non-jobsite overhead expenses be included in any change in the Contract Price. Pending final determination of reasonable expenditures or savings to the Owner, payments on account shall be made to the Contractor on the Owner's Certificate of Payment.

10.3.3 If Unit Prices are provided in the Contract, and if the quantities contemplated are so changed in proposed Change Order that application of such Unit Prices to the quantities of Work proposed shall cause substantial inequity to the Owner or to the Contractor that applicable Unit Prices shall be equitable adjusted.

10.4 Minor Changes

10.4.1 The Project Director shall have authority to order minor changes in the Work not involving a change in the Contract Price or an extension of the Contract Time and not inconsistent with the intent of this Agreement. Such minor changes shall be made by written Field Order, and shall be binding upon the Owner and the Contractor. The Contractor shall promptly carry out such written Field Orders.

10.5 Effect of Executed Change Order

10.5.1 The execution of a Change Order by the Contractor shall constitute conclusive evidence of the Contractor's agreement to the ordered changes in the Work, this Agreement as thus amended, the Contract Price and the Contract Time. The Contractor, by executing the Change Order, waives and forever releases any claim against the Owner for additional time or compensation for matters relating to or arising out or resulting from the Work included within or affected by the executed Change Order.

10.6 Notice to Surety; Consent

10.6.1 The Contractor shall notify and obtain the timely consent and approval of the Contractor's surety with reference to all Change Orders if such notice, consent or approval is required by the Contractor's surety or by law. The Contractor's warranty to the Owner that the surety has been notified of and consents to, such Change Order and the surety shall be conclusively deemed to have been notified of such Change Order and to have expressly consented thereto.

ARTICLE XI UNCOVERING AND CORRECTING WORK

11.1 Uncovering Work

11.1.1 If any of the Work is covered contrary to the Project Director's request or to any provision of this Agreement, it shall, if required by the Project Director, be uncovered for the Project Director's inspection and shall be properly replaced at the Contractor's expense without change in the Contract Time.

11.1.2 If any of the Work is covered in a manner not described in Subparagraph 11.1.1 above, it shall, if required by the Project Director or Owner, be uncovered for the Project Director's inspection. If such Work conforms strictly to this Agreement, costs of uncovering and proper replacement shall by Change Order be charged to the Owner. If such Work does not strictly conform to this Agreement, the Contractor shall pay the costs of uncovering and proper replacement.

11.2 Correcting Work

11.2.1 The Contractor shall immediately proceed to correct Work rejected by the Project Director as defective or failing to conform to this Agreement. The Contractor shall pay all costs and expenses associated with correcting such rejected Work, including any additional testing and inspections, and reimbursement to the Owner for the Project Director's services and expenses made necessary thereby.

11.2.2 If within one (1) year after Substantial Completion of the Work, if any of the Work is found to be defective or not in accordance with this Agreement, the Contractor shall correct it within seven (7) days at the Contractor's expense upon receipt of written notice from the Owner. This obligation shall survive Final Payment by the Owner and termination of this Agreement. With respect to Work first performed and completed after Substantial Completion, this one (1) year obligation to specifically correct defective and nonconforming Work shall be extended by the period of time which elapses between Substantial Completion and completion of the subject Work.

11.2.3 Nothing contained in this Paragraph 11.2 shall establish any period of limitation with respect to other obligations, which the Contractor has under this Agreement. Establishment of the one (1) year time period in Subparagraph 11.2.2 relates only to the duty of the Contractor to specifically correct the Work, and has no relationship to the time which the obligation to comply with the Contract Documents may be sought to be enforced.

11.3 Owner May Accept Defective or Nonconforming Work

11.3.1 If the Owner chooses to accept defective or nonconforming Work, the Owner may do so. In such events, the Contract Price shall be reduced by the greater of (a) the reasonable cost of removing and correcting the defective or nonconforming Work, and (b) the difference between the fair market value of the Project had it not been constructed in such manner as to include defective or nonconforming Work. If the remaining portion of the unpaid Contract Price, if any, is

insufficient to compensate the Owner for its acceptance or defective or nonconforming Work, the Contractor shall, upon written demand from the Owner, pay the Owner such remaining compensation for accepting defective or nonconforming Work.

ARTICLE XII CONTRACT TERMINATION

12.1 Termination by the Contractor

12.1.1 If the Work is stopped for a period of ninety (90) days by an order of any court or as a result of an act of the Government, through no fault of the Contractor or any person or entity working directly or indirectly for the Contractor, the Contractor may, upon ten (10) days written notice to the Owner, terminate performance under this Agreement and recover from the Owner payment for the actual reasonable expenditures of the Contractor (as limited in Subparagraph 10.3.2 above) for all Work executed and for materials, equipment, tools, construction equipment and machinery actually purchased or rented solely for the Work, less any salvage value of any such items.

12.1.2 If the Owner shall persistently or repeatedly fail to perform any material obligation to the Contractor for a period of fifteen (15) days after receiving written notice from the Contractor of its intent to terminate if such failure is not substantially corrected within fifteen (15) days, the Contractor may terminate performance under this Agreement by written notice to the Project Director. In such event, the Contractor shall be entitled to recover from the Owner as though the Owner had terminated the Contractor's performance under this Agreement for convenience pursuant to Subparagraph 12.2.1 hereunder.

12.2 Termination by the Owner

12.2.1 For Convenience

12.2.1.1 The Owner may terminate this Agreement for convenience. In such instance, the Owner shall provide written notice of such termination to the Contractor specifying when termination shall become effective.

12.2.1.2 The Contractor shall incur no further obligations in connection with the Work and the Contractor shall stop Work when such termination becomes effective. The Contractor shall also terminate outstanding orders and subcontracts. The Contractor shall settle liabilities and claims arising out of the termination of subcontracts and orders. The Owner may direct the Contractor to assign the Contractor's right, title and interest under terminated orders or subcontracts to the Owner or its designee.

12.2.1.3 The Contractor shall transfer title and deliver to the Owner such completed or partially completed Work and materials, equipment, parts, fixtures, information and Contract rights as the Contractor has.

12.2.1.4 (a) The Contractor shall submit a termination claim to the Project Director specifying the amounts due because of the termination for convenience together with costs, pricing or other data required by the Project Director. If the Contractor fails to file a termination claim within one (1) year from the effective date of termination, the Owner shall pay the Contractor, an amount derived in accordance with subparagraph (c) below.

(b) The Owner and the Contractor may agree to compensation, if any, due to the Contractor hereunder.

(c) Absent agreement to the amount due to the Contractor, the Owner shall pay the Contractor the following amounts;

(d) Contract prices for labor, materials, equipment, and other services accepted under this Agreement;

(e) Reasonable costs incurred in preparing to perform and in performing a portion of the Work prior to termination and not included in (d) or (e), and in terminating the Contractor's performance, plus a fair and reasonable allowance for overhead and profit thereon (such profit shall not include anticipated profit or consequential damages); provided, however, that if it appears that the Contractor would have not profited or would have sustained a loss if the entire Contract had been completed, no profit shall be allowed or included and the amount of compensation shall be reduced to reflect the anticipated rate of loss, if any;

(f) Reasonable costs of settling and paying claims arising out of the termination of Subcontracts or orders pursuant to Subparagraph 12.2.1.2 of this Paragraph. These costs shall not include amounts paid in

accordance with other provisions hereof.

The total sum to be paid the Contractor under this Subparagraph 12.2.1 shall not exceed the total Contract Price, as properly adjusted, reduced by the amount of payments otherwise made, and shall in no event include duplication of payment.

12.2.2 For Cause

12.2.2.1 If the Contractor persistently or repeatedly refuses or fails to perform the Work in a timely manner, supply enough properly skilled Workers, supervisory personnel or proper equipment or materials, or if it fails to make prompt payment to Subcontractors, or for materials or labor, or persistently disregards laws, ordinances, rules, regulations or orders of any public authority having jurisdiction, or otherwise substantially violates a material provision of this Agreement, then the Owner may, by written notice to the Contractor, without prejudice to any other right or remedy, terminate the employment of the Contractor and take possession of the site and of all materials, equipment, tools, construction equipment and machinery thereon owned by the Contractor and may finish the Work by whatever methods it may deem expedient. In such case, the Contractor shall not be entitled to receive any further payment until the Work is finished.

12.2.2.2 If the unpaid balance of the Contract Price less any liquidated damages due under this Agreement, exceeds the cost of finishing the Work, including compensation for the Project Director's additional services and expenses made necessary thereby, such exceed the unpaid balance, the Contractor shall pay the difference to the Owner. This obligation for payment shall survive the termination of the Contract.

12.2.2.3 In the event the employment of the Contractor is terminated by the Owner for cause pursuant to Subparagraph 12.2.2 and it is subsequently determined by a Court of competent jurisdiction that such termination was without cause, such termination shall thereupon be deemed a Termination for Convenience under Subparagraph 12.2.1 and the provisions of Subparagraph 12.2.1 shall apply.

ARTICLE XIII INSURANCE

13.1 Contractor's Insurance:

The Contractor shall not commence work under this Agreement until he/she has obtained all insurance required under this section and such insurance has been approved by the County. All insurance policies shall be issued by companies authorized to do business under the laws of the State of Florida. The Contractor shall furnish proof of Insurance to the County prior to the commencement of operations. The Certificate(s) shall clearly indicate the Contractor has obtained insurance of the type, amount, and classification as required by contract and that no material change or cancellation of the insurance shall be effective without thirty (30) days prior written notice to the County. **Certificates shall specifically include the County as Additional Insured for all lines of coverage except Workers' Compensation and Professional Liability. A copy of the endorsement must accompany the certificate.** Compliance with the foregoing requirements shall not relieve the Contractor of its liability and obligations under this Agreement.

Certificate Holder Address: St. Johns County, a political subdivision of the State of Florida
500 San Sebastian View
St. Augustine, FL 32084

The Contractor shall maintain during the life of this Agreement, Comprehensive General Liability Insurance with minimum limits of \$1,000,000 per occurrence, \$2,000,000 aggregate, to protect the Contractor from claims for damages for bodily injury, including wrongful death, as well as from claims of property damages which may arise from any operations under this contract, whether such operations be by the Contractor or by anyone directly employed by or contracting with the Contractor.

The Contractor shall maintain Umbrella or Excess Liability Insurance covering workers compensation, commercial general liability and business auto liability with minimum limits of liability of \$1,000,000.

The Contractor shall maintain during the life of this Contract, Comprehensive Automobile Liability Insurance with minimum limits of \$2,000,000 combined single limit for bodily injury and property damage liability to protect the Contractor from claims for damages for bodily injury, including the ownership, use, or maintenance of owned and non-owned automobiles, including rented/hired automobiles whether such operations be by the Contractor or by anyone directly or indirectly employed by a Contractor.

The Contractor shall maintain during the life of this Agreement, adequate Workers' Compensation Insurance in at least such amounts as is required by the law for all of its employees per Florida Statute 440.02.

The Contractor shall maintain during the life of this Agreement, Professional Liability or Errors and Omissions Insurance with minimum limits of \$1,000,000, if applicable.

In the event of unusual circumstances, the County Administrator or his designee may adjust these insurance requirements.

ARTICLE XIV MISCELLANEOUS

14.1 Governing Law & Venue

14.1.1 The Contract shall be governed by the laws of the State of Florida. Venue for any administrative and/or legal action arising under the Contract shall be St. Johns County, Florida.

14.2 Successors and Assigns

14.2.1 The Owner and Contractor bind themselves, their successors, assigns and legal representatives to the other party hereto and to successors, assigns and legal representatives of such other party in respect to covenants, agreements and obligations contained in this Agreement. The Contractor shall not assign this Agreement without written consent of the Owner.

14.3 Surety Bonds

14.3.1 The Contractor shall furnish a separate Public Construction Bond to the Owner. Such Bonds shall set forth a penal sum in an amount not less than the Contract Price. The Bond furnished by the Contractor shall incorporate by reference the terms of this Agreement as fully as though they were set forth verbatim in such Bonds. The Public Construction Bond shall provide that in the event the Contract Price is adjusted by Change Order executed by the Contractor. The Public Construction Bond furnished by the Contractor shall be in form suitable to the Owner and shall be executed by a Surety, or Sureties, reasonably suitable to the Owner.

14.4 Safety of Persons and Property

14.4.1 When existing utility lines shown on the Drawings are to be removed or relocated, the Contractor shall notify the Engineer in ample time for taking measures for prevention of the interruption of any required services prior to the beginning of operations. In the event that the Contractor damages any existing utility lines not shown on the Drawings, the location of which is not known to the Contractor report thereof shall be made immediately to the Engineer.

14.4.2 Locations of existing utility lines shown on the Drawings are based on the best information available to the Engineer, but shall not be considered exact either as to location or number of such lines.

14.4.3 Contractor shall protect utility lines constructed under terms of the agreement and those discovered or shown on Drawings to be existing. Damage occurring to utility lines due to Contractor's operations shall be repaired at no cost to the Owner.

ARTICLE XV EQUAL EMPLOYMENT OPPORTUNITY

15.1 Contractor's Employment Opportunity

15.1.1 The Contractor and all Subcontractors shall not discriminate against any employee or applicant for employment because of race, religion, color, sex, national origin or age.

The Contractor shall take affirmative action to insure that applicants are employed, and that employees are treated during employment without regard to their race, religion, color, sex, national origin or age. Such action shall include, but not be limited to, the following: employment, upgrading, demotion or transfer, recruitment or recruitment advertisement, layoff or termination, rates of pay or other forms of compensation, and selection for training, including apprenticeship. The Contractor agrees to post in conspicuous places, available to employees and applicants for employment, notices setting forth the policies of non-discrimination.

15.1.2 The Contractor and all Subcontractors shall, in all solicitations or advertisements for employees placed by them or

on their behalf, state that all qualified applicants shall receive consideration for employment without regard to race, religion, color, sex, national origin or age.

ARTICLE XVI APPRENTICESHIP LAW REQUIREMENTS

16.1 Apprenticeship Law (Chapter 446, Florida Statutes)

16.1.1 The Contractor shall make a diligent effort to hire for Performance of the Contract a number of apprentices in each occupation which bears to the average number of journeyman in that occupation to be employed in the performance of the Contract, the ratio of at least one (1) apprentice or trainee to every five (5) journeymen.

16.1.2 The Contractor shall, when feasible and except when the number of apprentices or trainees to be hired is fewer than four (4), assure that twenty-five (25) percent of such apprentices or trainees are in their first year of training. Feasibility here involves a consideration of the availability of training opportunities for first year apprentices or trainees, the hazardous nature of the Work for beginning workers, and excessive unemployment of apprentices or trainees in their second or subsequent years of training.

16.1.3 The Contractor, during the performance of the Contract, shall make diligent efforts to employ the number of apprentices or trainees necessary to meet requirements of Subparagraphs a. and b. However, on-the-job training programs shall only be established in non-apprenticable trades or occupations to meet the requirements of this section.

16.1.4 The Contractor agrees to return records of employment, by trade, of the number of apprentices or trainees by first year of training, and the number of journeymen and the wages paid, and hours of work, of such persons on a form as prescribed by the Bureau of Apprenticeship of the Division of Labor at three (3) month intervals. Submission of duplicate copies of forms submitted to the United States Department of Labor shall be sufficient compliance with the provisions of the section.

16.1.5 The Contractor agrees to supply the Bureau of Apprenticeship of the Division of Labor, at three (3) months intervals, a statement describing steps taken toward making diligent effort and containing a breakdown by craft or hours worked and wages paid for first year apprentices or trainees, other apprentices or trainees and journeymen.

16.1.6 The Contractor agrees to insert in any Subcontract under this Agreement the requirements contained in this section. "The term Contractor" as used in such clauses and any Subcontract shall mean the Subcontractor.

16.1.7 Anything herein to the Contrary notwithstanding, Contractor agrees to comply with all of the provisions of Florida Statutes 446 and all regulations prescribed by the Bureau of Apprenticeship of the Division of Labor.

ARTICLE XVII PUBLIC RECORDS

17.1 Public Records

17.1.1 The cost of reproduction, access to, disclosure, non-disclosure, or exemption of records, data, documents, and/or materials, associated with this Agreement shall be subject to the applicable provisions of the Florida Public Records Law (Chapter 119, Florida Statutes), and other applicable State and Federal provisions. Access to such public records, may not be blocked, thwarted, and/or hindered by placing the public records in the possession of a third party, or an unaffiliated party.

17.1.2 In accordance with Florida law, to the extent that Contractor's performance under this Contract constitutes an act on behalf of the County, Contractor shall comply with all requirements of Florida's public records law. Specifically, if Contractor is expressly authorized, and acts on behalf of the County under this Agreement, Contractor shall:

(1) Keep and maintain public records that ordinarily and necessarily would be required by the County in order to perform the Services;

(2) Upon request from the County's custodian of public records, provide the County with a copy of the requested records or allow the records to be inspected or copied within a reasonable time at a cost that does not exceed the cost as provided in Chapter 119, Florida Statutes, or as otherwise provided by law;

(3) Ensure that public records related to this Agreement that are exempt or confidential and exempt from public records disclosure requirements are not disclosed except as authorized by applicable law for the duration of this Agreement and following completion of this Agreement if the Contractor does not transfer the records to the County; and

(4) Upon completion of this Agreement, transfer, at no cost, to the County all public records in possession of the Contractor or keep and maintain public records required by the County to perform the Services.

17.1.3 If the Contractor transfers all public records to the County upon completion of this Agreement, the Contractor shall destroy any duplicate public records that are exempt or confidential and exempt from public records disclosure requirements. If the Contractor keeps and maintains public records upon completion of this Agreement, the Contractor shall meet all applicable requirements for retaining public records. All records stored electronically must be provided to the County, upon request from the County's custodian of public records, in a format that is compatible with the County's information technology systems.

17.1.4 Failure by the Contractor to comply with the requirements of this section shall be grounds for immediate, unilateral termination of this Agreement by the County.

IF THE CONTRACTOR HAS QUESTIONS REGARDING THE APPLICATION OF CHAPTER 119, FLORIDA STATUTES, TO ITS DUTY TO PROVIDE PUBLIC RECORDS RELATING TO THIS AGREEMENT, CONTACT THE CUSTODIAN OF PUBLIC RECORDS AT:

**500 San Sebastian View
St. Augustine, FL 32084
(904) 209-0805
publicrecords@sjcfl.us**

**BID NO: 21-100; CONSTRUCTION OF SIGNALIZATION REPLACEMENT AT INTERSECTION
OF US 1 / LEWIS POINT ROAD / ST. AUGUSTINE SHORE DRIVE – HMGP 4283-011-R
Master Contract No: 21-MCS-CHI-14160**

Owner

St. Johns County, FL (Seal)
(Typed Name)

By: _____
Signature of Authorized Representative

Leigh A. Daniels, CPPB
Printed Name

Purchasing Manager
Title

Date of Execution

Contractor

Chinchor Electric, Inc. (Seal)
(Typed Name)

By: _____
Signature of Authorized Representative

Printed Name & Title

Date of Execution

ATTEST:

**St. Johns County, FL
Clerk of Courts**

By: _____
Deputy Clerk

Date of Execution

Legally Sufficient:

Deputy County Attorney

Date of Execution

**BID NO: 21-100; CONSTRUCTION OF SIGNALIZATION REPLACEMENT AT INTERSECTION
OF US 1 / LEWIS POINT ROAD / ST. AUGUSTINE SHORE DRIVE – HMGP 4283-011-R
Master Contract No: 21-MCS-CHI-14160**

EXHIBIT "A"

**HAZARD MITIGATION GRANT PROGRAM (HMGP)
REQUIRED CONTRACT CLAUSES**

1. Equal Employment Opportunity.

- a. The contractor agrees to comply with the requirements of Chapter 760, Florida Statutes, and with Title VI of the Civil Rights Act of 1964 as amended, Title VIII of the Civil Rights Act of 1968 as amended, Section 104(b) and Section 109 of Title I of the Housing and Community Development Act of 1974 as amended, Section 504 of the Rehabilitation Act of 1973, the Americans with Disabilities Act of 1990, the Age Discrimination Act of 1975, Executive Order 11063, and Executive Order 11246 as amended.
- b. If this contract is in excess of \$10,000 and meets the definition of a "federally assisted construction contract" as provided in 41 C.F.R. § 60-1.3, the following shall apply to the contractor's performance under this contract:
 - i. The contractor will not discriminate against any employee or applicant for employment because of race, color, religion, sex, or national origin. The contractor will take affirmative action to ensure that applicants are employed, and that employees are treated during employment without regard to their race, color, religion, sex, or national origin. Such action shall include, but not be limited to the following: Employment, upgrading, demotion, or transfer; recruitment or recruitment advertising; layoff or termination; rates of pay or other forms of compensation; and selection for training, including apprenticeship. The contractor agrees to post in conspicuous places, available to employees and applicants for employment, notices to be provided setting forth the provisions of this nondiscrimination clause.
 - ii. The contractor will, in all solicitations or advertisements for employees placed by or on behalf of the contractor, state that all qualified applicants will receive considerations for employment without regard to race, color, religion, sex, or national origin.
 - iii. The contractor will not discharge or in any other manner discriminate against any employee or applicant for employment because such employee or applicant has inquired about, discussed, or disclosed the compensation of the employee or applicant or another employee or applicant. This provision shall not apply to instances in which an employee who has access to the compensation information of other employees or applicants as part of such employee's essential job functions discloses the compensation of such other employees or applicants to individuals who do not otherwise have access to such information, unless such disclosure is in response to a formal complaint or charge, in furtherance of an investigation, proceeding, hearing, or action, including an investigation conducted by the employer, or is consistent with the contractor's legal duty to furnish information.
 - iv. The contractor will send to each labor union or representative of workers with which he has a collective bargaining agreement or other contract or understanding, a notice to be provided advising the said labor union or workers' representatives of the contractor's commitments under this section, and shall post copies of the notice in conspicuous places available to employees and applicants for employment.

- v. The contractor will comply with all provisions of Executive Order 11246 of September 24, 1965, and of the rules, regulations, and relevant orders of the Secretary of Labor.
- vi. The contractor will furnish all information and reports required by Executive Order 11246 of September 24, 1965, and by rules, regulations, and orders of the Secretary of Labor, or pursuant thereto, and will permit access to his books, records, and accounts by the administering agency and the Secretary of Labor for purposes of investigation to ascertain compliance with such rules, regulations, and orders.
- vii. In the event of the contractor's noncompliance with the nondiscrimination clauses of this contract or with any of the said rules, regulations, or orders, this contract may be canceled, terminated, or suspended in whole or in part and the contractor may be declared ineligible for further Government contracts or federally assisted construction contracts in accordance with procedures authorized in Executive Order 11246 of September 24, 1965, and such other sanctions as may be imposed and remedies invoked as provided in Executive Order 11246 of September 24, 1965, or by rule, regulation, or order of the Secretary of Labor, or as otherwise provided by law.
- viii. The contractor will include the portion of the sentence immediately preceding paragraph (a) and the provisions of paragraphs (a) through (h) in every subcontract or purchase order unless exempted by rules, regulations, or orders of the Secretary of Labor issued pursuant to section 204 of Executive Order 11246 of September 24, 1965, so that such provisions will be binding upon each subcontractor or vendor. The contractor will take such action with respect to any subcontract or purchase order as the administering agency may direct as a means of enforcing such provisions, including sanctions for noncompliance: Provided, however, that in the event a contractor becomes involved in, or is threatened with, litigation with a subcontractor or vendor as a result of such direction by the administering agency the contractor may request the United States to enter into such litigation to protect the interests of the United States.

For the purposes of this section, "federally assisted construction contract" means any agreement or modification thereof between any applicant and a person for construction work which is paid for in whole or in part with funds obtained from the Government or borrowed on the credit of the Government pursuant to any Federal program involving a grant, contract, loan, insurance, or guarantee, or undertaken pursuant to any Federal program involving such grant, contract, loan, insurance, or guarantee, or any application or modification thereof approved by the Government for a grant, contract, loan, insurance, or guarantee under which the applicant itself participates in the construction work.

For the purposes of this section, "construction work" means the construction, rehabilitation, alteration, conversion, extension, demolition or repair of buildings, highways, or other changes or improvements to real property, including facilities providing utility services. The term also includes the supervision, inspection, and other onsite functions incidental to the actual construction.

2. Compliance with the Davis-Bacon Act

- a. Contractor. The awarded Contractor shall comply with the Davis-Bacon Act (40 U.S.C. 3141-3144, and 3146-3148) as supplemented by Department of Labor regulations (29 CFR Part 5, "Labor Standards Provisions Applicable to Contracts Covering Federally Financed and Assisted Construction"). In accordance with the statute, contractors must be required to pay wages to laborers and mechanics at a rate not less than the prevailing wages specified in a wage determination made by the Secretary of Labor. In addition, contractors must be required to pay wages not less than once a week.

3. Compliance with the Copeland "Anti-Kickback" Act.

- a. Contractor. The contractor shall comply with 18 U.S.C. § 874, 40 U.S.C. § 3145, and the requirements of 29 C.F.R. pt. 3 as may be applicable, which are incorporated by reference into this contract.
- b. Subcontracts. The contractor or subcontractor shall insert in any subcontracts the clause above and such other clauses as FEMA may by appropriate instructions require, and also a clause requiring subcontractors to include these clauses in any lower tier subcontracts. The prime contractor shall be responsible for the compliance by any subcontractor or lower tier subcontractor with all of these contract clauses.
- c. Breach. A breach of the contract clauses in subsections (a) and (b) above may be grounds for termination of the contract, and for debarment as a contractor and subcontractor as provided in 29 C.F.R. § 5.12.

3. Contract Work Hours and Safety Standards Act.

- a. This section applies to all contracts in excess of \$100,000 that involve the employment of mechanics or laborers as provided in 40 U.S.C. § 3701.
- b. As provided in 40 U.S.C. § 3702, and as supplemented by Department of Labor regulations (29 C.F.R. Part 5), the contractor shall compute the wages of every mechanic and laborer on the basis of a standard work week of 40 hours. Work in excess of the standard work week is permissible provided that the worker is compensated at a rate of not less than one and a half times the basic rate of pay for all hours worked in excess of 40 hours in the work week.
- c. The requirements of 40 U.S.C. § 3704, as supplemented by 29 C.F.R. Part 5, shall apply to construction work and provide that no laborer or mechanic must be required to work in surroundings or under working conditions which are unsanitary, hazardous or dangerous. These requirements do not apply to the purchases of supplies or materials or articles ordinarily available on the open market, or contracts for transportation or transmission of intelligence.
- d. No contractor or subcontractor contracting for any part of the contract work which may require or involve the employment of laborers or mechanics shall require or permit any such laborer or mechanic in any workweek in which he or she is employed on such work to work in excess of forty hours in such workweek unless such laborer or mechanic receives compensation at a rate not less than one and one-half times the basic rate of pay for all hours worked in excess of forty hours in such workweek.
- e. In the event of any violation of the clause set forth in paragraph (d) of this section the contractor and any subcontractor responsible therefor shall be liable for the unpaid wages. In addition, such contractor and subcontractor shall be liable to the United States (in the case of work done under contract for the District of Columbia or a territory, to such District or to such territory), for liquidated damages. Such liquidated damages shall be computed with respect to each individual laborer or mechanic, including watchmen and guards, employed in violation of the clause set forth in paragraph (d) of this section, in the sum of \$10 for each calendar day on which such individual was required or permitted to work in excess of the standard workweek of forty hours without payment of the overtime wages required by the clause set forth in paragraph (d) of this section.
- f. The County shall upon its own action or upon written request of an authorized representative of the Department of Labor withhold or cause to be withheld, from any moneys payable on account of work performed by the contractor or subcontractor under any such contract or any other Federal contract with the same prime contractor, or any other federally-assisted contract subject to the Contract Work Hours and Safety Standards Act, which is held by the same prime contractor, such sums as may be determined to be necessary to satisfy any liabilities of such contractor or subcontractor for unpaid wages and liquidated damages as provided in the clause set forth in paragraph (e) of this section.
- g. The contractor or subcontractor shall insert in any subcontracts the clauses set forth in paragraph (c) through (f) of this section and also a clause requiring the subcontractors to include these clauses in any lower tier subcontracts. The prime contractor shall be responsible for compliance by any subcontractor or lower tier

subcontractor with the clauses set forth in paragraphs (c) through (f) of this section.

4. Rights to Inventions Made Under a Contract or Agreement

(a) If the Federal award meets the definition of "funding agreement" under 37 CFR §401.2 (a) and the recipient or sub-recipient wishes to enter into a contract with a small business firm or nonprofit organization regarding the substitution of parties, assignment or performance of experimental, developmental, or research work under that "funding agreement," the recipient or sub-recipient must comply with the requirements of 37 CFR Part 401, "Rights to Inventions Made by Nonprofit Organizations and Small Business Firms Under Government Grants, Contracts and Cooperative Agreements," and any implementing regulations issued by the awarding agency.

5. Compliance With Clean Air Act.

- a. The contractor agrees to comply with all applicable standards, orders or regulations issued pursuant to the Clean Air Act, as amended, 42 U.S.C. § 7401 et seq.
- b. The contractor agrees to report each violation to the County and understands and agrees that the County will, in turn, report each violation as required to assure notification to the state of Florida, Federal Emergency Management Agency, and the appropriate Environmental Protection Agency Regional Office.
- c. The contractor agrees to include these requirements in each subcontract exceeding \$100,000 financed in whole or in part with Federal assistance provided through Hazard Mitigation Grant Program funds.

6. Compliance with Federal Water Pollution Control Act.

- a. The contractor agrees to comply with all applicable standards, orders or regulations issued pursuant to the Federal Water Pollution Control Act, as amended, 33 U.S.C. 1251 et seq.
- b. The contractor agrees to report each violation to the County and understands and agrees that the County will, in turn, report each violation as required to assure notification to the state of Florida, Federal Emergency Management Agency, and the appropriate Environmental Protection Agency Regional Office.
- c. The contractor agrees to include these requirements in each subcontract exceeding \$100,000 financed in whole or in part with Federal assistance provided through Hazard Mitigation Grant Program funds.

7. Debarment and Suspension.

- a. This contract is a covered transaction for purposes of 2 C.F.R. Part 180 and 2 C.F.R. Part 3000. As such the contractor is required to verify that none of the contractor, its principals (defined at 2 C.F.R. § 180.995), or its affiliates (defined at 2 C.F.R. § 180.905) are excluded (defined at 2 C.F.R. § 180.940) or disqualified (defined at 2 C.F.R. § 180.935).
- b. The contractor must comply with 2 C.F.R. Part 180, Subpart C and 2 C.F.R. Part 3000, Subpart C and must include a requirement to comply with these regulations in any lower tier covered transaction it enters into.
- c. This certification is a material representation of fact relied upon by the County. If it is later determined that the contractor did not comply with 2 C.F.R. Part 180, Subpart C and 2 C.F.R. Part 3000, Subpart C, in addition to remedies available to the state of Florida and the County, the Federal Government may pursue available remedies, including but not limited to suspension and/or debarment.
- d. The bidder or proposer agrees to comply with the requirements of 2 C.F.R. Part 180, Subpart C and 2 C.F.R. Part 3000, Subpart C while this offer is valid and throughout the period of any contract that may arise from this offer. The bidder or proposer further agrees to include a provision requiring such compliance in its lower tier covered transactions.

8. Byrd Anti-Lobbying Amendment.

Contractors who apply or bid for an award of \$100,000 or more shall file the required certification. Each tier certifies to the tier above that it will not and has not used Federal appropriated funds to pay any person or organization for

influencing or attempting to influence an officer or employee of any agency, a member of Congress, officer or employee of Congress, or an employee of a member of Congress in connection with obtaining any Federal contract, grant, or any other award covered by 31 U.S.C. § 1352. Each tier shall also disclose any lobbying with non-Federal funds that takes place in connection with obtaining any Federal award. Such disclosures are forwarded from tier to tier up to the recipient.

APPENDIX A, 44 C.F.R. PART 18: CERTIFICATION REGARDING LOBBYING

Certification for Contracts, Grants, Loans, and Cooperative Agreements (To be submitted with each bid or offer exceeding \$100,000)

The undersigned [Contractor] certifies, to the best of his or her knowledge, that:

1. No Federal appropriated funds have been paid or will be paid, by or on behalf of the undersigned, to any person for influencing or attempting to influence an officer or employee of an agency, a Member of Congress, an officer or employee of Congress, or an employee of a Member of Congress in connection with the awarding of any Federal contract, the making of any Federal grant, the making of any Federal loan, the entering into of any cooperative agreement, and the extension, continuation, renewal, amendment, or modification of any Federal contract, grant, loan, or cooperative agreement.
2. If any funds other than Federal appropriated funds have been paid or will be paid to any person for influencing or attempting to influence an officer or employee of any agency, a Member of Congress, an officer or employee of Congress, or an employee of a Member of Congress in connection with this Federal contract, grant, loan, or cooperative agreement, the undersigned shall complete and submit Standard Form- LLL, "Disclosure Form to Report Lobbying," in accordance with its instructions.
3. The undersigned shall require that the language of this certification be included in the award documents for all subawards at all tiers (including subcontracts, subgrants, and contracts under grants, loans, and cooperative agreements) and that all subrecipients shall certify and disclose accordingly.

This certification is a material representation of fact upon which reliance was placed when this transaction was made or entered into. Submission of this certification is a prerequisite for making or entering into this transaction imposed by 31 U.S.C. § 1352 (as amended by the Lobbying Disclosure Act of 1995). Any person who fails to file the required certification shall be subject to a civil penalty of not less than \$10,000 and not more than \$100,000 for each such failure.

The Contractor certifies or affirms the truthfulness and accuracy of each statement of its certification and disclosure, if any. In addition, the Contractor understands and agrees that the provisions of 31 U.S.C. § 3801 et seq., apply to this certification and disclosure, if any.

Signature of Contractor's Authorized Official

Name and Title of Contractor's Authorized Official

Date

9. Procurement of Recovered Materials.

- a. In the performance of this contract, the contractor shall comply with Section 6002 of the Solid Waste Disposal Act, as amended by the Resource Recovery Act. The contractor shall make maximum use of products containing recovered materials that are EPA- designated items, as set forth in 40 C.F.R. Part 247, Subpart B, unless the product cannot be acquired—
 - i. Competitively within a timeframe providing for compliance with the contract performance schedule;

- ii. Meeting contract performance requirements; or
- iii. At a reasonable price.

b. The requirements of this section apply to the purchase or acquisition of any procurement item where the purchase price of the item exceeds \$10,000 or where the quantity of such item or of any functionally equivalent item purchased or acquired in the course of the previous fiscal year is \$10,000 or more.

10. Access to Records.

- a. The contractor agrees to provide the County, the FEMA Administrator, the Comptroller General of the United States, or any of their authorized representatives access to any books, documents, papers, and records of the contractor which are directly pertinent to this contract for the purpose of making audits, examinations, excerpts, and transcriptions.
- b. The contractor agrees to permit any of the foregoing parties to reproduce by any means whatsoever or to copy excerpts and transcriptions as reasonably needed.
- c. The contractor agrees to provide the FEMA Administrator or his authorized representatives access to construction or other work sites pertaining to the work being completed under the contract.

11. DHS Seal, Logo, and Flags.

The contractor shall not use the Department of Homeland Security (DHS) seal(s), logos, crests, or reproductions of flags or likenesses of DHS agency officials without specific FEMA pre-approval.

12. Compliance with Federal Law, Regulations, and Executive Orders.

This is an acknowledgement that this contract is funded entirely or in part by Hazard Mitigation Grant Program funds. The contractor will comply with all applicable federal law, regulations, executive orders, and FEMA policies, procedures, and directives, including, but not limited to:

- a. The Robert T. Stafford Disaster Relief and Emergency Management Act;
- b. 44 CFR Parts 7, 9, 10, 13, 14, 17, 18, 25, 206, 220, and 221, and any other applicable FEMA policy memoranda and guidance documents;
- c. State of Florida Administrative Plan for the Hazard Mitigation Grant Program;
- d. Hazard Mitigation Assistance Guidance – February 27, 2015 Update; and
- e. All applicable laws and regulations delineated in Attachment C of the Federally-Funded Subaward and Grant Agreement between St. Johns County and the Florida Division of Emergency Management (Agreement No. H0025)

13. No Obligation by Federal Government.

The Federal Government is not a party to this contract and is not subject to any obligations or liabilities to the non-Federal entity, contractor, or any other party pertaining to any matter resulting from the contract.

14. Fraud and False or Fraudulent or Related Acts.

The contractor acknowledges that 31 U.S.C. Chap. 38 (Administrative Remedies for False Claims and Statements) applies to the contractor's actions pertaining to this contract.

BID NO: 21-100; CONSTRUCTION OF SIGNALIZATION REPLACEMENT AT INTERSECTION
OF US 1 / LEWIS POINT ROAD / ST. AUGUSTINE SHORE DRIVE – HMGP 4283-011-R
Master Contract No: 21-MCS-CHI-14160

EXHIBIT "B"

BID NO: 21-101

ATTACHMENT "M"

(Complete and Submit Attachment "M" for Prime Bidder and each proposed Sub-Contractor)

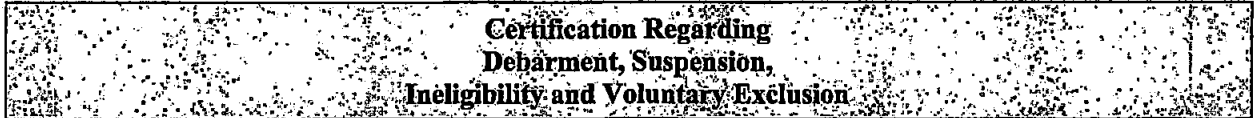

Subcontractor Covered Transactions

- (1) The prospective subcontractor, Chinchor Electric, Inc. of the Sub-Recipient certifies, by submission of this document, that neither it nor its principals is presently debarred, suspended, proposed for debarment, declared ineligible or voluntarily excluded from participation in this transaction by any Federal department or agency.
- (2) Where the Sub-Recipient's subcontractor is unable to certify to the above statement, the prospective contractor shall attach an explanation to this form.

SUBCONTRACTOR:

Chinchor Electric, Inc.

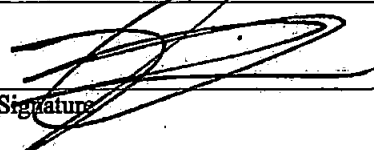
By 
Signature

Timothy I. Chinchor, President
Name and Title

1460 S Leavitt Ave
Street Address

Orange City, FL 32763
City, State, Zip

7/21/2021
Date

St. Johns County BOCC
Sub-Recipient's Name

H0013
Division Contract Number

#4283-011-R
HMGP Project Number

**BID NO: 21-100; CONSTRUCTION OF SIGNALIZATION REPLACEMENT AT INTERSECTION
OF US 1 / LEWIS POINT ROAD / ST. AUGUSTINE SHORE DRIVE – HMGP 4283-011-R
Master Contract No: 21-MCS-CHI-14160**

EXHIBIT "C"

SCHEDULE OF VALUES

The following unit prices, if approved by the Owner, will be used for adjusting the Contract Price for changes in the work (additions or deletions) in accordance with the provisions of an approved change order and any other modifications of the Contract. Unit prices shall include all labor, materials, equipment, transportation, supervision, insurance cost, bond cost, overhead and profit representing an in-place price for each item. Scope or size of each item not otherwise indicated is as described in the construction specifications and drawings.

Signalization Component

Item	Description	Total Quantity	Unit	Unit Price	Total Amount
630-2-11	CONDUIT (F&I) (OPEN TRENCH)	195	LF	\$ 13.92	\$ 2,714.40
630-2-12	CONDUIT (F&I) (DIRECTIONAL BORE)	430	LF	\$ 22.04	\$ 9,477.20
632-7-1	SIGNAL CABLE (F&I) (NEW OR RECONSTRUCTED INTERSECTION)	1	PI	\$ 7,482.00	\$ 7,482.00
632-7-6	SIGNAL CABLE (REMOVE-INTERSECTION)	1	PI	\$ 480.24	\$ 480.24
633-2-32	FIBER OPTIC CONNECTION (INSTALL) (TERMINATION)	12	EA	\$ 49.88	\$ 598.56
633-3-14	FIBER OPTIC CONNECTION HARDWARE (F&I) (BUFFER TUBE FAN-OUT KIT)	1	EA	\$ 87.00	\$ 87.00
633-3-16	FIBER OPTIC CONNECTION HARDWARE (F&I) (PATCH PANEL- FIELD TERMINATED)	1	EA	\$ 2,030.00	\$ 2,030.00
635-2-11	PULL & SPLICE BOX (F&I) (13 "x 24 " COVER SIZE)	13	EA	\$ 828.24	\$ 10,767.12
635-2-12	PULL & SPLICE BOX (F&I) (24 "x 36 " COVER SIZE)	1	EA	\$ 1,452.32	\$ 1,452.32
639-1-122	ELECTRICAL POWER SERVICE (F&I) (UNDERGROUND) (PURCHASED)	1	AS	\$ 3,288.60	\$ 3,288.60
639-2-1	ELECTRICAL SERVICE WIRE (F&I)	130	LF	\$ 4.20	\$ 546.00
641-2-12	PRESTRESSED CONCRETE POLE (F&I) (TYPE P- II SERVICE POLE)	1	EA	\$ 624.08	\$ 624.08
641-2-60	PRESTRESSED CONCRETE POLE (COMPLETE POLE REMOVAL- PEDESTAL/ SERVICE POLE)	1	EA	\$ 80.04	\$ 80.04
641-2-70	PRESTRESSED CONCRETE POLE (SHALLOW POLE REMOVAL- POLE 30 ' AND GREATER)	4	EA	\$ 5,521.60	\$ 22,086.40
646-1-11	ALUMINUM SIGNALS POLE (F&I) (PEDESTAL)	7	EA	\$ 1,838.60	\$ 12,870.20
649-21-10	STEEL MAST ARM ASSEMBLY (F&I) (SINGLE ARM 60 ')	1	EA	\$ 37,560.80	\$ 37,560.80
649-21-15	STEEL MAST ARM ASSEMBLY (F&I) (SINGLE ARM 70 ')	2	EA	\$ 43,360.80	\$ 86,721.60
649-21-21	STEEL MAST ARM ASSEMBLY (F&I) (SINGLE ARM 78 ')	1	EA	\$ 54,148.80	\$ 54,148.80

Pay Item	Description	Total Quantity	Unit	Unit Price	Total Amount
650 - 1- 14	VEHICULAR TRAFFIC SIGNAL (F&I - ALUMINUM) (3 SECTION) (1 WAY)	9	AS	\$ 936.12	\$ 8,425.08
650 - 1- 16	VEHICULAR TRAFFIC SIGNAL (F&I - ALUMINUM) (4 SECTION) (1 WAY)	4	AS	\$ 1,224.96	\$ 4,899.84
653 - 1- 11	PEDESTRIAN SIGNAL (F&I LED COUNTDOWN) (1 WAY)	6	AS	\$ 624.08	\$ 3,744.48
653 - 1- 12	PEDESTRIAN SIGNAL (F&I LED COUNTDOWN) (2 WAYS)	1	AS	\$ 1,226.12	\$ 1,226.12
660-4-11	VEHICLE DETECTION SYSTEM-VIDEO (F&I) (CABINET EQUIPMENT)	1	EA	\$ 31,960.32	\$ 31,960.32
660-4-12	VEHICLE DETECTION SYSTEM-VIDEO (F&I) (ABOVE GROUND EQUIPMENT)	4	EA	\$ 4,120.32	\$ 16,481.28
665 - 1- 11	PEDESTRIAN DETECTOR (F&I) (STANDARD)	8	EA	\$ 236.64	\$ 1,893.12
670 - 5- 111	TRAFFIC CONTROLLER ASSEMBLY (F&I) (NEMA) (1 PRE-EMPTION PLAN)	1	AS	\$ 23,669.80	\$ 23,669.80
670 - 5- 600	TRAFFIC CONTROLLER ASSEMBLY (REMOVE CONTROLLER AND CABINET)	1	AS	\$ 640.32	\$ 640.32
682 - 1- 133	ITS CCTV CAMERA (F&I) (DOME PTZ ENCLOSURE, NON-PRESSURIZED) (IP, HIGH DEFINITION)	1	EA	\$ 7,308.00	\$ 7,308.00
684 - 1- 1	MANAGED FIELD ETHERNET SWITCH (F&I)	1	EA	\$ 1,566.00	\$ 1,566.00
684 - 6- 11	WIRELESS COMMUNICATION DEVICE (F&I) (ETHERNET ACCESS POINT)	2	EA	\$ 1,096.20	\$ 2,192.40
685 - 1- 11	UNINTERRUPTIBLE POWER SUPPLY (F&I) (LINE INTERACTIVE)	1	EA	\$ 5,584.24	\$ 5,584.24
700 - 3- 201	SIGN PANEL (F&I OVERHEAD MOUNT) (UP TO 12 SF)	7	EA	\$ 704.12	\$ 4,928.84
700 - 5- 21	INTERNALLY ILLUMINATED SIGN (F&I OVERHEAD MOUNT) (UP TO 12 SF)	2	EA	\$ 2,800.24	\$ 5,600.48
700 - 5- 22	INTERNALLY ILLUMINATED SIGN (F&I OVERHEAD MOUNT) (12 TO 18 SF)	2	EA	\$ 3,380.24	\$ 6,760.48
Signalization Component Total:					\$ 379,896.16

Roadway Component

Pay Item	Description	Total Quantity	Unit	Unit Price	Total Amount
700 - 1- 11	SINGLE POST SIGN (F&I GROUND MOUNT) (UP TO 12 SF)	1	AS	\$ 755.16	\$ 755.16
711 - 11 - 160	THERMOPLASTIC PAVEMENT MARKINGS (STANDARD) (WHITE) (MESSAGE OR SYMBOL)	2	EA	\$ 174.00	\$ 348.00
711 - 11 - 170	THERMOPLASTIC PAVEMENT MARKINGS (STANDARD) (WHITE) (ARROW)	1	EA	\$ 116.00	\$ 116.00
711 - 14 - 123	THERMOPLASTIC PAVEMENT MARKINGS (PREFORMED) (WHITE) (SOLID) (12 " FOR CROSSWALK)	799	LF	\$ 8.12	\$ 6,487.88
711 - 14 - 125	THERMOPLASTIC PAVEMENT MARKINGS (PREFORMED) (WHITE) (SOLID) (24 " FOR CROSSWALK)	684	LF	\$ 15.66	\$ 10,711.44
711 - 17	THERMOPLASTIC (REMOVE EXISTING THERMOPLASTIC PAVEMENT MARKINGS)	800	SF	\$ 4.64	\$ 3,712.00
Roadway Component Total:					\$ 22,130.48

Pay Item	Description	Total Quantity	Unit	Unit Price	Total Amount
----------	-------------	----------------	------	------------	--------------

Lighting Component

Pay Item	Description	Total Quantity	Unit	Unit Price	Total Amount
630 - 2- 11	CONDUIT (F&I) (OPEN TRENCH)	50.00	LF	\$ 13.92	\$ 696.00
630 - 2- 12	CONDUIT (F&I) (DIRECTIONAL BORE)	280.00	LF	\$ 22.04	\$ 6,171.20
635 - 2- 11	PULL & SPLICE BOX (F&I) (13 "x 24 " COVER SIZE)	6	EA	\$ 828.24	\$ 4,969.44
715 - 1- 12	LIGHTING CONDUCTORS (F&I) (ISULATED) (NO. 8 - 6)	2,982.00	LF	\$ 1.40	\$ 4,174.80
715 - 4- 13	LIGHT POLE COMPLETE (F&I STANDARD POLE STANDARD FOUNDATION) (40' MOUNTING HEIGHT)	3	EA	\$ 5,748.96	\$ 17,246.88
715 - 4- 31	LIGHT POLE COMPLETE (F&I UTI LI TY CONFLICT POLE) (INDEX 175 15 / 715 - 002 FOUNDATION) (30' MOUNTING HEIGHT)	1	EA	\$ 6,212.96	\$ 6,212.96
715 - 4- 70	LIGHT POLE COMPLETE (REMOVE POLE AND FOUNDATION)	2	EA	\$ 1,440.72	\$ 2,881.44
715 - 5- 32	LUMINAIRE & BRACKET ARM (F&I NEW LUMINAIRE AND ARM ON NEW/ EXISTING POLE) (GALVANIZED STEEL)	4	EA	\$ 1,292.24	\$ 5,168.96
715 - 500 - 1	POLE CABLE DISTRIBUTION SYSTEM (F&I) (CONVENTIONAL)	4	EA	\$ 519.68	\$ 2,078.72
Lighting Component Total					\$ 49,600.40

Project Components Subtotal					\$ 451,627.04
------------------------------------	--	--	--	--	----------------------

Non-Bid Component

Pay Item	Description	Total Quantity	Unit	Unit Price	Total Amount
101 - 1	MOBI LIZ ATI ON	10.00	%		\$ 45,162.70
102 - 1	MAI NTENANCE OF TRAFFI C	15.00	%		\$ 67,744.06
	CONTI NGENCY	10.00	%		\$ 45,162.70
Non-Bid Component Total					158,069.46

**BID NO: 21-100; CONSTRUCTION OF SIGNALIZATION REPLACEMENT AT INTERSECTION
OF US 1 / LEWIS POINT ROAD / ST. AUGUSTINE SHORE DRIVE – HMGP 4283-011-R
Master Contract No: 21-MCS-CHI-14160**

EXHIBIT "D"

SCOPE OF WORK

PURPOSE:

The purpose of this Bid is for replacement of signalization at the intersection of US 1 (SR 5) and Lewis Point Road/St. Augustine South Drive in St. Johns County, Florida.

Funding for this project is through the Hazard Mitigation Grant Program (HMGP) as approved by the Florida Division of Emergency Management (Division) and the Federal Emergency Management Agency (FEMA).

The FEMA project number is HMGP4283-011-R, funded under FEMA-DR-4283-FL.

SCOPE OF WORK:

The Contractor shall be responsible for providing any and all labor, materials, and equipment required for replacement of signalization at the intersection of US 1 (SR 5) and Lewis Point Road/St. Augustine South Drive. This project includes replacing the existing strain pole and span wire signals with mast arms. All existing signal equipment, including the strain poles and span wires, will need to be removed and new signal equipment will need to be installed. This includes the installation of one mast arm on each corner, for a total of four mast arms. The intersection is to remain fully signalized throughout construction. In addition, this project includes the installation of new pedestrian features on each corner of the intersection. Miscellaneous improvements (lighting, conduit, pull boxes, controller cabinet, vehicle detection, etc.) will also be required.

General Notes

1. The Florida Department of Transportation standard plans and specifications (latest edition) shall be made a part of the plans and contract documents.
2. St. Johns County shall be informed any time the Contractor is on the job site performing construction should St. Johns County wish to have an inspector on the site. Contact Traffic Operations at (904) 209-0170.
3. The Contractor shall notify St. Johns County Traffic Operations at least 24 hours in advance of installing ground rods, installing underground conduit, setting poles, installing signal head assemblies, or cutting loops.
4. No polycarbonate housing or mounting hardware shall be permitted.
5. All signal heads shall be black aluminum.
6. At the time of final project inspection, the Contractor shall furnish two complete sets of signed and sealed "as-built" plans and complete documentation of any equipment and or hardware used for construction.
7. All conduit shall be 2-inch minimum, except electrical power service duct.
8. The Contractor shall verify color codes for signal cable with St. Johns County Traffic Operations prior to ordering cable.
9. St. Johns County retains the right to either accept or refuse removed equipment. If St. Johns County elects to refuse removed equipment, the Contractor will be responsible for all work and costs associated with the removal and disposal of equipment. All removed equipment that is being turned over to St. Johns County shall be delivered to a designated location set by St. Johns County.

10. One spare conduit shall be stubbed and capped in each of the pull boxes that has conduit to the cabinet.
11. Existing signalization shall remain in place to the extent possible and shall be used for maintenance of traffic, as required. Any maintenance of the existing signals (until removed) shall remain the responsibility of the Contractor.
12. Lane closures will not be permitted on weekends or holidays, nor will they be permitted during the hours of 7:00am to 11:00pm. St. Johns County and/or FDOT Traffic Operations may adjust these times to reflect actual field conditions.
13. When a lane closure is used, an off-duty law enforcement officer shall direct traffic at the Contractor's expense. Off-duty law enforcement officers can be obtained from the office of the St. Johns County sheriff by contacting communications at (904) 810-6671.
14. Two manual pushbutton cords, two keys for the cabinet and two keys for the police panel door shall be furnished.
15. Unless specified otherwise, all pull box covers to be furnished and installed shall be non-metallic and shall include the recessed logo "TRAFFIC SIGNALS". All fiber optic pull boxes shall be oversized to: 3 foot by 2.5 foot by 2 foot deep.
16. Detection, signal cable, interconnect, and electrical service wire shall be run in separate conduit and pull boxes.
17. The Contractor shall maintain the actuated operation of the signalized intersection throughout the life of the contract. Planned detection disruptions are not allowed. Any unplanned disruption to the vehicular detection system at signalized intersections shall be re-actuated within 24 hours. This will be at the Contractor expense.
18. St. Johns County Traffic Operations will approve any power service connections prior to installation and connection. If a service processing fee is required the fee shall be included as part of payment for electrical power service assembly by the Contractor and shall be responsible for the balance of the fee.
19. If a power meter is required the meter base shall be installed per FDOT Standard Plans Index 639-002 figure B or figure D and meet the FDOT Standard Specifications for Road and Bridge Construction 639 not attached to the signal poles or cabinet. The Contractor shall also use and install any equipment that meets the local utilities requirements.
20. All field wiring shall be neatly bundled and clearly identified with permanently legible, weatherproof tags that are securely attached to each cable. The tagging system proposed shall be submitted for approval by St. Johns County Traffic Operations.
21. Any equipment used for construction shall be submitted to St. Johns County Traffic Operations and the Engineer of Record for approval prior to ordering.
22. The Contractor shall be responsible for hand excavating to a depth of 5 feet each pole location to expose existing underground utilities and for coordinating with all utility companies prior to ordering the shop drawing for the mast arms. The Contractor should anticipate up to three excavations per location that may be required. The cost for hand excavating and temporarily backfilling the proposed foundation locations (prior to foundation construction) shall be included in the price for the mast arms.
23. The Contractor shall contact local utility companies to determine the location of underground utilities.
24. The Contractor installing mast arms shall not drill or otherwise modify mast arm bases or matching plates in order to "make it fit" without the Engineer of Record, FDOT (if a state roadway), St. Johns County, and the manufacturer's approval in writing. Each reserves the right to deny the modification for any reason. It is the Contractor's responsibility to ensure the drilled shaft foundation, the mast arm and the mast arm base are built correctly.
25. All signal and pedestrian indications shall have L.E.D. displays. Pedestrian indications shall have a count down

timer.

26. A green colored No. 6 AWG insulated stranded copper wire shall be connected between each of the intersection metal mast arm and pedestrian pole ground rod connection points and then to the controller ground bus. This wire shall be pulled in the same conduit as the signal cable.
27. Each pole and mast arm shall be identified with a permanent 1-inch high engraved or impressed mark which contains all required identification information.
28. Once the signal heads are installed, the Contractor shall bag each head. The proposed bagging material shall be durable and designed for long-term application. No plastic garbage bags or tape shall be used.
29. The Contractor shall ensure all equipment installed is compatible with St. Johns County's existing equipment and software per site.
30. A No. 14 AWG insulated stranded copper wire shall be pulled in the same conduit as the fiber optic cable. Pull box to pull box and not into the cabinet.
31. The traffic signal heads shall be mounted vertical.
32. The Contractor shall use a Florida registered and FDOT prequalified geotechnical engineering firm for testing and QA/QC including but not limited to drilled shaft inspection with cross sonic logging, concrete slump and temperature.
33. The Contractor shall notify the Engineer of Quality Control testing locations and times at least one business day prior. The Contractor shall provide the Engineer and FDOT a copy of test results and reports within one business day of receipt.
34. The Contractor shall have a FDOT certified temporary traffic control specialist during mot setup, breakdown and daily maintenance. The Contractor shall notify the Engineer and FDOT of any required lane closures at least one week prior.
35. The Contractor shall provide a staging area for all materials. No materials or equipment shall be stored within the right-of-way.
36. All excavators are required to contact the sunshine state one call of Florida, phone number 1 (800) 432-4770 or 811 a minimum of two working days (excluding weekends) in advance of commencement of excavation to ensure facilities are located accurately.
37. Conduct all locations and excavations in accordance with the Florida Statute 556 of the underground facilities damage prevention & safety act and all local city and county ordinances that may apply.
38. All areas of disturbed existing or proposed city, county, or state right-of-way shall be sodded.
39. The Engineer of Record shall be given forty-eight hours (48 hours) notice of all meetings and or testing measures related to said project.
40. Existing utilities shown are located according to the information available to the Engineer at the time and have not been independently verified by the Owner or Engineer. Guarantee is not made that all existing underground utilities are shown or that the location of those shown are entirely accurate. Finding the actual location of any existing utilities is the Contractor's responsibility and shall be done before he/she commences any work in the vicinity. Furthermore, the Contractor shall be fully responsible for any and all damages due to the Contractor's failure to exactly locate and preserve any and all underground utilities. The Owner or Engineer will assume no liability for any damages sustained or cost incurred because of the operations in the vicinity of existing utilities or structures, nor for temporary bracing and shoring of same.

41. The Contractor is responsible for any damage to existing utilities, survey monuments, markers, corners, and existing features in the area. Any damage shall be replaced/repared by the Contractor at no additional expense to the owner.
42. The Contractor shall be responsible for traffic signal head alignment and location for interim mot and final inspections. St. Johns County nor FDOT shall be charged to adjust the heads as required.
43. Removal of pavement markings shall not significantly alter the pavement texture.
44. The Contractor shall have a certified IMSA roadway lighting technician and traffic signal construction technician on site overseeing the signal installation.
45. The Contractor shall schedule an inspection with FDOT at 90% completion of construction.
46. All associated equipment shall be compatible with the St. Johns County Traffic Management Center's Trafficware ATMS.now central software.
47. The Contractor shall keep one crosswalk open in each direction, at all times, in order to maintain pedestrian access.
48. Prior to performing work within the US 1 (SR 5) right-of-way, the Contractor shall notify FDOT employee Christopher Pogue at (904) 825-5086

Pay Item Notes

- Pay Item 641-2-70: Shall include the cost to restore the damaged sidewalk from the removal of existing concrete strain poles.
- Pay items 660-4-11 and 660-4-12: Camera V1 shall be Gridsmart Smartmount Kit with Camera (GS-3-SMK). Cameras V2 and V6 shall be Gridsmart Advanced Camera Fiber (GS-3-SMA-F). Contact Cubic at 904-613-9331 to arrange for order and installation.
- Pay Item 670-5-111: Shall be Trafficware Group Wired Cabinet Assembly TS-2 size 6 cabinet with Trafficware Group TS-2 Type 2 Model 981-A1100 controller with Ethernet.
- The existing concrete base shall be reused. The existing conduits for electric, 12 mm fiber optic cable, loop detection, and fire station preemption shall be retained. There is no available slack in the existing 12 mmfo or preemption. The loop detection will not be wired to the new controller but will be left intact for future accessibility. New conduits for signal cable, lighting, and wireless magnetometer detection shall be drilled into open space in existing concrete base.
- Pay Item 684-1-1: Shall be ITS Express 8040 switch.
- Pay Item 684-6-11: Shall be Ubiquiti Networks Nano Station M Model NSM5.
- Pay Item 685-1-11: Shall be temple model FXM 2000. System shall be installed and housed in a separate cabinet from the traffic controller cabinet assembly.

Directional Bore Notes

1. When performing a horizontal directional drilling (HDD) operation, the utility/agency owner (UAO) shall restrict the bored diameter to the maximum diameter allowed for the diameter of the utility being installed. The utility diameter is the casing diameter when casing is used. For utility diameters less than eight (8) inches, the maximum bored diameter is equal to the utility diameter plus four (4) inches. For utility diameters of eight (8) inches to twenty-four (24) inches, the maximum bored diameter is equal to one and one half (1.5) times the utility diameter. For utility diameters greater than twenty-four (24) inches, the maximum bored diameter is equal to the utility diameter

plus one (1) foot. Where a utility has restrained joints the maximum bored diameter shall be the manufacturer's recommended diameter. Additionally, the UAO should maintain a clearance, from any existing vitrified clay sanitary pipe line or existing gas lines, of at least three and one half (3.5) times the bored diameter.

2. When boring under roadway pavement, the UAO shall maintain a bore depth of at least ten (10) times the bored diameter or 30 inches, whichever is greater, as measured from the top of pavement to the top of the bore. The UAO may reduce this depth by determining the water table anticipated at time of installation or a confining layer. The confining layer is a two (2) feet thick layer of earth that resists thirty (30) blows per foot of a standard penetration test. If either of these is determined, the bore depth may be reduced to two (2) feet below the top of the confining layer to the top of the bore, or two (2) feet below the top of the water table to the top of the bore. Additionally, the UAO should maintain a clearance, from any existing vitrified clay sanitary pipe line or existing gas lines, of at least three and one half (3.5) times the bored diameter.
3. The UAO shall also do all of the following:
 - 1) Determine orientation and tracking of the drill bit.
 - 2) Utilize relief holes as necessary to relieve excess pressure down hole.
 - 3) Prevent heaving during pull back.
 - 4) Keep the drill pipe in the bore hole until the final product is pulled into place.
 - 5) When boring under roadway pavement, install the product into a bore hole within the same day that the pre-bore is completed

Utility Notes

1. The location(s) of the utilities shown in the plans (including those designated Vv, Vh, and Vvh) are based on limited investigation techniques and should be considered approximate only. The verified locations/elevations apply only at the points shown. Interpolations between these points have not been verified.
2. All FPL overhead electrical facilities to remain energized and in place. Table a minimum clearance distances specified in Subpart CC of OSHA Rule 29 CFR Part 1926 (as they pertain to crane/derrick operations), and/or those minimum distances specified in 29 CFR 1910.333(c)(3) for work in proximity to power lines not covered by Subpart CC, must be maintained. The Contractor shall coordinate with FPL and Engineer of Record to confirm minimum clearance distances from overhead electric facilities.
3. Utility agency owners per dig ticket:

FPL Electric	(800) 468-8243
Centurylink.	(352) 303-2430
Teco Gas	(813) 228-1351
AT&T Comm.	(561) 997-0240
St. Johns County Water & Sewer	(904) 209-2701
Uniti Fiber	(904) 718-8152

St. Johns County Traffic Signal and ITS Equipment Preferences

1. The traffic signal contract shall provide all interconnectivity with the County ATMS.now software.
2. All associated equipment shall be compatible with our Traffic Management Center's Trafficware ATMS.now central software and include the following:
 - Trafficware Group Wired Cabinet Assembly TS-2 Size 6 cabinet with Trafficware Group Controller-NEMA TS2 to include rear access door.
 - Trafficware Group TS2 Type 2 Model 981-A1100 controller with Ethernet.
 - Trafficware Group Malfunction Management Unit Type 16 Model MMU-516L.
 - Uninterruptable Power Source (UPS) shall be a Temple Uninterruptible Power Supply Model FXM 2000. System shall be installed housed in a separate cabinet from the traffic controller cabinet assembly.
 - Fiber optic Ethernet switch shall be ITS Express Managed Field Ethernet Switch Model 8040.
 - Design should include a camera for monitoring of the intersection: Bosch VG5 Autodome with Ethernet

connection.

3. LED internally illuminated street name signs.
4. Mast Arm assemblies shall have a galvanized finish.
5. Pedestrian assemblies installed with transformer base and aluminum pole.
6. Design should include LED luminaries on the mast arm (Autobahn Series ATBL).

The following items on the Approved Products List are requested to be included in the installation:

- **Trafficware Group, Malfunction Management Unit Type 16**
Supplier: **Trafficware Group, Inc.**
 - Model Number: MMU-516L
 - APL Certification Number: 678-016-007
 - Comment: Note: Re-evaluated new firmware v2.05 with Flashing Yellow Arrow Operation
- **Trafficware Group, Controller - NEMA TS2 Type 2**
Supplier: **Trafficware Group, Inc.**
 - Model Number: 981-A1100
 - APL Certification Number: 671-017-003
 - Comment: (NAZTEC)
- **Trafficware Group, Wired Cabinet Assembly TS-2 Size 6**
Supplier: **Trafficware Group, Inc.**
 - Model Number: 70006-TS2/FL
 - APL Certification Number: 676-023-004
 - Comment: Note: Reviewed and Approved Automatic Transfer Switch and Generator Connection on May 25, 2006. || Reviewed and approved Automatic Transfer Switch and Generator Connection on 5-25-2006 || Reviewed and approved updated printed circuit modules, solid state relays, LED lighting and nylon rollers on 8-15-2014
- **ITS Express, Managed Field Ethernet Switch**
Supplier: **ITS Express**
 - Model Number: ITS Express 80XX Series
 - APL Certification Number: 684-002-007
 - Comment: (Models included in series: ITS-8040, ITS-8012, and ITS-8020+) (Model Tested: ITS-8040 with Firmware Version 1.17) (includes old certification #:78461201219013)
- **Bosch Security Systems, Camera - Dome**
Supplier: **Bosch Security Systems, Inc.**
 - Model Number: VG5-ITS Autodome Series
 - APL Certification Number: 682-002-004
 - Comment: 5/5/2015 update: Model tested: VG5-ITS720P-30X4; Firmware Version: 5.92.0090, Includes old certification #:78260400219013



St. Johns County Board of County Commissioners

Purchasing Division

NOTICE OF INTENT TO AWARD

July 22, 2021

RE: Bid No: 21-101; Signalization Replacement at Intersection of US 1 / Lewis Point Road / St. Augustine South Drive – HMGP 4283-011-R

Please be advised that the Purchasing Department of the St. Johns County is issuing this notice of its Intent to Award a contract to Chinchor Electric, Inc. as the lowest responsive, responsible bidder for Bid No: 21-101; Signalization Replacement at Intersection of US 1 / Lewis Point Road / St. Augustine South Drive – HMGP 4283-011-R. This notice will remain posted until 4:00 PM, Wednesday, July 27, 2021.

Any person (including any bidder or proposer) who is, or claims to be, adversely affected by the County's decision or proposed decision shall file a written Notice of Protest with the Purchasing Department of St. Johns County within 72 hours after the posting of the notice of decision or proposed decision. Failure to file a Notice of Protest within the time prescribed in Section 304.10 of the St. Johns County Purchasing Manual (the Bid Protest Procedure), or failure to post the bond or other security required by the County within the time allowed for filing a bond, shall constitute a waiver of proceedings and a waiver of the right to protest. The protest procedures may be obtained from the Purchasing Department and are included in the County's Purchasing Manual. All of the terms and conditions of the County Purchasing Manual are incorporated herein by reference and are fully binding.

Should the Purchasing Department receive no protests in response to this notice, an agenda item will be submitted to the St. Johns County Board of County Commissioners for their consideration and subsequent approval to award a contract.

Please forward all correspondence, requests or inquiries directly to Diana M. Fye, AS, CPPB, Procurement Coordinator at dfye@sjcfl.us.

Sincerely,

St. Johns County

Board of County Commissioners

County Representative Signature

Date: 7/22/21

Leigh A. Daniels, CPPB
Purchasing Manager
(904) 209-0154 – Direct
(904) 209-0155 – Fax
ldaniels@sjcfl.us



**ST. JOHNS COUNTY
PURCHASING DEPARTMENT**

500 San Sebastian View
St. Augustine, Florida 32084

I N T E R O F F I C E M E M O R A N D U M

TO: Nick Perpich, Project manager
FROM: Diana M. Fye, AS, CPPB, Procurement Coordinator
SUBJECT: Bid # 21-101; Signalization Replacement at Intersection of US 1 / Lewis Point Road
/ St. Augustine South Drive – HMGP 4283-011-R
DATE: July 22, 2021

Attached are copies of the bid proposals received for the above mentioned along with a copy of the Bid Tabulation Sheet.

Please review, evaluate and make a written recommendation for this project. Also, indicate the budgeted amount for this item along with the appropriate charge code and return at your earliest convenience. We will prepare the agenda item and contract.

Please let me know if I can assist your department in any other way.

Dept. Approval Nick Perpich
Date 7/22/21
Budget Amount \$623,480.00
Account Funding Title IMPACT FEE ZONE "C" / FEDERAL GRANT EXP.
IMPACT FEE ZONE "C" / STATE GRANT EXP.
Funding Charge Code 1191-55304-3041-56301 \$457,272.38
1191-55305-3041-56301 \$152,424.12
Award to Chinchor Electric Inc.
Award Amount \$669,696.50

ST JOHNS COUNTY
JUL 22 '21
PURCHASING

**ST. JOHNS COUNTY
BID TABULATION**

BID TITLE SIGNALIZATION REPLACEMENT AT INTERSECTION OF ANY BIDDER AFFECTED ADVERSELY BY AN INTENDED
US 1 / LEWIS POINT ROAD / ST. AUGUSTINE SOUTH DRIVE DECISION WITH RESPECT TO THE AWARD OF ANY BID,
- HMGP 4283-011-R SHALL FILE WITH THE PURCHASING DEPARTMENT FOR
BID NUMBER 21-101 ST. JOHNS COUNTY, A WRITTEN NOTICE OF INTENT
OPENING DATE/TIME July 21, 2021 2:00 PM FILE A PROTEST NOT LATER THAN SEVENTY-TWO (72)
HOURS (EXCLUDING SATURDAY, SUNDAY AND LEGAL
POSTING DATE/TIME FROM 07/22/21 UNTIL 07/27/21 HOLIDAYS) AFTER THE POSTING OF THE BID TABULATION
10:00 AM 10:00 AM PROTEST PROCEDURES MAY BE OBTAINED IN THE
PURCHASING DEPARTMENT.

OPENED BY
TABULATED BY
VERIFIED BY

DIANA M FYE *DF*
APRIL BACON *AB*
[Signature]

BIDDERS	TOTAL LUMP SUM BID						
Chinchor Electric, Inc.	\$609,696.50						
Traffic Control Devices, LLC	\$681,186.00						
Traffic Engineering and Management	\$824,993.10						

BID AWARD DATE - _____

BID NO: 21-101

**OFFICIAL COUNTY BID FORM
ST. JOHNS COUNTY, FLORIDA**

PROJECT: SIGNALIZATION REPLACEMENT AT INTERSECTION OF US 1 / LEWIS POINT ROAD / ST. AUGUSTINE SOUTH DRIVE – HMGP 4283-011-R

TO: THE BOARD OF COUNTY COMMISSIONERS OF ST. JOHNS COUNTY, FLORIDA

DATE SUBMITTED: 7/21/2021

BID PROPOSAL OF

Chinchor Electric, Inc.

Full Legal Company Name

1460 S Leavitt Ave, Orange City, FL 32763

386-774-1020

386-774-7223

Mailing Address

Telephone Number

Fax Number

Bidders: Having become familiar with requirements of the project, and having carefully examined the Bidding Documents and Specifications entitled for Bid No: 21-101; Signalization Replacement at Intersection of US 1 / Lewis Point Road / St. Augustine South Drive – HMGP 4283-011-R in St. Johns County, Florida, the undersigned proposes to furnish all materials, labor and equipment, supervision and all other requirements necessary to comply with the Contract Documents to submit the following Bid Proposal summarized as follows:

TOTAL LUMP SUM BID PRICE: (As per plans and specifications)

\$ 609,696.50

Total Lump Sum Bid Price (Numerical)

six hundred nine thousand six hundred ninety-six and five tenths

/100 Dollars

Total Lump Sum Bid Price (Amount written or typed in words)

Bidder shall insert the Total Lump Sum Bid Price in numerals and in words. Any discrepancy between the two submitted amounts shall be determined by the amount written in words.

The Total Lump Sum Bid Price offered in this Bid Proposal must remain firm for a period of ninety (90) days from the Bid opening date.

BID NO: 21-101

During the preparation of the Bid, the following addenda, if any, were received:

No.: _____ Date Received:

No.: _____ Date Received:

No.: _____ Date Received:

We, the undersigned, hereby declare that no person or persons, firm or corporation, other than the undersigned are interested, in this proposal, as principals, and that this proposal is made without collusion with any person, firm or corporation, and we have carefully and to our satisfaction examined the Bid Documents and Project Specifications.

We have made a full examination of the location of the proposed work and the sources of supply of materials, and we hereby agree to furnish all necessary labor, equipment and materials, fully understanding that any quantities shown therewith are approximate only, and that we will fully complete all requirements therein as prepared by the Owner, within the same time limit specified in the Bid Documents as indicated above.

If the Undersigned is notified of the acceptance of this Bid Proposal by the Board within ninety (90) calendar days for the time set for the opening of Bids, the Undersigned further agrees, to execute a contract for the above work within ten (10) days after notice that his Bid has been accepted for the above stated compensation in the form of a Contract presented by the Owner.

The Undersigned further agrees that security in the form of a Bid Bond, certified or cashier's check in the amount of not less than five percent (5%) of Total Lump Sum Bid Price, payable to the Owner, accompanies this Bid; that the amount is not to be construed as a penalty, but as liquidated damages which said Owner will sustain by failure of the Undersigned to execute and deliver the Contract and Bond within ten (10) days of the written notification of the Award of the Contract to him; thereupon, the security shall become the property of the Owner, but if this Bid is not accepted within ninety (90) days of the time set for the submission of Bids, or if the Undersigned delivers the executed Contract upon receipt, the Security shall be returned to the Bidder within seven (7) working days.

BID NO: 21-101

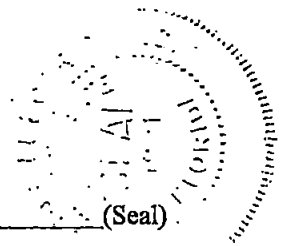

CORPORATE/COMPANY

Full Legal Company Name: Chinchor Electric, Inc.

By: [Signature] Timothy I. Chinchor, President
Signature of Authorized Representative (Name & Title typed or printed)

By: _____
Signature of Authorized Representative (Name & Title typed or printed)

Address: 1460 S Leavitt Ave, Orange City, FL 32763

Telephone No.: (386) 774 - 1020 Fax No.: (386) 774 - 7223

Email Address for Authorized Company Representative: dhasco@chinchorelectric.com

Federal I.D. Tax Number: 59-3044703 DUNS #: 783699176
(If applicable)

INDIVIDUAL

Name: [Redacted] (Name typed or printed) (Title)

Address: [Redacted]

Telephone No.: [Redacted] Fax No.: [Redacted]

Email Address: [Redacted]

Federal I.D. Tax Number: [Redacted]

- Submittal Requirements:
- Official County Unit Price Bid Form
 - Attachment "A" – St Johns County Board of County Commissioners Affidavit
 - Attachment "B" – Certificate as to Corporate Principal
 - Attachment "C" – License / Certification List
 - Attachment "D" – List of Proposed Sub-Contractors/Suppliers
 - Attachment "E" – Conflict of Interest Disclosure Form
 - Attachment "F" – Drug-Free Workplace Form
 - Attachment "G" – Proof of Insurance
 - Attachment "H" – Experience of Bidder Form
 - Attachment "I" – Claims, Liens, Litigation History
 - Attachment "J" – E-Verify Affidavit
 - Attachment "K" – Certificate of Compliance with Florid Trench Safety Act
 - Attachment "L" – Sworn Statement on Public Entity Crimes
 - Attachment "M" – Certification Regarding Debarment, Suspension, Ineligibility & Voluntary Exclusion
 - Attachment "N" – Certification for Disclosure of Lobbying Activities
 - Attachment "O" – Unit Prices for Adjustments/Schedule of Values
 - Bid Bond Form
 - Fully Acknowledged Addenda Applicable to this bid

Official County Bid Form, Attachments, and Bid Bond must be completed, along with a fully acknowledged copy of each Addendum applicable to this Bid and submitted with each copy of the Bid Proposal.

BID NO: 21-101

ATTACHMENT "A"

ST. JOHNS COUNTY, BOARD OF COUNTY COMMISSIONERS AFFIDAVIT

TO: ST. JOHNS COUNTY, BOARD OF COUNTY COMMISSIONERS,
ST. JOHNS COUNTY, ST. AUGUSTINE, FLORIDA.

At the time the proposal is submitted, the Bidder shall attach to his Bid a sworn statement.

This sworn statement shall be an affidavit in the following form, executed by an officer of the firm, association, or corporation submitting the proposal, and shall be sworn to before a person who is authorized by law to administer oaths.

STATE OF FLORIDA, COUNTY OF ST. JOHNS

Before me, the Undersigned authority, personally appeared Timothy I. Chlnchor who being duly sworn, deposes and says he is President (Title) of the firm of Chlnchor Electric, Inc. Bidder submitting the attached proposal for the services covered by the bid documents for Bid No: 21-101; Signalization Replacement at Intersection of US 1 / Lewis Point Road / St. Augustine South Drive - HMGP 4283-011-R, in St. Johns County, Florida.

The affiant further states that no more than one proposal for the above-referenced project will be submitted from the individual, his firm or corporation under the same or different name, and that such Bidder has no financial interest in the firm of another bidder for the same work. That neither he, his firm, association nor corporation has either directly or indirectly entered into any agreement, participated in any collusion, nor otherwise taken any action in restraint of free competitive bidding in connection with this firm's Bid on the above-described project. Furthermore, neither the firm nor any of its officers are ~~banned from participating~~ in public contract lettings in the State of Florida or any other state.

Chlnchor Electric, Inc.
(Bidder)

By: Timothy I. Chlnchor
President
(Title)

Sworn and subscribed to me this 21st day of JULY, 2021.

Notary Public:
[Signature]
Signature
Madison Lankford
Printed



Madison Lankford
Notary Public
State of Florida
Comm# HH072136
Expires 12/14/2024

My commission Expires: 12/14/24

BIDDER ON ALL COUNTY PROJECTS MUST EXECUTE AND ATTACH THIS AFFADAVIT TO EACH BID.

ATTACHMENT "B"

CERTIFICATES AS TO CORPORATE PRINCIPAL

I, Kathryn Quintana, certify that I am the Secretary of the Corporation named as Principal in the attached bond; that Timothy J. Chinchar who signed the said bond on behalf of the Principal, was then President of said Corporation; that I know his signature, and his signature hereto is genuine; and that said bond was duly signed, sealed, and attested for and in behalf of said Corporation by authority of its governing body.

Kathryn Quintana
Secretary Corporate Seal



(STATE OF FLORIDA
COUNTY OF ~~ST. JOHNS~~) ORANGE

Before me, a Notary Public duly commissioned, qualified and acting, personally appeared* to me well known, who being by me first duly sworn upon oath, says that he is the Attorney-In-Fact, for the** and that he has been authorized by United Fire & Casualty Company to execute the foregoing bond on behalf of the surety named therein in favor of St. Johns County, Florida.

Subscribed and sworn to me this 21st day of July, 2021, A.D.

*Teresa L. Durham

**United Fire & Casualty Company

Coralise Medal
NOTARY PUBLIC
State of Florida-at-large

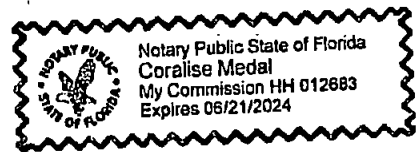

My Commission Expires: 06/21/2024

(Attach Power of Attorney to original Bid Bond and Financial Statement of Surety Company)



[Department of State](#) / [Division of Corporations](#) / [Search Records](#) / [Search by Entity Name](#) /

Detail by Entity Name

Florida Profit Corporation
CHINCHOR ELECTRIC, INC.

Filing Information

Document Number S19759
FEI/EIN Number 59-3044703
Date Filed 12/17/1990
Effective Date 01/01/1991
State FL
Status ACTIVE
Last Event AMENDMENT
Event Date Filed 04/15/2021
Event Effective Date NONE

Principal Address

1460 SOUTH LEAVITT AVENUE
ORANGE CITY, FL 32763

Changed: 01/15/2019

Mailing Address

1460 SOUTH LEAVITT AVENUE
ORANGE CITY, FL 32763

Changed: 01/15/2019

Registered Agent Name & Address

CHINCHOR, TIMOTHY Z.
119 TWISTED OAK TRAIL
DELTONA, FL 32725

Address Changed: 03/17/1992

Officer/Director Detail

Name & Address

Title VP

SOLTIS, JEFF C
1579 DEERFIELD AVE
DELTONA, FL 32725

Title P

CHINCHOR, TIMOTHY I
420 GREENRIDGE CT
DEBARY, FL 32713

Title CEO

CHINCHOR, TIMOTHY Z
119 TWISTED OAK TRAIL
DELTONA, FL 32725

Title D

HASCO, DONALD J
2374 KENNINGTON COVE
DELAND, FL 32724

Title C

CHINCHOR, TIMOTHY Z
119 TWISTED OAK TRAIL
DELTONA, FL 32725

Title D

FUDGE, BRETON R
2141 HONTOON ROAD
DELAND, FL 32720

Title D

CHINCHOR, DANIEL S.
322 W. FREESIA CT
DeLand, FL 32724

Title CFO

SURMIAK, ZACHARY D
5263 PINE LILY CIRCLE
WINTER PARK, FL 32792

Title V

ANSELMO, MARIAH
2401 LAKE STREET
DELTONA, FL 32738

Title S

QUINTANA, KATHRYN M

3529 PATRON AVE
DELTONA, FL 32738

Annual Reports

Report Year	Filed Date
2019	01/15/2019
2020	02/19/2020
2021	02/09/2021

Document Images

04/15/2021 -- Amendment	View image in PDF format
02/09/2021 -- ANNUAL REPORT	View image in PDF format
01/14/2021 -- Amendment	View image in PDF format
03/25/2020 -- Amendment	View image in PDF format
02/19/2020 -- ANNUAL REPORT	View image in PDF format
01/15/2019 -- ANNUAL REPORT	View image in PDF format
05/25/2018 -- Amendment	View image in PDF format
01/18/2018 -- ANNUAL REPORT	View image in PDF format
01/16/2017 -- ANNUAL REPORT	View image in PDF format
01/28/2016 -- ANNUAL REPORT	View image in PDF format
03/10/2015 -- Amendment	View image in PDF format
02/27/2015 -- ANNUAL REPORT	View image in PDF format
01/14/2014 -- ANNUAL REPORT	View image in PDF format
03/19/2013 -- ANNUAL REPORT	View image in PDF format
04/24/2012 -- Amendment	View image in PDF format
01/26/2012 -- ANNUAL REPORT	View image in PDF format
02/15/2011 -- ANNUAL REPORT	View image in PDF format
02/19/2010 -- ANNUAL REPORT	View image in PDF format
03/24/2009 -- ANNUAL REPORT	View image in PDF format
01/14/2008 -- ANNUAL REPORT	View image in PDF format
01/10/2007 -- ANNUAL REPORT	View image in PDF format
04/27/2006 -- ANNUAL REPORT	View image in PDF format
03/01/2005 -- ANNUAL REPORT	View image in PDF format
04/20/2004 -- ANNUAL REPORT	View image in PDF format
01/13/2003 -- ANNUAL REPORT	View image in PDF format
04/07/2002 -- ANNUAL REPORT	View image in PDF format
03/29/2001 -- ANNUAL REPORT	View image in PDF format
03/01/2000 -- ANNUAL REPORT	View image in PDF format
02/19/1999 -- ANNUAL REPORT	View image in PDF format
05/06/1998 -- ANNUAL REPORT	View image in PDF format
05/07/1997 -- ANNUAL REPORT	View image in PDF format
08/05/1996 -- ANNUAL REPORT	View image in PDF format
04/28/1995 -- ANNUAL REPORT	View image in PDF format



Contractor Pre-Qualification (CPQ)



Prequalified Contractors Listing

7/15/2021 9:18:26 AM EST

[Return to Inquiry Menu](#)

Contractor with Name CHINCHOR ELECTRIC INC.
1-1 of 1 contractors

[Printer Friendly Version](#)

VENDOR NAME	HOME OFFICE ADDRESS	BIDDING OFFICE ADDRESS
CHINCHOR ELECTRIC INC. F593044703003 EXPIRES: 3/30/2022	1460 S.LEAVITT AVE. ORANGE CITY, FL 32763 (386)774-1020	1460 S. LEAVITT AVE. ORANGE CITY, FL 32763 (386)774-1020

WORK CLASSES
COMPUTERIZED TRAFFIC CONTROL
INTELLIGENT TRANSPORTATION SYSTEMS
SIDEWALK
* Drilled Shafts.
ELECTRICAL WORK
ROADWAY SIGNING
TRAFFIC SIGNAL



FLORIDA DEPARTMENT OF TRANSPORTATION
 Report Technical Problems to the Service Desk @ 1-866-955-4357 or email: [Service Desk](#)
 Send Prequalification Questions or Comments to [Contracts Administration Office](#).
[Internet Privacy Policy, Disclaimers & Credits](#)





Florida Department of Transportation

RON DESANTIS
GOVERNOR

605 Suwannee Street
Tallahassee, FL 32399-0450

KEVIN J. THIBAUT, P.E.
SECRETARY

March 12, 2021

CHINCHOR ELECTRIC INC.
1460 S. LEAVITT AVE.
ORANGE CITY, FLORIDA 32763

REVISED

RE: CERTIFICATE OF QUALIFICATION

Dear Sir/Madam:

The Department of Transportation has qualified your company for the type of work indicated below. Unless your company is notified otherwise, this Certificate of Qualification will expire 3/30/2022. However, the new application is due 1/31/2022.

In accordance with S.337.14 (1) F.S. your next application must be filed within (4) months of the ending date of the applicant's audited annual financial statements.

If your company's maximum capacity has been revised, you can access it by logging into the Contractor Prequalification Application System via the following link:
<HTTPS://fdotwp1.dot.state.fl.us/ContractorPreQualification/>

Once logged in, select "View" for the most recently approved application, and then click the "Manage" and "Application Summary" tabs.

FDOT APPROVED WORK CLASSES:

COMPUTERIZED TRAFFIC CONTROL, ELECTRICAL WORK, INTELLIGENT TRANSPORTATION SYSTEMS, ROADWAY SIGNING, SIDEWALK, TRAFFIC SIGNAL, Drilled Shafts.

You may apply for a Revised Certificate of Qualification at any time prior to the expiration date of this certificate according to Section 14-22.0041(3), Florida Administrative Code (F.A.C.), by accessing your most recently approved application as shown above and choosing "Update" instead of "View." If certification in additional classes of work is desired, documentation is needed to show that your company has done such work with your own forces and equipment or that experience was gained with another contractor and that you have the necessary equipment for each additional class of work requested.

All prequalified contractors are required by Section 14-22.006(3), F.A.C., to certify their work underway monthly in order to adjust maximum bidding capacity to available bidding capacity. You can find the link to this report at the website shown above.

Sincerely,

Darlene Anderson, for

Alan Autry, Manager
Contracts Administration Office

AA:cg

Improve Safety, Enhance Mobility, Inspire Innovation
www.fdot.gov



**STATE OF FLORIDA
DEPARTMENT OF BUSINESS AND PROFESSIONAL REGULATION**

ELECTRICAL CONTRACTORS LICENSING BOARD
2401 BLAIR STONE ROAD
TALLAHASSEE FL 32399-0783

(850) 487-1395

Congratulations! With this license you become one of the nearly one million Floridians licensed by the Department of Business and Professional Regulation. Our professionals and businesses range from architects to yacht brokers, from boxers to barbeque restaurants, and they keep Florida's economy strong.

Every day we work to improve the way we do business in order to serve you better. For information about our services, please log onto www.myfloridalicense.com. There you can find more information about our divisions and the regulations that impact you, subscribe to department newsletters and learn more about the Department's initiatives.

Our mission at the Department is: License Efficiently. Regulate Fairly. We constantly strive to serve you better so that you can serve your customers. Thank you for doing business in Florida, and congratulations on your new license!



STATE OF FLORIDA DEPARTMENT OF BUSINESS AND PROFESSIONAL REGULATION

EC13004865: ISSUED: 07/02/2020
 CERTIFIED ELECTRICAL CONTRACTOR
 CHINCHOR, TIMOTHY IAN
 CHINCHOR ELECTRIC, INC.



Signature:
 LICENSED UNDER CHAPTER 489, FLORIDA STATUTES
 EXPIRATION DATE: AUGUST 31, 2022

Ron DeSantis, Governor Halsey Beshears, Secretary

**STATE OF FLORIDA
DEPARTMENT OF BUSINESS AND PROFESSIONAL REGULATION
ELECTRICAL CONTRACTORS LICENSING BOARD**

LICENSE NUMBER: EC13004865 **EXPIRATION DATE: AUGUST 31, 2022**

THE ELECTRICAL CONTRACTOR HEREIN IS CERTIFIED UNDER THE PROVISIONS OF CHAPTER 489, FLORIDA STATUTES

CHINCHOR, TIMOTHY IAN
 CHINCHOR ELECTRIC, INC.
 1460 S LEAVITT AVE
 ORANGE CITY, FL 32763



ISSUED: 07/02/2020

Always verify licenses online at MyFloridaLicense.com
 Do not alter this document in any form.
 This is your license. It is unlawful for anyone other than the licensee to use this document.



Ron DeSantis, Governor

Halsey Beshears, Secretary



**STATE OF FLORIDA
DEPARTMENT OF BUSINESS AND PROFESSIONAL REGULATION**

ELECTRICAL CONTRACTORS LICENSING BOARD

THE ELECTRICAL CONTRACTOR HEREIN IS CERTIFIED UNDER THE
PROVISIONS OF CHAPTER 489, FLORIDA STATUTES

CHINCHOR, TIMOTHY IAN

CHINCHOR ELECTRIC INC
1460 S LEAVITT AVE
ORANGE CITY FL 32763

LICENSE NUMBER: EC13004865

EXPIRATION DATE: AUGUST 31, 2022

Always verify licenses online at MyFloridaLicense.com



Do not alter this document in any form.

This is your license. It is unlawful for anyone other than the licensee to use this document.

ATTACHMENT "D"

LIST OF PROPOSED SUB-CONTRACTORS/SUPPLIERS

All subcontractors and major materials suppliers are subject to approval of Owner. The following are subcontractors and manufacturers of materials and/or equipment that are proposed to be utilized by the Contractor in the performance of this work.

The bidder shall attach a copy of each current license and/or FDOT pre-qualification letters for the Sub-Contractor(s) listed below to this form.

Company Name	Division/Discipline	Primary Contact Name	Contact Number and Email Address
Reliant Underground	Conduit Underground	Erica Sparks	(719)-355-0242 esparks@rellantunderground.com
Emerald Coast Striping, LLC	Pavement Markings	Eli Gerrell	(850)-545-5965 egerell@gmail.com
Advanced Cabling Solutions	ITS	Robert Loyer	(407)-339-6636 l.roman@acstraffic.net
Trafficware	Video Detection Controllers	Greg Freel	(904)-613-9331 greg.Freel@cubic.com
Rainbow Distributors	Signal Hardware/ Mastarms	Becky Osborne	becky@rainbowdistributorsusa.com 386-330-6363
Temple Inc	Signal Hardware	Keith Frasier	(800)-633-3221 Keith.Frasier@temple-inc.com

BID NO: 21-101

ATTACHMENT "E"

St. Johns County Board of County Commissioners

CONFLICT OF INTEREST DISCLOSURE FORM

Project (RFQ, RFP, BID) Number/Description: Bid No 21-101; Signalization Replacement at Intersection of US 1 / Lewis Point Road / St. Augustine South Drive - HMGP 4283-011-R

The term "conflict of interest" refers to situations in which financial or other considerations may adversely affect, or have the appearance of adversely affecting a consultant's/contractor's professional judgment in completing work for the benefit of St. Johns County ("County"). The bias such conflicts could conceivably impart may inappropriately affect the goals, processes, methods of analysis or outcomes desired by the County.

Consultants/Contractors are expected to safeguard their ability to make objective, fair, and impartial decisions when performing work for the benefit of the County. Consultants/Contractors, therefore must avoid situations in which financial or other considerations may adversely affect, or have the appearance of adversely affecting the consultant's/contractor's professional judgement when completing work for the benefit of the County.

The mere appearance of a conflict may be as serious and potentially damaging as an actual distortion of goals, processes, and methods of analysis or outcomes. Reports of conflicts based upon appearances can undermine public trust in ways that may not be adequately restored even when the mitigating facts of a situation are brought to light. Apparent conflicts, therefore, should be disclosed and evaluated with the same vigor as actual conflicts.

It is expressly understood that failure to disclose conflicts of interest as described herein may result in immediate disqualification from evaluation or immediate termination from work for the County.

Please check the appropriate statement:

I hereby attest that the undersigned Respondent has no actual or potential conflict of interest due to any other clients, contracts, or property interests for completing work on the above referenced project.

The undersigned Respondent, by attachment to this form, submits information which may be a potential conflict of interest due to other clients, contracts or property interests for completing work on the above referenced project.

Legal Name of Respondent:

Chinchor Electric, Inc.

Authorized Representative(s) :

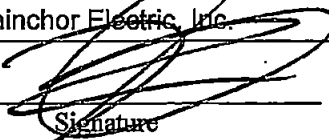
Signature

Timothy I. Chinchor, President

Print Name/Title

Signature

Print Name/Title

St. Johns County Board of County Commissioners

ATTACHMENT "F"

DRUG-FREE WORKPLACE FORM

The undersigned firm, in accordance with Florida Statute 287.087 hereby certifies that

Chinchor Electric, Inc. does:

Name of Firm

1. Publish a statement notifying employees that the unlawful manufacture, distribution, dispensing, possession or use of a controlled substance is prohibited in the workplace and specifying the actions that will be taken against employees for violations of such prohibition.
2. Inform employees about the danger of drug abuse in the workplace, the business' policy of maintaining a drug-free workplace, any available drug counseling, rehabilitation, employee assistance programs and the penalties that may be imposed upon employees for drug abuse violations.
3. Give each employee engaged in providing the contractual services that are described in St. Johns County's request for proposals a copy of the statement specified in paragraph 1.
4. In the statement specified in paragraph 1, notify the employees that, as a condition of working on the contractual services described in paragraph 3, the employee will abide by the terms of the statement and will notify the employer of any conviction of, or plea of guilty or nolo contendere to, any violation of Florida Statute 893, as amended, or of any controlled substance law of the United States or any state, for a violation occurring in the workplace no later than five (5) days after such conviction or plea.
5. Impose a sanction on, or require the satisfactory participation in a drug abuse assistance or rehabilitation program if such is available in the employee's community by, any employee who is so convicted.
6. Consistent with applicable provisions with State or Federal law, rule, or regulation, make a good faith effort to continue to maintain a drug-free workplace through implementation of paragraphs 1 through 5.

As the person authorized to sign this statement, I certify that this firm complies fully with the above requirements.



Signature

7/21/2021

Date

BID NO: 21-101

ATTACHMENT "G"

PROOF OF INSURANCE

Respondents shall provide certificates of insurance as part of their submittal package. Certificates of insurance shall meet or exceed the requirements as described under Insurance.

Failure to provide proof of current insurance coverage or ability to obtain the required coverages may result in being deemed non-responsive and removed from further consideration.

(Attach or insert copy of "Certificate of Insurance" here)



CERTIFICATE OF LIABILITY INSURANCE

DATE (MM/DD/YYYY)
09/01/2020

THIS CERTIFICATE IS ISSUED AS A MATTER OF INFORMATION ONLY AND CONFERS NO RIGHTS UPON THE CERTIFICATE HOLDER. THIS CERTIFICATE DOES NOT AFFIRMATIVELY OR NEGATIVELY AMEND, EXTEND OR ALTER THE COVERAGE AFFORDED BY THE POLICIES BELOW. THIS CERTIFICATE OF INSURANCE DOES NOT CONSTITUTE A CONTRACT BETWEEN THE ISSUING INSURER(S), AUTHORIZED REPRESENTATIVE OR PRODUCER, AND THE CERTIFICATE HOLDER.

IMPORTANT: If the certificate holder is an ADDITIONAL INSURED, the policy(ies) must have ADDITIONAL INSURED provisions or be endorsed. If SUBROGATION IS WAIVED, subject to the terms and conditions of the policy, certain policies may require an endorsement. A statement on this certificate does not confer rights to the certificate holder in lieu of such endorsement(s).

PRODUCER Brown & Brown of Florida, Inc. P.O. Box 2412 Daytona Beach FL 32115-2415	CONTACT NAME: Denise D'Abato	PHONE (A/C, No, Ext): (386) 239-7281	FAX (A/C, No): (386) 323-9121
	E-MAIL ADDRESS: ddabato@bbdaytona.com		
INSURED CHINCHOR ELECTRIC, INC. 1460 SOUTH LEAVITT AVE. ORANGE CITY FL 32763	INSURER(S) AFFORDING COVERAGE		NAIC #
	INSURER A: Amerisure Insurance Company		19488
	INSURER B: XL Specialty Insurance Company		37885
	INSURER C: The North River Insurance Company		21105
	INSURER D: L.Loyd's of London		19224
	INSURER E: Liberty Surplus Lines Ins. Corporation		10725
INSURER F:			

COVERAGES CERTIFICATE NUMBER: 20-21 REVISION NUMBER:

THIS IS TO CERTIFY THAT THE POLICIES OF INSURANCE LISTED BELOW HAVE BEEN ISSUED TO THE INSURED NAMED ABOVE FOR THE POLICY PERIOD INDICATED. NOTWITHSTANDING ANY REQUIREMENT, TERM OR CONDITION OF ANY CONTRACT OR OTHER DOCUMENT WITH RESPECT TO WHICH THIS CERTIFICATE MAY BE ISSUED OR MAY PERTAIN, THE INSURANCE AFFORDED BY THE POLICIES DESCRIBED HEREIN IS SUBJECT TO ALL THE TERMS, EXCLUSIONS AND CONDITIONS OF SUCH POLICIES. LIMITS SHOWN MAY HAVE BEEN REDUCED BY PAID CLAIMS.

INSR LTR	TYPE OF INSURANCE	ADDL SUBR INSD WVD	POLICY NUMBER	POLICY EFF (MM/DD/YYYY)	POLICY EXP (MM/DD/YYYY)	LIMITS
E	<input checked="" type="checkbox"/> COMMERCIAL GENERAL LIABILITY <input type="checkbox"/> CLAIMS-MADE <input checked="" type="checkbox"/> OCCUR GEN'L AGGREGATE LIMIT APPLIES PER: <input type="checkbox"/> POLICY <input checked="" type="checkbox"/> PRO-JECT <input type="checkbox"/> LOC OTHER:		100043251501	08/30/2020	08/30/2021	EACH OCCURRENCE \$ 1,000,000 DAMAGE TO RENTED PREMISES (Ea occurrence) \$ 50,000 MED EXP (Any one person) \$ 5,000 PERSONAL & ADV INJURY \$ 1,000,000 GENERAL AGGREGATE \$ 2,000,000 PRODUCTS - COMP/OP AGG \$ 2,000,000
A	AUTOMOBILE LIABILITY <input checked="" type="checkbox"/> ANY AUTO <input type="checkbox"/> OWNED AUTOS ONLY <input type="checkbox"/> SCHEDULED AUTOS <input type="checkbox"/> HIRED AUTOS ONLY <input type="checkbox"/> NON-OWNED AUTOS ONLY		CA21060480301	08/30/2020	08/30/2021	COMBINED SINGLE LIMIT (Ea accident) \$ 1,000,000 BODILY INJURY (Per person) \$ BODILY INJURY (Per accident) \$ PROPERTY DAMAGE (Per accident) \$ PIP-Basic \$ 10,000
C	UMBRELLA LIAB <input checked="" type="checkbox"/> OCCUR EXCESS LIAB <input type="checkbox"/> CLAIMS-MADE DED <input checked="" type="checkbox"/> RETENTION \$ 0		5821147125	08/30/2020	08/30/2021	EACH OCCURRENCE \$ 5,000,000 AGGREGATE \$ 5,000,000 PROD/C-OP \$ 5,000,000
A	WORKERS COMPENSATION AND EMPLOYERS' LIABILITY ANY PROPRIETOR/PARTNER/EXECUTIVE OFFICER/MEMBER EXCLUDED? (Mandatory In NH) If yes, describe under DESCRIPTION OF OPERATIONS below	Y/N N	WC21060470301	08/30/2020	08/30/2021	<input checked="" type="checkbox"/> PER STATUTE <input type="checkbox"/> OTH-ER E.L. EACH ACCIDENT \$ 1,000,000 E.L. DISEASE - EA EMPLOYEE \$ 1,000,000 E.L. DISEASE - POLICY LIMIT \$ 1,000,000
B	INLAND MARINE		UM00058950MA20A	08/30/2020	08/30/2021	RENTED EQUIPMENT \$100,000 INSTALLATION \$250,000

DESCRIPTION OF OPERATIONS / LOCATIONS / VEHICLES (ACORD 101, Additional Remarks Schedule, may be attached if more space is required)

SEE NOTES FOR POLICY COVERAGE FORMS FOR INFORMATION ONLY

CERTIFICATE HOLDER

CANCELLATION

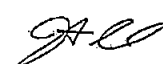
CHINCHOR ELECTRIC INC 1460 SOUTH LEAVITT AVE ORANGE CITY FL 32763	SHOULD ANY OF THE ABOVE DESCRIBED POLICIES BE CANCELLED BEFORE THE EXPIRATION DATE THEREOF, NOTICE WILL BE DELIVERED IN ACCORDANCE WITH THE POLICY PROVISIONS. AUTHORIZED REPRESENTATIVE 
---	--

© 1988-2015 ACORD CORPORATION. All rights reserved.

AGENCY CUSTOMER ID: _____

LOC #: _____



ADDITIONAL REMARKS SCHEDULE

Page _____ of _____

AGENCY Brown & Brown of Florida, Inc.	NAMED INSURED CHINCHOR ELECTRIC, INC.
POLICY NUMBER	EFFECTIVE DATE:
CARRIER	NAIC CODE

ADDITIONAL REMARKS

THIS ADDITIONAL REMARKS FORM IS A SCHEDULE TO ACORD FORM,

FORM NUMBER: 25 **FORM TITLE:** Certificate of Liability Insurance: Notes

INSURER D - PROFESSIONAL/POLLUTION LIABILITY

POLICY NUMBER: B0621PCHIN000220

08/30/2020 TO 08/30/2021

PER OCCURENCE: \$1,000,000

AGGREGATE: \$2,000,000

CURRENT BLANKET POLICY FORMS

GENERAL LIABILITY:

- 1.) CGL1011 0103 - DESIGNATED CONSTRUCTION PROJECT(S) GENERAL AGGREGATE LIMIT SUBJECT TO A POLICY AGGREGATE LIMIT
- 2.) CG2010 0704 - ADDITIONAL INSURED - OWNERS, LESSEES OR CONTRACTORS- SCHEDULED PERSON OR ORGANIZATION
- 3.) CG2037 0704 - ADDITIONAL INSURED - OWNERS, LESSEES OR CONTRACTORS- COMPLETED OPERATIONS
- 4.) CG2034 0413 - ADDITIONAL INSURED - LESSOR OF LEASED EQUIPMENT -AUTOMATIC STATUS WHEN REQUIRED IN LEASE AGREEMENT WITH YOU
- 5.) CG20320704 - ADDITIONAL INSURED-ENGINEERS, ARCHITECTS OR SURVEYORS NOT ENGAGED BY THE NAMED INSURED
- 6.) CG20110196 - ADDITIONAL INSURED-MANAGERS OR LESSORS OF PREMISES
- 7.) CG2012 0509 - ADDITIONAL INSURED - STATE OR GOVERNMENTAL AGENCY OR SUBDIVISION OR POLITICAL SUBDIVISION - PERMITS
- 8.) CG2404 0509 - WAIVER OF TRANSFER OF RIGHTS OF RECOVERY AGAINST OTHERS TO US
- 9.) CGL1031 0413 - PRIMARY INSURANCE CLAUSE ENDORSEMENT (PRIMARY AND NON-CONTRIBUTORY)
- 10.) LSI CN001 FL 1014 - CANCELLATION NON-RENEWAL ENDORSEMENT- FL

AUTO LIABILITY:

- 1.) CA7171 0508-FLORIDA ADVANTAGE COMMERCIAL AUTOMOBILE BROAD FORM ENDORSEMENT (ADDITIONAL INSURED, WAIVER OF SUBROGATION)
- 2.) CA2001 1013-LESSOR -ADDITIONAL INSURED AND LOSS PAYEE
- 3.) CA7165 0911-DESIGNATED INSURED-PRIMARY NON-CONTRIBUTORY COVERAGE WHEN REQUIRED BY INSURED CONTRACT OR CERTIFICATE
- 4.) IL7074 0116-NOTICE OF CANCELLATION, NONRENEWAL OR MATERIAL CHANGE -- THIRD PARTY

WORKERS COMPENSATION:

- 1.) WC000313 0484-WAIVER OF OUR RIGHT TO RECOVER FROM THE OTHERS ENDORSEMENT
- 2.) WC990902 0607-NOTICE OF CANCELLATION AND NON-RENEWAL TO THIRD PARTIES

UMBRELLA LIABILITY:

- 1.) FM101.0.302 0818 - EXCESS LIABILITY INSURANCE POLICY DECLARATIONS (ADDITIONAL INSURED, PRIMARY & NONCONTRIBUTORY, WAIVER OF SUBROGATION)
 - 2.) FM2.0.1036 0612 - FLORIDA POLICYHOLDER NOTICE OF CANCELLATION FOR CERTIFICATE HOLDERS W/O SCHEDULE
- THE EXCESS POLICY APPLIES IN EXCESS OF THE GENERAL LIABILITY, AUTO LIABILITY AND EMPLOYERS LIABILITY. THE INSURANCE UNDER THIS POLICY WILL FOLLOW THE SAME PROVISIONS, EXCLUSIONS, CONDITIONS AND LIMITATIONS THAT ARE CONTAINED IN THE APPLICABLE CONTROLLING UNDERLYING INSURANCE, UNLESS OTHERWISE DIRECTED BY THIS POLICY.

EQUIPMENT:

HCM050 0112-BLANKET LOSS PAYEE

BID-NO: 21-101

ATTACHMENT "H"

EXPERIENCE OF BIDDER

Bidder acknowledges that he is fully licensed to perform work in the STATE OF FLORIDA.

The Bidder shall provide the following information regarding experience within the past ten (10) years of this solicitation. Bidder must demonstrate the successful completion of three (3) projects equal to or greater than the scope and dollar value of that being proposed.

Any material misrepresentation, as determined by the County, shall result in disqualification.

By: Chinchor Electric, Inc.

Bidder

Authorized Signature

7/21/2021

Date

DATE OF CONTRACT	CLIENT'S NAME, ADDRESS, PHONE AND EMAIL	CONTRACT AMOUNT	PROJECT AND LOCATION
September 2019	Florida Department of Transportation District 5 719 S. Woodland Blvd. Deland, FL 32720 386-740-3490 Frederick.Coe@dot.state.fl.us	\$1,224,239.46	T5663 SR A1A (Atlantic Drive) at Cardinal Drive and Harvard Drive Volusia County
October 2016	City of Altamonte Springs 225 Newburyport Ave. Altamonte Springs, FL 32701 407-571-8078	\$674,361.33	SR 436 Traffic Signal Installation Seminole County
September 2018	Osceola County 1 Courthouse Square, Suite 3100 Kissimmee, FL 34741 407-742-0900	\$662,185.64	Narcoossee Rd G1489 Poinciana Blvd & Siesta Lago Dr. Osceola County

ATTACHMENT "I"

CLAIMS, LIENS, LITIGATION HISTORY
(Complete and Submit)

- 1. Within the past 7 years, has your organization filed suit or a formal claim against a project owner (as a prime or subcontractor) or been sued by or had a formal claim filed by an owner, subcontractor or supplier resulting from a construction dispute? Yes _____ No X If yes, please attach additional sheet(s) to include:

Description of every action Captions of the Litigation or Arbitration

Amount at issue: _____ Name (s) of the attorneys representing all parties:

Amount actually recovered, if any: _____

Name(s) of the project owner(s)/manager(s) to include address and phone number:

- 2. List all pending litigation and or arbitration.

See attached

- 3. List and explain all litigation and arbitration within the past seven (7) years - pending, resolved, dismissed, etc.

See attached

- 4. Within the past 7 years, please list all Liens, including Federal, State and Local, which have been filed against your Company. List in detail the type of Lien, date, amount and current status of each Lien.

None

- 5. Have you ever abandoned a job, been terminated or had a performance/surety bond called to complete a job?

Yes _____ No X If yes, please explain in detail:

- 6. For all claims filed against your company within the past five-(5) years, have all been resolved satisfactorily with final judgment in favor of your company within 90 days of the date the judgment became final? Yes X No _____

If no, please explain why? _____

- 7. List the status of all pending claims currently filed against your company:

See attached

Liquidated Damages

- 1. Has a project owner ever withheld retainage, issued liquidated damages or made a claim against any Performance and Payment Bonds? Yes _____ No X If yes, please explain in detail:

(Use additional or supplemental pages as needed)

CHINCHOR ELECTRIC INC.

INDUSTRIAL

COMMERCIAL

SIGNALIZATION

CEI Claims and Litigation History

Auto Liability

Claim Number: 2145403

Claimant: Andre Small / Alili Contreras

Date of Loss: 05/17/2018

Loss Description: IV rear-ended OV1 which caused them to get pushed into OV2

Claim Status: Settlement reached in the amount of \$6,000 for Alili Contreras. No demand received for Andre Small. current reserves set at \$15,000

General Liability

Claim Number: 2185051

Claimant: Sebastian Duque

Date of Loss: 12/26/17

Loss Description: Estate of Sebastian Duque alleges Chinchor failed to operate crosswalk machine leading to a malfunctioning cross walk light which resulted in Sebastian Duque being struck by a car and sustaining fatal injuries.

Claim Status: Initial indemnity reserves set at \$50,000 and \$25,000 in expense. Carrier has assigned council in anticipation of litigation. Currently working to obtain logs and homicide report to determine liability.

STATE LICENSE EC 0002457 EC 13004865

1460 SOUTH LEAVITT AVE • ORANGE CITY, FL 32763 • 386-774-1020 • FAX 386-774-7223

BID NO: 21-101

ATTACHMENT "J"
E-VERIFY AFFIDAVIT

STATE OF Florida
COUNTY OF Volusia

I, Timothy I. Chinchor, President (hereinafter "Affiant"), being duly authorized by and on behalf of Chinchor Electric, Inc. (hereinafter "Consultant/Contractor") hereby swears or affirms as follows:

1. Consultant/Contractor understands that E-Verify, authorized by Illegal Immigration Reform and Immigrant Responsibility Act of 1996 (IIRIRA), is a web-based system provided by the United States Department of Homeland Security, through which employers electronically confirm the employment eligibility of their employees.
2. For the duration of Contract No. 21-101; HMGP 4283-011-R (hereinafter "Agreement"), in accordance with section 448.095, F.S., Consultant/Contractor shall utilize the U.S. Department of Homeland Security's E-Verify system to verify the employment eligibility of all new employees hired by the Consultant/Contractor and shall expressly require any subcontractors performing work or providing services pursuant to the Agreement to likewise utilize the U.S. Department of Homeland Security's E-Verify system to verify the employment eligibility of all new employees hired by the subcontractor.
3. Consultant/Contractor shall comply with all applicable provisions of section 448.095, F.S., and will incorporate in all subcontracts the obligation to comply with section 448.095, F.S.
4. Consultant/Contractor understands and agrees that its failure to comply with all applicable provisions of section 448.095, F.S. or its failure to ensure that all employees and subcontractors performing work under the Agreement are legally authorized to work in the United States and the State of Florida constitute a breach of the Agreement for which St. Johns County may immediately terminate the Agreement without notice and without penalty. The Consultant/Contractor further understands and agrees that in the event of such termination, Consultant/Contractor shall be liable to the St. Johns County for any costs incurred by the St. Johns County resulting from Consultant/Contractor's breach.

DATED this 21st day of July, 2021.

[Signature]
Signature of Affiant

Timothy I. Chinchor
Printed Name of Affiant

President
Printed Title of Affiant

Chinchor Electric, Inc.
Full Legal Name of Consultant/Contractor

Sworn to (or affirmed) and subscribed before me by means of physical presence or online notarization, this 21st day of July, 2021, by Timothy Chinchor, who is personally known to me or has produced _____ as identification.

[Signature]
Notary Public
My Commission Expires: 12/14/24

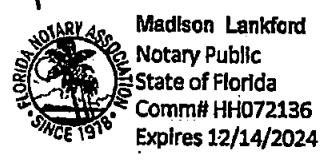

BID NO: 21-101

ATTACHMENT "K"

CERTIFICATE OF COMPLIANCE WITH FLORIDA TRENCH SAFETY ACT

Bidder acknowledges that he is solely responsible for complying with the Florida Trench Safety Act (ACT) and Occupational Safety and Health Administrations excavation safety standard 29 CFR 1926.650 (Subpart P as amended) and the St. Johns County Trenching and Excavation Safety Program. If there is a conflict between the ACT and the St. Johns County Trenching and Excavation Safety Program, the more stringent requirement would apply. Bidder further acknowledges that included in the various items of the proposal and in the Total Bid Price are costs for complying with the Florida Trench Safety Act (90-96, Laws of Florida) effective October 1, 1990 and the Occupational Safety and Health Administrations excavation safety standard.

By: Timothy I. Chinchor

Chinchor Electric, Inc.

Bidder

Authorized Signature

7/21/2021
Date

ATTACHMENT "L"

SWORN STATEMENT UNDER SECTION 287.133(3)(A), FLORIDA STATUTES, ON PUBLIC ENTITY CRIMES

(To be signed in the presence of notary public or other officer authorized to administer oaths.)

Before me, the undersigned Authority, personally appeared affiant Timothy I. Chinchor, who, being by me first duly sworn, made the following statement:

1. The business address of Chinchor Electric, Inc. (name of Offeror or business) is 1460 S Leavitt Ave, Orange City, FL 32763.
2. My relationship to Chinchor Electric, Inc. (name of Offeror or business) is President (relationship such as sole proprietor, partner, president, vice president).
3. I understand that a public entity crime as defined in Section 287.133 of the Florida Statutes includes a violation of any state or federal law by a person with respect to and directly related to the transaction of business with any public entity in Florida or with an agency or political subdivision of any other state or with the United States, including, but not limited to, any proposal or contract for goods or services to be provided to any public entity or such an agency or political subdivision and involving antitrust, fraud, theft, bribery, collusion, racketeering, conspiracy or material misrepresentation.
4. I understand that "convicted" or "conviction" is defined by the Florida Statutes to mean a finding of guilt or a conviction of a public entity crime, with or without an adjudication of guilt, in any federal or state trial court of record relating to charges brought by indictment or information after July 1, 1989, as a result of a jury verdict, non-jury trial, or entry of a plea of guilt or nolo contendere.
5. I understand that "affiliate" is defined by the Florida Statutes to mean (1) a predecessor or successor of a person or a corporation convicted of a public entity crime, or (2) an entity under the control of any natural person who is active in the management of the entity and who has been convicted of a public entity crime, or (3) those officers, directors, executives, partners, shareholders, employees, members, and agents who are active in the management of an affiliate, or (4) a person or corporation who knowingly entered into a joint venture with a person who has been convicted of a public entity crime in Florida during the preceding 36 months.
6. Neither the Offeror or contractor, nor any officer, director, executive, partner, shareholder, employee, member or agent who is active in the management of the Offeror or contractor, nor any affiliate of the Offeror or contractor has been convicted of a public entity crime subsequent to July 1, 1989. (Draw a line through paragraph 6 if paragraph 7 below applies.)
7. ~~There has been a conviction of a public entity crime by the Offeror or contractor, or an officer, director, executive, partner, shareholder, employee, member or agent of the Offeror or contractor who is active in the management of the Offeror or contractor or an affiliate of the Offeror or contractor. A determination has been made pursuant to Section 287.133(3) by order of the Division of Administrative Hearings that it is not in the public interest for the name of the convicted person or affiliate to appear on the convicted vendor list. The name of the convicted person or affiliate is NA. A copy of the order of the Division of Administrative Hearings is attached to this statement. (Draw a line through paragraph 7 if paragraph 6 above applies.)~~

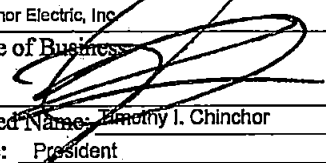
Chinchor Electric, Inc.
 Name of Business
 By: 
 Printed Name: Timothy I. Chinchor
 Title: President

STATE OF Florida
 COUNTY OF Volusia

Sworn to (or affirmed) and subscribed before me this 21st day of JULY, 2021, by Timothy Chinchor, as PRESIDENT of Chinchor Electric, Inc. and who:

[Notary: Please select one]
 is personally known to me; or
 has produced _____ as identification.

 Notary Public, State of Florida
 Printed, typed or stamped name, commission and expiration:

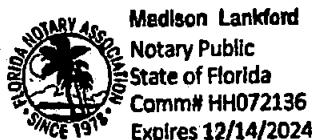

ATTACHMENT "M"

(Complete and Submit Attachment "M" for Prime Bidder and each proposed Sub-Contractor)

**Certification Regarding
Debarment, Suspension,
Ineligibility and Voluntary Exclusion**

Subcontractor Covered Transactions

- (1) The prospective subcontractor, Chinchor Electric, Inc. of the Sub-Recipient certifies, by submission of this document, that neither it nor its principals is presently debarred, suspended, proposed for debarment, declared ineligible or voluntarily excluded from participation in this transaction by any Federal department or agency.
- (2) Where the Sub-Recipient's subcontractor is unable to certify to the above statement, the prospective contractor shall attach an explanation to this form.

SUBCONTRACTOR:

Chinchor Electric, Inc.

By 
Signature

Timothy I. Chinchor, President
Name and Title

1460 S Leavitt Ave
Street Address

Orange City, FL 32763
City, State, Zip

7/21/2021
Date

St. Johns County BOCC
Sub-Recipient's Name

H0013
Division Contract Number

#4283-011-R
HMGP Project Number

BID NO: 21-101

ATTACHMENT "M"

(Complete and Submit Attachment "M" for Prime Bidder and each proposed Sub-Contractor)

**Certification Regarding
Debarment, Suspension,
Ineligibility and Voluntary Exclusion**

Subcontractor Covered Transactions

- (1) The prospective subcontractor, Advanced Cabling Solutions of the Sub-Recipient certifies, by submission of this document, that neither it nor its principals is presently debarred, suspended, proposed for debarment, declared ineligible or voluntarily excluded from participation in this transaction by any Federal department or agency.
- (2) Where the Sub-Recipient's subcontractor is unable to certify to the above statement, the prospective contractor shall attach an explanation to this form.

SUBCONTRACTOR:

Advanced Cabling Solutions

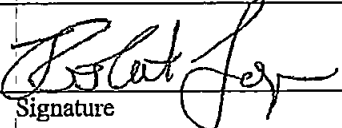
By 
Signature

St. Johns County BOCC
Sub-Recipient's Name

ROBERT LOYER VICE PRESIDENT
Name and Title

H0013
Division Contract Number

201 REECE WAY SUITE 1431
Street Address

#4283-011-R
HMGP Project Number

CASSELBERRY FL. 32107
City, State, Zip

7/20/2021
Date

BID NO: 21-101

ATTACHMENT "M"

(Complete and Submit Attachment "M" for Prime Bidder and each proposed Sub-Contractor)

**Certification Regarding
Debarment, Suspension,
Ineligibility and Voluntary Exclusion**

Subcontractor Covered Transactions

- (1) The prospective subcontractor, Emerald Coast Striping, LLC of the Sub-Recipient certifies, by submission of this document, that neither it nor its principals is presently debarred, suspended, proposed for debarment, declared ineligible or voluntarily excluded from participation in this transaction by any Federal department or agency.
- (2) Where the Sub-Recipient's subcontractor is unable to certify to the above statement, the prospective contractor shall attach an explanation to this form.

SUBCONTRACTOR:

Emerald Coast Striping, LLC

By Eli C. Gessell
Signature

St. Johns County BOCC
Sub-Recipient's Name

Eli Gessell Managing Partner
Name and Title

H0013
Division Contract Number

4454 Entrepot Blvd.
Street Address

#4283-011-R
HMGP Project Number

Tallahassee, FL 32310
City, State, Zip

7-20-21
Date

BID NO: 21-101

ATTACHMENT "M"

(Complete and Submit Attachment "M" for Prime Bidder and each proposed Sub-Contractor)

**Certification Regarding
Debarment, Suspension,
Ineligibility and Voluntary Exclusion**

Subcontractor Covered Transactions

- (1) The prospective subcontractor, Reliant Underground of the Sub-Recipient certifies, by submission of this document, that neither it nor its principals is presently debarred, suspended, proposed for debarment, declared ineligible or voluntarily excluded from participation in this transaction by any Federal department or agency.
- (2) Where the Sub-Recipient's subcontractor is unable to certify to the above statement, the prospective contractor shall attach an explanation to this form.

SUBCONTRACTOR:

Reliant Underground

By David Sparks
Signature

David Sparks VP
Name and Title

14400 Beverly Dr
Street Address

Astatula, FL 34705
City, State, Zip

7/20/2021
Date

St. Johns County BOCC
Sub-Recipient's Name

H0013
Division Contract Number

#4283-011-R
HMGP Project Number

ATTACHMENT "N"

CERTIFICATION FOR DISCLOSURE OF LOBBYING ACTIVITIES

The prospective participant certifies, by signing this certification, that to the best of his or her knowledge and belief:

- (1) No federal appropriated funds have been paid or will be paid, by or on behalf of the undersigned, to any person for influencing or attempting to influence an officer or employee of any federal agency, a Member of Congress, an officer or employee of Congress, or an employee of a Member of Congress in connection with the awarding of any federal contract, the making of any federal grant, the making of any federal loan, the entering into of any cooperative agreement, and the extension, continuation, renewal, amendment, or modification of any federal contract, grant, loan, or cooperative agreement.
- (2) If any funds other than federal appropriated funds have been paid or will be paid to any person for influencing or attempting to influence an officer or employee of any federal agency, a Member of Congress, an officer or employee of Congress, or an employee of a Member of Congress in connection with this federal contract, grant, loan, or cooperative agreement, the undersigned shall complete and submit Standard Form-LLL, "Disclosure of Lobbying Activities", in accordance with its instructions. (Standard Form-LLL can be obtained from the Florida Department of Transportation's Professional Services Administrator or Procurement Office.)

This certification is a material representation of fact upon which reliance was placed when this transaction was made or entered into. Submission of this certification is a prerequisite for making or entering into this transaction imposed by Section 1352, Title 31, U.S. Code. Any person who fails to file the required certification shall be subject to a civil penalty of not less than \$10,000 and not more than \$100,000 for each such failure.

The prospective participant also agrees by submitting his or her proposal that he or she shall require that the language of this certification be included in all lower tier subcontracts, which exceed \$100,000 and that all such sub recipients shall certify and disclose accordingly.

Legal Name of Contractor: Chinchor Electric, Inc.

By: Timothy I. Chinchor Date: 7/21/2021

Authorized Signature: 

Title: President

ATTACHMENT "O"

UNIT PRICES FOR ADJUSTMENT/SCHEDULE OF VALUES

The following unit prices, if approved by the Owner, will be used for adjusting the Contract Price for changes in the work (additions or deletions) in accordance with the provisions of an approved change order and any other modifications of the Contract. Unit prices shall include all labor, materials, equipment, transportation, supervision, insurance cost, bond cost, overhead and profit representing an in-place price for each item. Scope or size of each item not otherwise indicated is as described in the construction specifications and drawings.

BIDDERS MUST FILL OUT THE TABLES BELOW COMPLETELY. Failure to complete and submit Attachment "N" – Schedule of Values may result in the bid proposal being deemed non-responsive and removed from consideration for award of a contract.

Signalization Component

Pay Item	Description	Total Quantity	Unit	Unit Price	Total Amount
630 - 2- 11	CONDUIT (F&I) (OPEN TRENCH)	195	LF	\$ 13.92	\$ 2,714.40
630 - 2- 12	CONDUIT (F&I) (DIRECTIONAL BORE)	430	LF	\$ 22.04	\$ 9,477.20
632 - 7- 1	SIGNAL CABLE (F&I) (NEW OR RECONSTRUCTED INTERSECTION)	1	PI	\$ 7,482.00	\$ 7,482.00
632 - 7- 6	SIGNAL CABLE (REMOVE-INTERSECTION)	1	PI	\$ 480.24	\$ 480.24
633 - 2- 32	FIBER OPTIC CONNECTION (INSTALL) (TERMINATION)	12	EA	\$ 49.88	\$ 598.56
633 - 3- 14	FIBER OPTIC CONNECTION HARDWARE (F&I) (BUFFER TUBE FAN OUT KIT)	1	EA	\$ 87.00	\$ 87.00
633 - 3- 16	FIBER OPTIC CONNECTION HARDWARE (F&I) (PATCH PANEL- FIELD TERMINATED)	1	EA	\$ 2,030.00	\$ 2,030.00
635 - 2- 11	PULL & SPLICE BOX (F&I) (13 "x 24 " COVER SIZE)	13	EA	\$ 828.24	\$ 10,767.12
635 - 2- 12	PULL & SPLICE BOX (F&I) (24 "x 36 " COVER SIZE)	1	EA	\$ 1,452.32	\$ 1,452.32
639 - 1- 122	ELECTRICAL POWER SERVICE (F&I) (UNDERGROUND) (PURCHASED)	1	AS	\$ 3,288.60	\$ 3,288.60
639 - 2- 1	ELECTRICAL SERVICE WIRE (F&I)	130	LF	\$ 4.20	\$ 546.00
641 - 2- 12	PRESTRESSED CONCRETE POLE (F&I) (TYPE P- II SERVICE POLE)	1	EA	\$ 624.08	\$ 624.08
641 - 2- 60	PRESTRESSED CONCRETE POLE (COMPLETE POLE REMOVAL- PEDESTAL/ SERVICE POLE)	1	EA	\$ 80.04	\$ 80.04
641 - 2- 70	PRESTRESSED CONCRETE POLE (SHALLOW POLE REMOVAL- POLE 30 ' AND GREATER)	4	EA	\$ 5,521.60	\$ 22,086.40
646 - 1- 11	ALUMINUM SIGNALS POLE (F&I) (PEDESTAL)	7	EA	\$ 1,838.60	\$ 12,870.20
649 - 21 - 10	STEEL MAST ARM ASSEMBLY (F&I) (SINGLE ARM 60 ')	1	EA	\$ 37,560.80	\$ 37,560.80
649 - 21 - 15	STEEL MAST ARM ASSEMBLY (F&I) (SINGLE ARM 70 ')	2	EA	\$ 43,360.80	\$ 86,721.60
649 - 21 - 21	STEEL MAST ARM ASSEMBLY (F&I) (SINGLE ARM 78 ')	1	EA	\$ 54,148.80	\$ 54,148.80

Pay Item	Description	Total Quantity	Unit	Unit Price	Total Amount
650 - 1- 14	VEHICULAR TRAFFIC SIGNAL (F&I - ALUMINUM) (3 SECTION) (1 WAY)	9	AS	\$ 936.12	\$ 8,425.08
650 - 1- 16	VEHICULAR TRAFFIC SIGNAL (F&I - ALUMINUM) (4 SECTION) (1 WAY)	4	AS	\$ 1,224.96	\$ 4,899.84
653 - 1- 11	PEDESTRIAN SIGNAL (F&I LED COUNTDOWN) (1 WAY)	6	AS	\$ 624.08	\$ 3,744.48
653 - 1- 12	PEDESTRIAN SIGNAL (F&I LED COUNTDOWN) (2 WAYS)	1	AS	\$ 1,226.12	\$ 1,226.12
660-4-11	VEHICLE DETECTION SYSTEM-VIDEO (F&I) (CABINET EQUIPMENT)	1	EA	\$ 31,960.32	\$ 31,960.32
660-4-12	VEHICLE DETECTION SYSTEM-VIDEO (F&I) (ABOVE GROUND EQUIPMENT)	4	EA	\$ 4,120.32	\$ 16,481.28
665 - 1- 11	PEDESTRIAN DETECTOR (F&I) (STANDARD)	8	EA	\$ 236.64	\$ 1,893.12
670 - 5- 111	TRAFFIC CONTROLLER ASSEMBLY (F&I) (NEMA) (1 PRE-EMPTION PLAN)	1	AS	\$ 23,669.80	\$ 23,669.80
670 - 5- 600	TRAFFIC CONTROLLER ASSEMBLY (REMOVE CONTROLLER AND CABINET)	1	AS	\$ 640.32	\$ 640.32
682 - 1- 133	ITS CCTV CAMERA (F&I) (DOME PTZ ENCLOSURE, NON- PRESSURIZED) (IP, HIGH DEFINITION)	1	EA	\$ 7,308.00	\$ 7,308.00
684 - 1- 1	MANAGED FIELD ETHERNET SWITCH (F&I)	1	EA	\$ 1,566.00	\$ 1,566.00
684 - 6- 11	WIRELESS COMMUNICATION DEVICE (F&I) (ETHERNET ACCESS POINT)	2	EA	\$ 1,096.20	\$ 2,192.40
685 - 1- 11	UNINTERRUPTIBLE POWER SUPPLY (F&I) (LINE INTERACTIVE)	1	EA	\$ 5,584.24	\$ 5,584.24
700 - 3- 201	SIGN PANEL (F&I OVERHEAD MOUNT) (UP TO 12 SF)	7	EA	\$ 704.12	\$ 4,928.84
700 - 5- 21	INTERNALLY ILLUMINATED SIGN (F&I OVERHEAD MOUNT) (UP TO 12 SF)	2	EA	\$ 2,800.24	\$ 5,600.48
700 - 5- 22	INTERNALLY ILLUMINATED SIGN (F&I OVERHEAD MOUNT) (12 TO 18 SF)	2	EA	\$ 3,380.24	\$ 6,760.48
Signalization Component Total:					\$ 379,896.16

Roadway Component

Pay Item	Description	Total Quantity	Unit	Unit Price	Total Amount
700 - 1- 11	SINGLE POST SIGN (F&I GROUND MOUNT) (UP TO 12 SF)	1	AS	\$ 755.16	\$ 755.16
711 - 11 - 160	THERMOPLASTIC PAVEMENT MARKINGS (STANDARD) (WHITE) (MESSAGE OR SYMBOL)	2	EA	\$ 174.00	\$ 348.00
711 - 11 - 170	THERMOPLASTIC PAVEMENT MARKINGS (STANDARD) (WHITE) (ARROW)	1	EA	\$ 116.00	\$ 116.00
711 - 14 - 123	THERMOPLASTIC PAVEMENT MARKINGS (PREFORMED) (WHITE) (SOLID) (12 " FOR CROSSWALK)	799	LF	\$ 8.12	\$ 6,487.88
711 - 14 - 125	THERMOPLASTIC PAVEMENT MARKINGS (PREFORMED) (WHITE) (SOLID) (24 " FOR CROSSWALK)	684	LF	\$ 15.66	\$ 10,711.44
711 - 17	THERMOPLASTIC (REMOVE EXISTING THERMOPLASTIC PAVEMENT MARKINGS)	800	SF	\$ 4.64	\$ 3,712.00
Roadway Component Total:					\$ 22,130.48

Pay Item	Description	Total Quantity	Unit	Unit Price	Total Amount
----------	-------------	----------------	------	------------	--------------

Lighting Component

Pay Item	Description	Total Quantity	Unit	Unit Price	Total Amount
630 - 2- 11	CONDUIT (F&I) (OPEN TRENCH)	50.00	LF	\$ 13.92	\$ 696.00
630 - 2- 12	CONDUIT (F&I) (DIRECTIONAL BORE)	280.00	LF	\$ 22.04	\$ 6,171.20
635 - 2- 11	PULL & SPLICE BOX (F&I) (13 "x 24 " COVER SIZE)	6	EA	\$ 828.24	\$ 4,969.44
715 - 1- 12	LIGHTING CONDUCTORS (F&I) (ISULATED) (NO. 8 - 6)	2,982.00	LF	\$ 1.40	\$ 4,174.80
715 - 4- 13	LIGHT POLE COMPLETE (F&I STANDARD POLE STANDARD FOUNDATION) (40 ' MOUNTING HEIGHT)	3	EA	\$ 5,748.96	\$ 17,246.88
715 - 4- 31	LIGHT POLE COMPLETE (F&I UTI LI TY CONFLICT POLE) (INDEX 175 15 / 715 - 002 FOUNDATION) (30 ' MOUNTING HEIGHT)	1	EA	\$ 6,212.96	\$ 6,212.96
715 - 4- 70	LIGHT POLE COMPLETE (REMOVE POLE AND FOUNDATION)	2	EA	\$ 1,440.72	\$ 2,881.44
715 - 5- 32	LUMINAIRE & BRACKET ARM (F&I NEW LUMINAIRE AND ARM ON NEW/ EXISTING POLE) (GALVANIZED STEEL)	4	EA	\$ 1,292.24	\$ 5,168.96
715 - 500 - 1	POLE CABLE DISTRIBUTION SYSTEM (F&I) (CONVENTIONAL)	4	EA	\$ 519.68	\$ 2,078.72
Lighting Component Total:					\$ 49,600.40

Project Components Subtotal:					\$ 451,627.04
-------------------------------------	--	--	--	--	----------------------

Non-Bid Component

Pay Item	Description	Total Quantity	Unit	Unit Price	Total Amount
101 - 1	MOBI LIZ ATI ON	10.00	%		\$ 45,162.70
102 - 1	MAI NTENANCE OF TRAFFI C	15.00	%		\$ 67,744.06
	CONTI NGENCY	10.00	%		\$ 45,162.70
Non-Bid Component Total:					158,069.46

BID NO: 21-101

BID BOND

STATE OF FLORIDA
COUNTY OF ST. JOHNS

KNOW ALL MEN BY THESE PRESENTS, that Chinchor Electric, Inc. as Principal, and United Fire & Casualty Company as Surety, are held and firmly bound unto St. Johns County, Florida, in the penal sum of Five Percent of Amount Bid Dollars (\$ ---5%---) lawful money of the United States, we bind ourselves, our heirs, executors, administrators, and successors, jointly and severally, firmly by these presents.

THE CONDITION OF THIS OBLIGATIONS IS SUCH that whereas the Principal has submitted the accompanying Bid, dated July 21, 20 21.

For
**SIGNALIZATION REPLACEMENT AT INTERSECTION OF US 1 / LEWIS POINT ROAD /
ST. AUGUSTINE SOUTH DRIVE - HMGP 4283-011-R**

St. Johns County, Florida

NOW THEREFORE,

- (a) If the Principal shall not withdraw said Bid within ninety (90) days after Bid Award date, and shall within ten (10) days after prescribed forms are presented to him for signature, enter into a written Contract with the County in accordance with the Bid as accepted, and give Bond with good and sufficient Surety or Sureties, as may be required, for the faithful performance and proper fulfillment of such Contract, then the above obligations shall be void and of no effect, otherwise to remain in full force and virtue.
- (b) In the event of the withdrawal of said Bid within the period specified, or the failure to enter into such Contract and give such Bond within the time specified, if the Principal shall pay the County the difference between the amount specified, in said Bid and the amount for which the County may procure the required Work and supplies, if the latter amount be in excess of the former, then the above obligations shall be void and of no effect, otherwise to remain in full force and virtue.

IN WITNESS WHEREOF, the above bounded parties have executed this instrument under their several seals, this 21st day of July A.D., 20 21, the name and corporate seal of each corporate party being hereto affixed and these presents duly signed by its undersigned representative, pursuant to authority of its governing body.

BID NO.: 21-101

WITNESSES:

(If Sole Ownership or Partnership two (2) Witnesses required).
(If Corporation, Secretary only will attest and affix seal).

WITNESSES:

Chinchor Electric, Inc. Timothy J. Chinchor
PRINCIPAL:

Chinchor Electric, Inc.
NAME OF FIRM:

[Signature]
SIGNATURE OF AUTHORIZED
OFFICER (AFFIX SEAL)

President
TITLE

1460 S. Leavitt Avenue
BUSINESS ADDRESS

Orange City, FL 32763
CITY STATE

United Fire & Casualty Company
SURETY:

United Fire & Casualty Company
CORPORATE SURETY

Teresa L. Durham
ATTORNEY-IN-FACT (AFFIX SEAL)
& FL Licensed Resident Agent, Teresa L. Durham*
PO Box 73909
BUSINESS ADDRESS

Cedar Rapids, IA 52407-3909
CITY STATE

*Florida Surety Bonds, Inc. 407-786-7770
NAME OF LOCAL INSURANCE AGENCY

WITNESS:

Jenna Delgado
Jenna Delgado

UNITED FIRE AND CASUALTY COMPANY

P.O. Box 73909, Cedar Rapids, IA. 52407

Statement of Financial Condition
As Of December 31, 2020

ASSETS

Bonds	\$802,039,910
Stocks	479,001,640
Real Estate and Equipment	42,759,356
Cash in Banks and Offices and Short Term Investments	161,593,676
Premiums in Course of Collection (less than 90 days-old)	337,918,023
Reinsurance and Other Accounts Receivable	53,809,652
Deposits and Other Non Invested Assets	138,436,096
Total Admitted Assets	<u>\$2,015,558,353</u>

LIABILITIES, SURPLUS AND OTHER FUNDS

Reserve for Unearned Premiums	\$289,369,670
Reserve for Claims and Claim Expense	992,102,435
Reserve for Taxes and Expense	62,486,927
Total Liabilities	<u>\$1,343,959,032</u>
Capital Stock and Paid In Capital	\$214,332,965
Surplus Notes	50,000,000
Surplus	407,266,356
Surplus as regards Stockholders	671,599,321
Total	<u>\$2,015,558,353</u>

Securities carried at \$7,367,791 in the above statement are deposited as required by law.

Securities carried on the basis prescribed by the National Association of Insurance Commissioners. On the basis of December 31, 2020 market quotations for all bonds and stocks owned, the Company's total admitted assets would be \$2,015,558,353 and surplus as regards shareholders \$671,599,321.

I, Janice A. Martin, Treasurer of United Fire and Casualty Company, do hereby certify that the foregoing statement is a correct exhibit of the assets and liabilities of the said Company on the 31st day of December, 2020

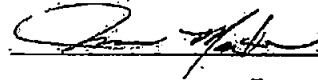
Treasurer

State of Iowa
City of Cedar Rapids } SS:

Subscribed and sworn to, before me, a Notary Public of the State of Iowa in the City of Cedar Rapids, this 4th day of March, 2021

Notary Public

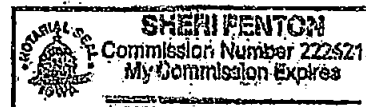



UNITED FIRE & CASUALTY COMPANY, CEDAR RAPIDS, IA
 UNITED FIRE & INDEMNITY COMPANY, WEBSTER, TX
 FINANCIAL PACIFIC INSURANCE COMPANY, ROCKLIN, CA
 CERTIFIED COPY OF POWER OF ATTORNEY

Inquiries - Surety Department
 118 Second Ave SE
 Cedar Rapids, IA 52401

(original on file at Home Office of Company - See Certification)

KNOW ALL PERSONS BY THESE PRESENTS, That United Fire & Casualty Company, a corporation duly organized and existing under the laws of the State of Iowa; United Fire & Indemnity Company, a corporation duly organized and existing under the laws of the State of Texas; and Financial Pacific Insurance Company, a corporation duly organized and existing under the laws of the State of California (herein collectively called the Companies), and having their corporate headquarters in Cedar Rapids, State of Iowa; does make, constitute and appoint:

KIM E. NIV, JEFFREY W. REICH, SUSAN L. REICH, TERESA L. DURHAM, GLORIA A. RICHARDS, LISA ROSELAND, SONJA AMANDA FLOREE HARRIS, CHERYL FOLEY, ROBERT P. O'LINN, SARAH K. O'LINN, EACH INDIVIDUALLY

their true and lawful Attorney(s)-in-Fact with power and authority hereby conferred to sign, seal and execute in its behalf all lawful bonds, undertakings and other obligatory instruments of similar nature provided that no single obligation shall exceed \$100,000,000.00 and to bind the Companies thereby as fully and to the same extent as if such instruments were signed by the duly authorized officers of the Companies and all of the acts of said Attorney, pursuant to the authority hereby given and hereby ratified and confirmed.

The Authority hereby granted is continuous and shall remain in full force and effect until revoked by United Fire & Casualty Company, United Fire & Indemnity Company, and Financial Pacific Insurance Company.

This Power of Attorney is made and executed pursuant to and by authority of the following bylaw duly adopted on May 15, 2013, by the Boards of Directors of United Fire & Casualty Company, United Fire & Indemnity Company, and Financial Pacific Insurance Company.

"Article VI - Surety Bonds and Undertakings"

Section 2, Appointment of Attorney-in-Fact. "The President or any Vice President, or any other officer of the Companies may, from time to time, appoint by written certificate attorneys-in-fact to act in behalf of the Companies in the execution of policies of insurance, bonds, undertakings and other obligatory instruments of like nature. The signature of any officer authorized hereby, and the Corporate seal, may be affixed by facsimile to any power of attorney or special power of attorney or certification of either authorized hereby; such signature and seal, when so used, being adopted by the Companies as the original signature of such officer and the original seal of the Companies, to be valid and binding upon the Companies with the same force and effect as though manually affixed. Such attorneys-in-fact, subject to the limitations set of forth in their respective certificates of authority shall have full power to bind the Companies by their signature and execution of any such instruments and to attach the seal of the Companies thereto. The President or any Vice President, the Board of Directors or any other officer of the Companies may at any time revoke all power and authority previously given to any attorney-in-fact.

IN WITNESS WHEREOF, the COMPANIES have each caused these presents to be signed by its vice president and its corporate seal to be hereto affixed this 11th day of October, 2013



UNITED FIRE & CASUALTY COMPANY
 UNITED FIRE & INDEMNITY COMPANY
 FINANCIAL PACIFIC INSURANCE COMPANY

By: *Dennis J. Richmann*
 Vice President

State of Iowa, County of Linn, ss:

On 11th day of October, 2013, before me personally came Dennis J. Richmann to me known, who being by me duly sworn, did depose and say, that he resides in Cedar Rapids, State of Iowa; that he is a Vice President of United Fire & Casualty Company, a Vice President of United Fire & Indemnity Company, and a Vice President of Financial Pacific Insurance Company the corporations described in and which executed the above instrument; that he knows the seal of said corporations; that the seal affixed to the said instrument is such corporate seal that it was so affixed pursuant to authority given by the Board of Directors of said corporations and that he signed his name thereto pursuant to like authority, and acknowledges same to be the act and deed of said corporations.

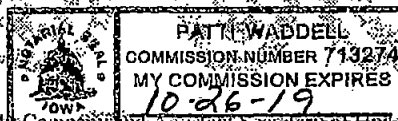

Patti Waddell
 Notary Public
 My commission expires: 10-26-19

I, Mary A. Bertsch, Assistant Secretary of United Fire & Casualty Company and Assistant Secretary of Financial Pacific Insurance Company, do hereby certify that I have compared the foregoing copy of the Power of Attorney and affidavit and the copy of the Section of the bylaws and resolutions of said Corporations as set forth in said Power of Attorney, with the ORIGINALS ON FILE IN THE HOME OFFICE OF SAID CORPORATIONS, and that the same are correct transcripts thereof, and of the whole of the said originals, and that the said Power of Attorney has not been revoked and is now in full force and effect.

In testimony whereof I have hereunto subscribed my name and affixed the corporate seal of the said Corporations this 21st day of July, 20 21.



By: *Mary A. Bertsch*
 Assistant Secretary
 UFGI & UFI & FPIC

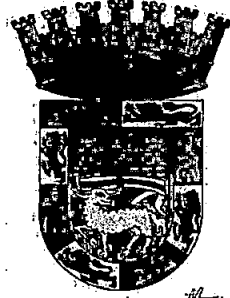

**ST. JOHNS COUNTY
BOARD OF COUNTY COMMISSIONERS**

BID NO: 21-101

**SIGNALIZATION REPLACEMENT AT INTERSECTION OF
US 1 / LEWIS POINT ROAD / ST. AUGUSTINE SOUTH DRIVE
– HMGP 4283-011-R**

**St. Johns County Purchasing Department
500 San Sebastian View
St. Augustine FL 32084
(904) 209-0150
www.sjcfcl.us/Purchasing/index.aspx**

**BID NO: 21-101; SIGNALIZATION REPLACEMENT AT INTERSECTION OF US 1 / LEWIS POINT ROAD /
ST. AUGUSTINE SOUTH DRIVE – HMGP 4283-011-R**

TABLE OF CONTENTS

FRONT END BID DOCUMENTS

Notice to Bidders
Instruction to Bidders
Hazard Mitigation Grant Program (HMGP) Required Contract Clauses
Official County Bid Form

Attachments:

- “A” – St Johns County Board of County Commissioners Affidavit
 - “B” – Certificate as to Corporate Principal
 - “C” – License/Certification List
 - “D” – List of Proposed Sub-Contractors/Suppliers
 - “E” – Conflict of Interest Disclosure Form
 - “F” – Drug-Free Workplace Form
 - “G” – Proof of Insurance
 - “H” – Experience of Bidder Form
 - “I” – Claims, Liens, Litigation History
 - “J” – E-Verify Affidavit
 - “K” – Certificate of Compliance with Florida Trench Safety Act
 - “L” – Public Entity Crimes Statement
 - “M” – Debarment, Suspension, Ineligibility, Voluntary Exclusion Form
 - “N” – Certification for Disclosure of Lobbying Activities
 - “O” – Unit Prices for Adjustments/Schedule of Values
- Bid Bond

SPECIFICATIONS

**EXHIBIT A – REPORT OF GEOTECHNICAL EXPLORATION TRAFFIC SIGNAL MAST ARM DESIGN –
(SEPARATE ATTACHMENT)**

EXHIBIT B – SIGNALIZATION PLANS – (SEPARATE ATTACHMENT)

SEALED BID MAILING LABEL

END OF TABLE OF CONTENTS

BID NO: 21-101**NOTICE TO BIDDERS**

Notice is hereby given that sealed bids will be received **until 2:00 P.M. (EDST) on Wednesday, July 21, 2021** by the St. Johns County Purchasing Department, located at 500 San Sebastian View, St. Augustine, Florida 32084 for **Bid No: 21-101; Signalization Replacement at Intersection of US 1 / Lewis Point Road / St. Augustine South Drive – HMGP 4283-011-R.** Bids will be opened promptly after the 2:00 P.M. deadline. **Note:** Bids delivered to or received by the Purchasing Department after the 2:00 P.M. deadline shall not be given consideration and shall be returned to the sender unopened.

The Contractor shall be responsible for providing any and all labor, materials, and equipment required for replacement of signalization at the intersection of US 1 (SR 5) and Lewis Point Road/St. Augustine South Drive. This project includes replacing the existing strain pole and span wire signals with mast arms. All existing signal equipment, including the strain poles and span wires, will need to be removed and new signal equipment will need to be installed. This includes the installation of one mast arm on each corner, for a total of four mast arms. The intersection is to remain fully signalized throughout construction. In addition, this project includes the installation of new pedestrian features on each corner of the intersection. Miscellaneous improvements (lighting, conduit, pull boxes, controller cabinet, vehicle detection, etc.) will also be required.

Funding for this project is through the Hazard Mitigation Grant Program (HMGP) as approved by the Florida Division of Emergency Management (Division) and the Federal Emergency Management Agency (FEMA).

The FEMA project number is HMGP 4283-011-R, funded under FEMA-DR-4283-FL.

Prime Bidder must be fully licensed to do business in the State of Florida. The prime or sub-contractor performing the work must be currently Florida Department of Transportation (FDOT) pre-qualified in Work Class 39 – Traffic Signal and a letter from FDOT confirming pre-qualification in the required work class must be submitted with the sealed bid proposal. Bidders must have successfully completed at least three (3) projects, in the past ten (10) years, equal to or greater than the scope and dollar value of that being proposed.

Copies of current licenses and certifications for the Prime Bidder, Sub-Contractor, must be provided with the submitted Bid Proposal.

Bid Documents related to this bid may be obtained from DemandStar, Inc., at the following web address: www.demandstar.com by requesting St. Johns County Bid Document # **21-101**. For technical assistance with this Website please contact DemandStar Supplier Services at 1-866-273-1863. A link to the DemandStar website is available through the St. Johns County Purchasing Website by clicking on the following link: <http://www.sjcfl.us/Purchasing/index.aspx> Check the County's site for download availability and any applicable fees. Bid Documents may also be requested, in writing, from Diana M. Fye, AS, CPPB, Procurement Coordinator, St. Johns County Purchasing, via email to dfye@sjcfl.us or fax to (904) 209-0163.

The County's Designated Point of Contact for this Bid is Diana M. Fye, AS, CPPB, Procurement Coordinator, St. Johns County Purchasing Department. Any and all questions and/or inquiries shall be directed to Ms. Fye, *in writing*, via email at dfye@sjcfl.us or fax to (904) 209-0163. In the event the Designated Point of Contact is absent or otherwise unavailable for more than three (3) business days, firms may contact Leigh A. Daniels, CPPB, Purchasing Manager at ldaniels@sjcfl.us.

Vendors shall not contact, lobby, or otherwise communicate with any SJC employee, including any member of the Board of County Commissioners, other than the above referenced individual from the point of advertisement of the Bid until contract(s) are executed by all parties, per SJC Purchasing Code 304.6.5 "Procedures Concerning Lobbying". According to SJC policy, any such communication shall disqualify the vendor, contractor, or consultant from responding to the subject invitation to bid, request for quote, request for proposal, invitation to negotiate, or request for qualifications.

Any and all questions related to this project shall be directed, *in writing*, to the Designated Point of Contact. Questions are due no later than four o'clock (4:00PM) EDST on **Wednesday, June 30, 2021**, so that any necessary addenda may be issued in a timely manner. Any questions received after the deadline will not be answered unless previously approved by the SJC Purchasing Manager or other designated County Representative.

Any bidder, proposer or person substantially and adversely affected by an intended decision or by an term, condition, procedure or specification with respect to any bid, invitation, solicitation of proposals or requests for qualifications, shall file with the Purchasing Department for St. Johns County, a written notice of intent to protest no later than 72 hours (excluding Saturdays, Sundays and legal holidays for employees of St. Johns County) after the posting either electronically or by other means of the notice of intended action, notice of intended award, bid tabulation, publication by posting electronically or by other means of a procedure, specification, term or condition which the person intends to protest, or the right to protest such matter shall be waived. The protest procedures may be obtained from the Purchasing Department and are included in the County's Purchasing Manual.

All of the terms and conditions of the County Purchasing Manual are incorporated by reference and are fully binding.

St. Johns County reserves the right to accept or reject any or all bids/proposals, waive minor formalities, and to award the bid/proposal that best serves the interests of St. Johns County. St. Johns County also reserves the right to award the base bid and any alternate bids in any combination that best suits the needs of the County.

BOARD OF COUNTY COMMISSIONERS
OF ST. JOHNS COUNTY, FLORIDA
BRANDON J. PATTY, CLERK OF THE CIRCUIT COURT & COMPTROLLER

BY: _____
Deputy Clerk

BID NO.: 21-101

FRONT END BID DOCUMENTS

BID NO: 21-101

INSTRUCTION TO BIDDERS

OWNER: The Board of County Commissioners of St. Johns County, Florida (“County”)

PROJECT: BID NO: 21-101; Signalization Replacement at Intersection of US 1 / Lewis Point Road / St. Augustine South Drive – HMGP 4283-011-R

DEFINITIONS

All definitions set forth in the General Conditions of the Contract or in other Contract Documents are applicable to the Bidding Documents.

Addenda are written or graphic instruments issued by the Purchasing Department prior to the time and date for receiving Bids that modify or interpret the Bidding Documents by addition, deletion, clarification, or corrections.

Base Bid is complete and properly signed proposal to do the work, or designated portion thereof, for the sums stipulated therein supported by data called for by the Bidding Documents.

Bid An offer, as a price, whether for payment or acceptance. A quotation, specifically given to a prospective purchaser upon its request, usually in competition with other vendors

Bid (Formal or Sealed) A request for firm prices by Advertised Legal Notice. Prices are submitted in sealed envelopes and in conformance with a prescribed format, all of which are opened in public on an appointed hour and date as advertised.

Bid Bond A good faith monetary commitment which a bidder or surety forfeits to the County if the bidder refuses, or is unable to enter into a contract after submitting a bid, or the bidder cannot furnish the required bonds, usually five percent (5%) of the bid proposal price.

Bidder is a firm or individual who submits a Bid to the Owner for the work described in the proposed Contract Documents.

Bidding Documents include the Advertisement/Notice to Bidders, Front End Bid Documents, Contract Agreement, Specifications and Plans including any Addenda issued prior to receipt of Bids.

Contract A delivered agreement between two or more parties, legally binding and enforceable, to perform a specific act or acts or exchange goods for consideration. A purchase order becomes a contract when accepted by a vendor. A unilateral contract is one in which only one party promises performance. A bilateral contract is one in which both parties promise performance.

Contractor An individual or firm having a contract to provide goods, service or construction for a specified price

County St. Johns County, a political subdivision of the State of Florida (F.S. 217.73)

Responsible Bidder A bidder capable of performing in all respects to fulfill the contract requirements. This includes having the ability to perform, the experience, reliability, capacity, credit, facilities and equipment to meet the contractual obligation.

Responsive Bid, Responsive Proposal, or Responsive Reply A bid, proposal, or reply submitted by a responsive and responsible vendor conforming in all material respects to the solicitation.

Specifications A clear, complete and accurate statement of the physical, functional or technical requirements descriptive of an item and if applicable, the procedure to be followed to determine if the requirements are met.

Subcontractor A party who contracts with a prime contractor to perform all or any part of the prime contractor's obligations.

Unit Price is an amount stated in the Bid as a price per unit of measurement for materials or services as described in the

contract documents which shall include all labor, materials, equipment and any other item/s essential to accomplish the scope of work of the Unit Price.

BIDDER'S REPRESENTATION

Each Bidder, by marking his Bid, represents that he has read and understands the Bidding and Contract Documents and his Bid is made in accordance herewith: he has visited the Site and has familiarized himself with the local conditions under which the Work is to be performed; and his Bid is based upon the materials, systems and equipment described in the Bidding Documents without exceptions.

BIDDING DOCUMENTS

Bidding documents may be obtained from www.demandstar.com or SJC Purchasing, in the number and for the purchase sum, if any, as stated in the Advertisement or Invitation - Notice to Bidders. Complete sets of Bidding Documents shall be used in preparing the Bid Proposal. St. Johns County shall not assume any responsibility for errors or misinterpretations resulting from the use of complete or incomplete sets of Bidding Documents. The Owner, in making copies of the Bidding Documents available on the above terms, do so only for the purpose of obtaining bids on the Work and do not confer a license or grant for any other use.

INTERPRETATION OR CORRECTION OF BIDDING DOCUMENTS

Bidders shall promptly notify the Owner of any ambiguity, inconsistency, or error which they may discover upon examination of the Bidding Documents or of the site and local conditions. Bidders requiring clarification of interpretation of the Bidding Documents shall make a written request to the Owner, to reach him at least **fourteen (14) days** prior to the date for receipt of Bids.

An interpretation, correction, or change of the bidding Documents will be made by Addendum. Interpretation, corrections, or changes of the Bidding Documents made in any other manner will not be binding, and Bidders shall not rely upon such interpretation, corrections, and change. No change will be made to the Bidding Documents by the Owner or its Representative **seven (7) days** prior to Bid receiving date, however, the Owner reserves the authority to decrease this time depending on the necessity of such change.

SUBSTITUTIONS

The materials, products and equipment described in the Bidding Documents establish a standard of required function, dimension, appearance and quality to be met by any proposed substitution. No substitution will be considered unless written request for approval has been submitted by the Bidder and has been received by the Owner at least **fourteen (14) days** prior to the date for receipt of Bids. Each such request shall include the name of the material or equipment for which it is to be substituted and a complete description of the proposed substitute, including drawings, cuts, performance and test data any other information necessary for an evaluation. A statement setting forth any changes in other materials, equipment or work that incorporation of the substitute would require shall be included. The burden of proof of the merit of the proposed substitute is upon the proposer. The project director's approval or disapproval of a proposed substitution shall be final.

If County Staff approves any proposed substitution, such approval will be set forth in an Addendum. Bidders shall **not** rely upon approval made in any other manner.

DESIGNATED POINT OF CONTACT

The County's Designated Point of Contact for this Bid is Diana M. Fye, AS, CPPB, Procurement Coordinator, St. Johns County Purchasing Department. Any and all questions and/or inquiries shall be directed to Ms. Fye, *in writing*, via email at dfye@sjcfl.us or fax to (904) 209-0163. In the event the Designated Point of Contact is absent or otherwise unavailable for more than three (3) business days, firms may contact Leigh A. Daniels, CPPB, Purchasing Manager at ldaniels@sjcfl.us.

Vendors shall not contact, lobby, or otherwise communicate with any SJC employee, including any member of the Board of County Commissioners, other than the above referenced individual from the point of advertisement of the Bid until contract(s) are executed by all parties, per SJC Purchasing Code 304.6.5 "Procedures Concerning Lobbying". According to SJC policy, any such communication shall disqualify the vendor, contractor, or consultant from responding to the subject invitation to bid, request for quote, request for proposal, invitation to negotiate, or request for qualifications. St. Johns County reserves the right to accept or reject any or all bids/proposals, waive minor formalities, and to award the bid/proposal that best serves the interests of St. Johns County. St. Johns County

also reserves the right to award the base bid and any alternate bids in any combination that best suits the needs of the County.

QUESTIONS

Any and all questions related to this project shall be directed, *in writing*, to the Designated Point of Contact. Questions are due no later than four o'clock (4:00PM) EDST on **Wednesday, June 30, 2021**, so that any necessary addenda may be issued in a timely manner. Any questions received after the deadline will not be answered unless previously approved by the SJC Purchasing Manager or other designated County Representative.

ADDENDA

Addenda will be distributed to all who are known by the entity responsible for distribution of the complete set of Bidding Documents. Copies of Addenda will be made available for inspection wherever Bidding Documents are on file for that purpose.

Each Bidder shall ascertain prior to submitting a bid, that all issued addenda have been received, and each Bidder **shall** acknowledge receipt, of all issued addenda in the space provided in the Official County Bid Form, and a fully acknowledged copy of each issued addendum must be included in the submitted bid proposal. Failure to provide fully acknowledged copies of each addendum may result in a bid proposal being deemed non-responsive.

FORM AND STYLE OF BIDS

Bids shall be submitted in **TRIPPLICATE (one (1) original and two (2) copies)** on the required forms provided herein. All blanks on the Bid Form shall be filled in by typewriter or manually in blue or black ink. Bidders are not required to submit a copy of this Bid Document with their bid proposals. The bidders are required to submit, at a minimum, the Bid Proposal Attachments listed in this Document.

Bid proposals must be placed in an envelope, sealed and placed in a second envelope or container, plainly marked on the outside addressed to St. Johns County Purchasing Department, with the bidder's return address in top left hand corner and recite: **"BID NO: 21-101; Signalization Replacement at Intersection of US 1 / Lewis Point Road / St. Augustine South Drive – HMGP 4283-011-R."**

See Example Below:

ABC Company, Inc. 123 Aviles Street St. Augustine, FL 32084	St. Johns County Purchasing Department 500 San Sebastian View St. Augustine, FL 32084 BID NO.: XX-XX – SEALED BID FOR SAMPLE PROJECT
---	--

At the end of this document, a sealed Bid mailing label is provided for convenience. Bidders shall affix the provided label to the outside of the sealed envelope/container to submit their Bid.

Bidder shall assume full responsibility for timely delivery at location designated for receipts of Bids. Bids shall be deposited at the designated location prior to the time and date for receipt of Bids indicated in the Advertisement/Notice to Bidders, or any time extension thereof made by Addendum. Bids received after the time and date for receipt of Bids will be returned to the sender unopened.

Oral, telephonic, telegraphic or electronic Bids are invalid and will not receive consideration.

Where so indicated by the makeup of the Bid Form, sums shall be expressed in both words and figures, and in the case of discrepancy between the two, the amount expressed in words shall govern. Any interlineations, alteration or erasure must be initialed by the signer of the Bid, failure to do so may cause the Bidder's proposal to be considered non-responsive.

Any interlineations, alteration or erasure must be initialed by the signer of the Bid; failure to do so may cause the Bidder's proposal to be considered non-responsive.

Bidder shall make no stipulation on the Bid Form nor qualify his Bid in any manner, to do so will classify the Bid as being non-responsive.

A Delegation of Authority must be submitted for any representative signing a submitted bid proposal, who is not a principal, officer, or owner of the bidding company.

A Bid submitted by an agent shall have a current Power of Attorney attached certifying agent's authority to bind the Bidder.

Each copy of the Bid Proposal shall include the company name, address, telephone number and legal name of Bidder and a statement whether Bidder is sole proprietor, a partnership, a corporation or any other legal entity. Each copy shall be signed by the person or persons legally authorized to bind the Bidder to a contract. A Bid by a corporation shall further give the state of incorporation and have the corporation seal affixed.

BID SECURITY

Each submitted Bid shall be accompanied by a Bid Security, submitted on the Bid Bond Form provided herein, or in the form of a certified or cashier's check, in the amount of five percent (5%) of the Total Lump Sum Bid amount submitted on the Official County Bid Form, pledging that the Bidder will enter into a contract with the Owner on the terms stated in the Bid and will, if required, furnish bonds as described hereunder covering the faithful performance of the Contract and the payment of all obligations arising thereunder. Should the Bidder refuse to enter into such Contract or fail to furnish such bonds to the Owner, if required, the amount of the Bid Security shall be forfeited, not as penalty, but as liquidated damages.

A Bid Security in the form of a certified or cashier's check must be made payable to the Board of County Commissioners of St. Johns County. Bidders submitting a certified or cashier's check as the bid security are not required to submit **Attachment "B"** – Certificate as to Corporate Principal, or the Bid Bond forms provided herein.

A Bid Security in the form of a Bid Bond shall be written on the form provided herein, with an acceptable surety, and the Attorney-in-Fact who executes the bond on behalf of the surety shall affix to the bond a certified and current copy of his Power of Attorney. Acceptable surety companies are defined herein under "Surety Bond". The Surety Company shall be licensed to do business in the State of Florida and shall be listed by the U.S. Treasury Department. Any Bidder submitting a Bid Security in the form of a Bid Bond must also submit **Attachment "B"** – Certificate as to Corporate Principal.

The Owner shall have the right to retain the Bid Security of Bidders until either: (a) the Contract is executed and bonds, if required, have been furnished, or (b) the specified time has elapsed so that Bids may be withdrawn, or (c) all Bids have been rejected.

BID BOND INSTRUCTIONS

If a Bidder chooses to submit a Bid Bond on the form provided herein, he must submit the bond as follows:

1. Prepare and submit one (1) original and two (2) copies of the required Bid Bond Forms as shown above
2. Type or print Bidder's and Surety's names in the same language as in the Advertisement, or Invitation to Bid.
3. Affix the Corporate Seal, and type or print the name of the Surety on the line provided and affix its corporate seal.
4. Attach a copy of Surety agent's Power of Attorney, unless the Power of Attorney has been recorded in St. Johns County. If it has been recorded, give the record book and page. If not recorded, the copy of the Power of Attorney must have an original signature of the Secretary or Assistant Secretary of Surety certifying the copy. The Surety's corporate seal must be affixed.

BID POSTPONEMENT/CANCELLATION

The County may, at its sole and absolute discretion, reject any bids that are not submitted in accordance with the terms in this Bid Solicitation. The County may re-advertise this Bid; postpone or cancel, at any time, this Bid process; or waive any irregularities in this Bid or in the proposals received as a result of this Bid.

MODIFICATION OR WITHDRAWAL OF BID

A Bid may not be modified, withdrawn or canceled by the Bidder during the stipulated time period following the time and date designated for the receipt of Bids, and Bidder so agrees in submitting his Bid.

Prior to time and date designated for receipt of Bids, a Bid submitted early may be modified or withdrawn only by notice to the party receiving Bids at the place and prior to the time designated for receipt of Bids.

Such notice shall be in writing over the signature of the Bidder. If by telephone, written confirmation over the signature of Bidder must be mailed and postmarked on or before the date and time set for receipt of Bids; it shall be so worded as not to reveal the amount of the original Bid.

Withdrawn Bids may be resubmitted up to the time designated for the receipt of Bids provided that they are then fully in conformance with these Instructions to Bidders.

COSTS INCURRED BY BIDDERS

All expenses involved with the preparation and submission of bids to the County, or any work performed in connection therewith, shall be borne by the Bidder(s). No rights of ownership will be conferred until title of the property is transferred to the successful bidder. All fees for copying and reproduction services for items listed herein are nonrefundable.

CONSIDERATION OF BIDS

Opening of Bids: Unless stated otherwise in an Addenda to the Advertisement/Notice to Bidders, the properly identified Bids received on time will be opened publicly as specified in the Advertisement and a tabulation of the bid amounts of the Base Bids and major Alternates, if any, will be made available to Bidders. The Bid Tabulation will be posted on the Purchasing Department bulletin board for seventy two (72) hours.

Any bidder, proposer or person substantially and adversely affected by an intended decision or by a term, condition, procedure or specification with respect to any bid, invitation, solicitation of proposals or requests for qualifications, shall file with the Purchasing Department for St. Johns County, a written notice of intent to protest no later than seventy two (72) hours (excluding Saturdays, Sundays and legal holidays for employees of St. Johns County) after the posting either electronically or by other means of the notice of intended action, not of intended award, bid tabulation, publication by posting electronically or by other means of a procedure, specification, term or condition which the person intends to protest, or the right to protest such matter shall be waived. The protest procedures may be obtained from the Purchasing Department and are included in the County's Purchasing Manual. All of the terms and conditions of the County Purchasing Manual are incorporated by reference and are fully binding.

Vendors shall not contact, lobby, or otherwise communicate with any SJC employee, including any member of the Board of County Commissioners, other than the above referenced individual from the point of advertisement of the Bid until contract(s) are executed by all parties, per SJC Purchasing Code 304.6.5 "Procedures Concerning Lobbying". According to SJC policy, any such communication shall disqualify the vendor, contractor, or consultant from responding to the subject invitation to bid, request for quote, request for proposal, invitation to negotiate, or request for qualifications.

Rejection of Bids: The County reserves the right to reject any or all Bids and in particular to reject a Bid not accompanied by any required Bid Security or data required by the Bidding Documents or a Bid in any way incomplete or irregular.

Acceptance of Bid (Award): The County shall have the right to reject any or all Bids or waive any minor formality or irregularity in any Bid received. If the Contract is awarded, it will be awarded within a minimum of ninety (90) days from the date of the Bid opening, or as designated in the Bid Documents.

It is the intent of the County to award a contract to the vendor who submits the lowest responsive, responsible Bid on the basis of the lump sum price, provided the Bid has been submitted in accordance with the requirements of the Bidding Documents, if judged to be reasonable, does not exceed the funds budgeted for the Work and is deemed to be in the best interest of the County.

The County may consider award to multiple vendors, if awarding multiple contracts is more cost effective than awarding a single contract based on pricing for the County as a whole.

LOCAL PREFERENCE

While the County has a Local Preference Policy, this project is funded through the Hazard Mitigation Grant Program (HMGP), which prohibits the use of local preference in the consideration for award, as provided in 2 C.F.R. §200.319(b) and in Florida Statute §255.0991. The SJC Purchasing Procedural Manual, Section 302.25 allows the County to waive the use of local preference in such circumstances.

QUALIFICATION OF CONTRACTORS

Minimum Qualifications:

1. Prime Bidder must be fully licensed to do business in the State of Florida.
2. Prime bidders are required to provide proof of any and all certifications and licenses required by Federal, State, and/or County law, rule, regulation or ordinance in the submitted bid.
3. The prime or sub-contractor performing the work shall be currently Florida Department of Transportation (FDOT) pre-qualified in Work Class 39 – Traffic Signal. A letter from FDOT confirming pre-qualification of the Contractor in the required work class must be submitted with the bid.
4. Bidders must have successfully completed, as a Prime or Sub-contractor, at least three (3) projects, in the past ten (10) years, equal to or greater than the scope and dollar value of that being proposed herein. Minimum experience requirement must be met by the Prime Bidder and not the proposed sub-contractor for this project. The County reserves the right to consider additional or alternate projects as proof of qualifications.

Proof of minimum qualifications shall be provided by completing and submitting **Attachment “C”** – License/Certification List along with a copy of each license and certificate listed, and by completing and submitting **Attachment “H”** – Experience of Bidder form with the submitted bid. All licenses, certifications and pre-qualifications must be valid and current on the date bids are submitted.

Those who have been placed on the convicted vendor list following a conviction for a public entity crime or on the discriminatory vendor list may not submit a bid on a contract to provide any goods or services of a public building or public work, may not submit bids on leases of real property to a public entity, may not be awarded or perform work as a contractor, supplier, subcontractor, or consultant under a contract with a public entity, and may not transact business with any public entity in excess of \$25,000.00 for a period of 36 months from the date of being placed on the convicted vendor list or on the discriminatory vendor list.

Bidders who are debarred or suspended at the time of Bid opening are not eligible and will be deemed unresponsive and unresponsive for this federally funded project. Bidders who have been placed on the convicted vendor list following a conviction for a public entity crime or on the discriminatory vendor list may not submit a bid proposal for this Bid. Bidders must provide an executed “Debarment, Suspension, Ineligibility, Voluntary Exclusion Form” as the prospective Sub-Contractor of the Grant Recipient (St. Johns County) performing services for this project, by completing and submitting **Attachment “L”** with the submitted bid proposal.

SUB-CONTRACTORS

Each Bidder shall submit to the County, a list of Subcontractors and major materials suppliers to be used if awarded the contract. A copy of the form, **Attachment “D”**, is provided in the Bidding Documents. If no Subcontractors or major material suppliers are required, so state there on.

Upon request by the County, the successful Bidder shall within seven (7) days thereafter, submit all data required to establish to the satisfaction of the County, the reliability and responsibility of the proposed Subcontractors to furnish and perform the work described in the Sections of the Specifications pertaining to such proposed Subcontractor’s respective trades.

Prior to the award of the Contract, the County will notify the Bidder in writing if either the County, after due investigation, has reasonable and substantial objection to any person or organization proposed as a Subcontractor. The Bidder then may, at his option, withdraw his Bid without forfeiture of Bid Security or submit an acceptable substitute at no increase in Bid price. If the Bidder fails to submit an acceptable substitute within seven (7) days of the original notification, the County then may, at his option, disqualify the Bidder, at no cost to the County.

The County reserves the right to disqualify any Contractor, Subcontractor, Vendor, or material supplier due to previously documented project problems, either with performance or quality.

Subcontractors and other persons and organizations proposed by the Bidder and accepted by the County, must be used on the work for which they were proposed and accepted and shall not be changed except with the written approval of the County.

FLORIDA TRENCH SAFETY ACT

Bidders shall complete Certificate of Compliance with Florida Trench Safety Act, in accordance with the requirements of Chapter 553, Florida Statutes. If trenching is not required for this project, state so thereon. Contractor shall be responsible for compliance with all trenching shoring safety requirements.

PUBLIC CONSTRUCTION BOND

The Contractor shall be required to obtain and submit a recorded Public Construction Bond covering the faithful performance of the Contract and the payment of all obligations arising thereunder in full amount of the Contract, with such acceptable sureties, secured through the Bidder's usual sources as may be agreeable to the parties. The Contractor shall furnish the required bond, after full execution of the awarded Contract. The Bond shall be released upon satisfactory completion of the project.

SURETY BOND

Acceptable Surety Companies: To be responsible to the Owner as Surety on Bonds, Surety shall comply with the following provisions:

1. Surety must be licensed to do business in the State of Florida;
2. Surety must have been in business and have a record of successful continuous operations for at least three (3) years;
3. Surety shall not have exposed itself to any loss on any one risk in an amount exceeding twenty percent (20%) of its surplus to policyholders;
4. Surety must have fulfilled all of its obligations on all other bonds given to the Owner;
5. Surety must have good underwriting, economic management, adequate reserves for undisclosed liabilities, and net resources for unusual stock and sound investment.

Time of Delivery and Form of Bonds

The Public Construction Bond form will be forwarded to the successful Bidder with his copy of the fully executed contract. **The Public Construction Bond must be recorded after the contract is signed by all parties.** The bidder will have 3 days from receipt of fully executed contract to have the Public Construction Bond recorded. The bidder shall have the Public Construction Bond recorded at the St. Johns County Clerk of Courts office, in St. Augustine, Florida. After the book and page number have been assigned to the bond by the recording person, the Bidder is to obtain from the recording person a certified copy of the recorded bond, and deliver the certified copy to the Owner's Contract Administrator. No work can commence until the required bond and Insurance Certificates have been delivered to the Owner. Upon receipt of the certified copy of the recorded bond, the Owner may issue a Notice to Proceed.

Unless otherwise specified in the Bid Documents, the bonds shall be written on the form provided herein. The Bidder shall require the Attorney-in-Fact who executes the required bonds on behalf of the Surety to affix thereto a certified and current copy of his Power of Attorney authorizing his firm to act as agent for the Surety in issuing the bonds.

FORM OF AGREEMENT BETWEEN OWNER AND CONTRACTOR

Form to be used: Unless otherwise provided in the Bidding Documents, the Agreement for Work will be written on the St. Johns County Standard Agreement between Owner and Contractor where the basis of payment is a Stipulated Sum. In the event of a conflict in specifications or contract requirements the more stringent shall apply.

EXECUTION OF CONTRACT DOCUMENTS

The awarded Contractor shall return signed copies of the Contract Agreement to the SJC Purchasing Department within ten (10) consecutive calendar days of receipt of Notice of Award. St. Johns County shall return a fully executed original copy of the Contract Agreement to the Contractor no later than seven (7) consecutive calendar days after the return of the signed copies from the Contractor.

CONTRACT TIME – LIQUIDATED DAMAGES

The Contractor shall have ten (10) days to return Contract originals from the time the Contractor receives a "Notice of Award". St. Johns County will return a "fully executed" Contract to the Contractor no later than seven (7) days after the return of the executed Contract originals (but no later than seventeen (17) days from the Notice of Award).

The Contractor will furnish a recorded original of the Public Construction Bond three (3) business days after receipt of the fully executed Contract (the Public Construction Bond must be recorded after the Contract is fully executed by all parties including

the County Clerk). Upon receipt of the recorded Public Construction Bond, the County will issue a Notice to Proceed. If the Contractor fails to meet any of the dates and timeframes set forth in this section, or fails to execute the Contract, or to provide a Public Construction Bond, the County may elect at its option to consider the Contractor non-responsive and Contract with the next best Bidder.

The work to be performed under this Agreement shall be commenced within **ten (10)** days of the date of the Notice to Proceed, in writing. Construction of the project shall be substantially complete within **One Hundred Eighty (180)** consecutive calendar days from the date stipulated on the Notice to Proceed. Final completion shall be attained **Twenty (20)** consecutive calendar days from the date of substantial completion.

Conditions under which Liquidated Damages are Imposed:

Should the Contractor or, in case of his default, the Surety fail to complete the work within the time stipulated in the contract, or within such extra time as may have been granted by the Owner, the Contractor or, in case of his default, the Surety shall pay to the Owner, not as a penalty but as liquidated damages, the amount so due as determined by the following schedule:

<u>Original Contract Amount</u>	<u>Daily Charge Per Calendar Day</u>
\$50,000 and under.....	\$956
Over \$50,000 but less than \$250,000.....	\$964
\$250,000 but less than \$500,000.....	\$1,241
\$500,000 but less than \$2,500,000.....	\$1,665
\$2,500,000 but less than \$5,000,000.....	\$2,712
\$5,000,000 but less than \$10,000,000.....	\$3,447
\$10,000,000 but less than \$15,000,000.....	\$4,866
\$15,000,000 but less than \$20,000,000.....	\$5,818
\$20,000,000 and over.....	\$9,198 (plus 0.00005 of any amount over \$20 million (Round to nearest whole dollar)

INDEMNITY

To the fullest extent permitted by law, the Contractor shall indemnify, defend, and hold harmless the County, its officials, and employees, from and against liability, claims, damages, losses and expenses including attorney’s fees arising out of or resulting from performance of the work, provided that such liability, claims, damages, loss or expense is attributable to bodily injury, sickness, disease or death, or to injury to or destruction of tangible property (other than the work itself) including loss of use resulting therefrom, but only to the extent caused in whole or in part, by negligent acts or omissions of the Contractor, a Subcontractor, or anyone directly or indirectly employed by them or anyone for whose acts they may be liable, regardless of whether or not such liability, claim, damage, loss or expense is caused in part by a party indemnified hereunder.

In claims against any person or entity indemnified under this paragraph by an employee of the Contractor, a Subcontractor, anyone directly or indirectly employed by them or anyone for whose acts they may be liable, the indemnification obligation under this shall not be limited by a limitation on amount or type of damages, compensation or benefits payable by or for the Contractor or a Subcontractor under workers’ compensation acts, disability benefits acts or other employee benefits acts.

CONTRACTOR SAFETY AND HEALTH REQUIREMENTS

The Contractor shall be responsible for supervising all safety precautions, including initiating and maintaining such programs in connection with the performance of the Contract and for adequate maintenance of traffic.

The Contractor shall designate a member of the on-site construction team whose duty shall be the prevention of accidents. Unless notified otherwise in writing by the Contractor to the Owner and the Engineer, this person shall be the Contractor’s Superintendent.

A. OSHA Requirements:

The Contractor warrants that the product, products, or services supplied to St. Johns County shall conform in all respects to the standards set forth in the Occupational Safety and Health Act (OSHA) of 1970 as amended and the failure to comply will be considered a breach of contract. St. Johns County shall be held harmless against any unsafe conditions and contractor employee incidents.

B. Compliance with Occupational Safety and Health Act:

Contractor certifies that all material, equipment, services, etc., furnished in this bid meets all OSHA requirements for the applicable Sectors. Bidder further certifies that, if he is the successful bidder, and the material, equipment, service, etc., delivered or provided is subsequently found to be deficient in any OSHA requirement in effect on date of delivery or service fulfillment date, all costs necessary to bring the material, equipment, service, etc., into compliance with the aforementioned requirements shall be borne by the bidder. All Personal Protective Equipment used by the contractor and their employees shall be ANSI certified and meet OSHA standards.

C. Training and Education:

Contractors will ensure that Contractor employees are trained appropriately for their work tasking. The minimum requirements are found in Federal and State Regulations. Examples of this training are (but not limited to):

- Lockout Tagout
- Fall Protection
- Electrical Safety and the National Electrical Code (NEC)
- Confined Space Entry
- Hot Work
- Specific Chemical Hazards
- Excavations and Trenching
- Heavy Equipment Operation

Special emphasis should be given towards training and compliance with the Construction industry's "Focus Four" established by OSHA as an outreach program to the construction industry and its workers. Training, education, and awareness should be provided in the areas of: 1) Fall Hazards, 2) Caught-In and Between Hazards, 3) Struck-By Hazards, and 4) Electrocution Hazards.

D. Toxic Substances/Federal Hazard Communication "Right To Know and Understand" Regulations:

The Federal "Right to Know and Understand" Regulation (also known as the Hazard Communication / Globally Harmonized System of Classification and Labeling of Chemicals (GHS) implemented by OSHA requires employers to inform their employees of any toxic substances to which they may be exposed in the workplace, and to provide training in safe chemical storage, labeling, handling practices and emergency procedures.

Accordingly, the Contractor(s) performing under this contract shall be required to provide two (2) complete sets of Safety Data Sheets (SDS) to each of the departments utilizing the awarded products. This information should be provided at the time when the initial delivery is made, on a department-by-department basis. If performing work on site, it is preferred that each contractor bring their hazardous communication program and SDS in a binder labeled with the contractor's name and identified as a Hazardous Communication/GHS Program. Upon leaving the jobsite and the removal of all hazardous materials, contractors shall take their information with them. The transport, use, and disposal of toxic substances must be conducted in accordance with DEP/EPA regulations.

Upon request, contractors working at St. Johns County facilities or jobsites will be given access to the written Hazardous Communication Program and informed where to locate SDS.

E. Temporary Traffic Control (TTC)/Maintenance of Traffic (MOT)

The Contractor must comply with the Florida Department of Transportation's (DOT) Temporary Traffic Control (TTC) and the Manual on Uniform Traffic Control Devices (MUTCD) in the planning, development, design, implementation, operation, enforcement and inspection of work zone related transportation management and temporary traffic control on streets and highways within the State Highway System right-of-way. Training in the Advanced, Intermediate, and Flagger categories must be completed by the Contractor for their employees when performing right-of-way work while under contract with St. Johns County. Contractor employees must wear a Class II (daytime), Class III (night/limited visibility) high-visibility safety vest or equivalent high-visibility apparel while performing any work that places them in the right-of-way

TERMINATION

Failure on the part of the Contractor to comply with any portion of the duties and obligations under the Contract Agreement shall be cause for termination. If the Contractor fails to perform any aspect of the responsibilities described herein St. Johns County shall provide written notification of any and all items of non-compliance. The Contractor shall then have five (5) consecutive calendar days to correct any and all items of non-compliance, or take acceptable corrective action, as determined by the County. If the items of non-compliance are not corrected, or acceptable corrective action has not been taken, as determined by the County, within the five (5) consecutive calendar days, the Contract Agreement may be terminated by St. Johns County for cause, upon giving fourteen (14) consecutive calendar days written notice to the Contractor. In the event, the County issues more than one (1) Notice of Non-Compliance or Default during the term of the Contract Agreement, the County may terminate the Contract Agreement, for Cause.

The County may terminate the Contract Agreement at any time, without cause, upon thirty (30) days written notice to the Contractor of intention to do so.

If, at any time, the Contract Agreement with the awarded vendor is terminated by the County, whether for cause or for convenience, the County may, at its sole discretion, negotiate with the second lowest, responsible, responsive bidder, in order to enter into a contract with that vendor to complete the remaining, specified services to prevent a gap in performance of services for the County, if it serves the best interest of the County to do so.

TAXES

Project is subject to Federal Excise and Florida Sales Taxes, which must be included in Bidder's proposal.

INSURANCE

The Contractor shall not commence work under this Contract until he/she has obtained all insurance required under this section and such insurance has been approved by the County. All insurance policies shall be issued by companies authorized to do business under the laws of the State of Florida. The Contractor shall furnish proof of Insurance to the County prior to the commencement of operations. The Certificate(s) shall clearly indicate the Contractor has obtained insurance of the type, amount, and classification as required by contract and that no material change or cancellation of the insurance shall be effective without thirty (30) days prior written notice to the County. Certificates shall specifically include the County as Additional Insured for all lines of coverage except Workers' Compensation and Professional Liability. A copy of the endorsement must accompany the certificate. Compliance with the foregoing requirements shall not relieve the Contractor of its liability and obligations under this Contract.

Certificate Holder Address: St. Johns County, a political subdivision of the State of Florida
500 San Sebastian View
St. Augustine, FL 32084

The Contractor shall maintain during the life of this Contract, Comprehensive General Liability Insurance with minimum limits of \$1,000,000 per occurrence, \$2,000,000 aggregate to protect the Contractor from claims for damages for bodily injury, including wrongful death, as well as from claims of property damages which may arise from any operations under this Contract, whether such operations be by the Contractor or by anyone directly employed by or contracting with the Contractor.

The Contractor shall maintain during the life of this Contract, Comprehensive Automobile Liability Insurance with minimum limits of \$2,000,000 combined single limit for bodily injury and property damage liability to protect the Contractor from claims for damages for bodily injury, including the ownership, use, or maintenance of owned and non-owned automobiles, including rented/hired automobiles whether such operations be by the Contractor or by anyone directly or indirectly employed by a Contractor.

The Contractor shall maintain Umbrella or Excess Liability Insurance covering workers compensation, commercial general liability and business auto liability with minimum limits of liability of \$1,000,000.

The Contractor shall maintain during the life of this Contract, adequate Workers' Compensation Insurance in at least such amounts as are required by the law for all of its employees per Florida Statute 440.02.

In the event of unusual circumstances, the County Administrator, or his designee, may adjust these insurance requirements.

GOVERNING LAWS & REGULATIONS

The Contractor shall be responsible for being familiar and complying with any and all federal, state, and local laws, ordinances, rules and regulations that, in any manner, affect the work required under this contract. The agreement shall be governed by the laws of the State of Florida and St. Johns County both as to interpretation and performance.

For the projects awarded under this contract relating to an Emergency declaration, the Contractor will comply with the strictest provisions of Federal 2 CFR 200, State, and Local procurement Rules, Regulations and/or Ordinances, etc.

It is the intent of the County to ensure that Disadvantaged Business or Small Business Enterprise (DBE/SBE), Minority Business Enterprise (MBE) and Women Business Enterprise (WBE) have equal opportunity to receive and participate in Federal assisted contracts and also uphold the following standards:

- To ensure nondiscrimination in the award and administration of Federal assisted contracts;
- To create a level playing field on which DBEs can compete fairly for Federal assisted contracts;
- To ensure that the DBE Program is narrowly tailored in accordance with applicable law;
- To help remove barriers to the participation of DBEs in Federal assisted contract; and
- To assist the development of firms that can compete successfully in the market place outside the DBE Program.

If the bidder is not a DBE/MBE/WBE firm the contractor entering into an agreement for this project must meet the following criteria:

1. Achieve DBE/MBE/WBE participation by using DBE/MBE/WBE Subcontractors; **OR**
2. If unable to utilize DBE/MBE/WBE certified Subcontractors, must be able to submit documentation detailing the Good Faith Efforts made in utilization of potential DBE/MBE/WBE Subcontractors.

EMPLOYMENT ELIGIBILITY AND MANDATORY USE OF E-VERIFY

As a condition precedent to entering into this Agreement, and in accordance with section 448.095, F.S., Contractor and its subcontractors shall register with and use the E-Verify system to verify the work authorization status of all employees hired on or after January 1, 2021.

- a. Contractor shall require each of its subcontractors to provide Contractor with an affidavit stating that the subcontractor does not employ, contract with, or subcontract with an unauthorized alien. Contractor shall maintain a copy of such affidavit for the duration of this Agreement.
- b. The County, Contractor, or any subcontractor who has a good faith belief that a person or entity with which it is contracting has knowingly violated section 448.09(1), F.S. or these provisions regarding employment eligibility shall terminate the contract with the person or entity.
- c. The County, upon good faith belief that a subcontractor knowingly violated these provisions regarding employment eligibility, but Contractor otherwise complied, shall promptly notify Contractor and Contractor shall immediately terminate the contract with the subcontractor.
- d. The County and Contractor hereby acknowledge and mutually agree that, a contract terminated pursuant to these provisions regarding employment eligibility is not a breach of contract and may not be considered as such. Any contract terminated pursuant to these provisions regarding employment eligibility may be challenged in accordance with section 448.095(2)(d), F.S.
- e. Contractor acknowledges that, in the event that the County terminates this Contract for Contractor's breach of these provisions regarding employment eligibility, then Contractor may not be awarded a public contract for at least one (1) year after such termination. Contractor further acknowledges that Contractor is liable for any additional costs incurred by the County as a result of the County's termination of this Agreement for breach of these provisions regarding employment eligibility.

f. Contractor shall incorporate in all subcontracts made pursuant to this Agreement the provisions contained herein regarding employment eligibility.

PUBLIC RECORDS

A. The cost of reproduction, access to, disclosure, non-disclosure, or exemption of records, data, documents, and/or materials, associated with this Agreement shall be subject to the applicable provisions of the Florida Public Records Law (Chapter 119, Florida Statutes), and other applicable State and Federal provisions. Access to such public records, may not be blocked, thwarted, and/or hindered by placing the public records in the possession of a third party, or an unaffiliated party.

B. In accordance with Florida law, to the extent that Contractor's performance under this Contract constitutes an act on behalf of the County, Contractor shall comply with all requirements of Florida's public records law. Specifically, if Contractor is expressly authorized, and acts on behalf of the County under this Agreement, Contractor shall:

(1) Keep and maintain public records that ordinarily and necessarily would be required by the County in order to perform the Services;

(2) Upon request from the County's custodian of public records, provide the County with a copy of the requested records or allow the records to be inspected or copied within a reasonable time at a cost that does not exceed the cost as provided in Chapter 119, Florida Statutes, or as otherwise provided by law;

(3) Ensure that public records related to this Agreement that are exempt or confidential and exempt from public records disclosure requirements are not disclosed except as authorized by applicable law for the duration of this Agreement and following completion of this Agreement if the Contractor does not transfer the records to the County; and

(4) Upon completion of this Agreement, transfer, at no cost, to the County all public records in possession of the Contractor or keep and maintain public records required by the County to perform the Services.

If the Contractor transfers all public records to the County upon completion of this Agreement, the Contractor shall destroy any duplicate public records that are exempt or confidential and exempt from public records disclosure requirements. If the Contractor keeps and maintains public records upon completion of this Agreement, the Contractor shall meet all applicable requirements for retaining public records. All records stored electronically must be provided to the County, upon request from the County's custodian of public records, in a format that is compatible with the County's information technology systems.

Failure by the Contractor to comply with the requirements of this section shall be grounds for immediate, unilateral termination of this Agreement by the County.

IF THE CONTRACTOR HAS QUESTIONS REGARDING THE APPLICATION OF CHAPTER 119, FLORIDA STATUTES, TO ITS DUTY TO PROVIDE PUBLIC RECORDS RELATING TO THIS AGREEMENT, CONTACT THE CUSTODIAN OF PUBLIC RECORDS AT:

**500 San Sebastian View
St. Augustine, FL 32084
(904) 209-0805
publicrecords@sjcfl.us**

END OF SECTION

**HAZARD MITIGATION GRANT
PROGRAM (HMGP)
REQUIRED CONTRACT CLAUSES**

**HAZARD MITIGATION GRANT PROGRAM (HMGP)
REQUIRED CONTRACT CLAUSES**

1. Equal Employment Opportunity.

- a. The contractor agrees to comply with the requirements of Chapter 760, Florida Statutes, and with Title VI of the Civil Rights Act of 1964 as amended, Title VIII of the Civil Rights Act of 1968 as amended, Section 104(b) and Section 109 of Title I of the Housing and Community Development Act of 1974 as amended, Section 504 of the Rehabilitation Act of 1973, the Americans with Disabilities Act of 1990, the Age Discrimination Act of 1975, Executive Order 11063, and Executive Order 11246 as amended.
- b. If this contract is in excess of \$10,000 and meets the definition of a "federally assisted construction contract" as provided in 41 C.F.R. § 60-1.3, the following shall apply to the contractor's performance under this contract:
 - a. The contractor will not discriminate against any employee or applicant for employment because of race, color, religion, sex, or national origin. The contractor will take affirmative action to ensure that applicants are employed, and that employees are treated during employment without regard to their race, color, religion, sex, or national origin. Such action shall include, but not be limited to the following: Employment, upgrading, demotion, or transfer; recruitment or recruitment advertising; layoff or termination; rates of pay or other forms of compensation; and selection for training, including apprenticeship. The contractor agrees to post in conspicuous places, available to employees and applicants for employment, notices to be provided setting forth the provisions of this nondiscrimination clause.
 - b. The contractor will, in all solicitations or advertisements for employees placed by or on behalf of the contractor, state that all qualified applicants will receive considerations for employment without regard to race, color, religion, sex, or national origin.
 - c. The contractor will not discharge or in any other manner discriminate against any employee or applicant for employment because such employee or applicant has inquired about, discussed, or disclosed the compensation of the employee or applicant or another employee or applicant. This provision shall not apply to instances in which an employee who has access to the compensation information of other employees or applicants as part of such employee's essential job functions discloses the compensation of such other employees or applicants to individuals who do not otherwise have access to such information, unless such disclosure is in response to a formal complaint or charge, in furtherance of an investigation, proceeding, hearing, or action, including an investigation conducted by the employer, or is consistent with the contractor's legal duty to furnish information.
 - d. The contractor will send to each labor union or representative of workers with which he has a collective bargaining agreement or other contract or understanding, a notice to be provided advising the said labor union or workers' representatives of the contractor's commitments under this section, and shall post copies of the notice in conspicuous places available to employees and applicants for employment.
 - e. The contractor will comply with all provisions of Executive Order 11246 of September 24, 1965, and of the rules, regulations, and relevant orders of the Secretary of Labor.

- f. The contractor will furnish all information and reports required by Executive Order 11246 of September 24, 1965, and by rules, regulations, and orders of the Secretary of Labor, or pursuant thereto, and will permit access to his books, records, and accounts by the administering agency and the Secretary of Labor for purposes of investigation to ascertain compliance with such rules, regulations, and orders.
- g. In the event of the contractor's noncompliance with the nondiscrimination clauses of this contract or with any of the said rules, regulations, or orders, this contract may be canceled, terminated, or suspended in whole or in part and the contractor may be declared ineligible for further Government contracts or federally assisted construction contracts in accordance with procedures authorized in Executive Order 11246 of September 24, 1965, and such other sanctions as may be imposed and remedies invoked as provided in Executive Order 11246 of September 24, 1965, or by rule, regulation, or order of the Secretary of Labor, or as otherwise provided by law.
- h. The contractor will include the portion of the sentence immediately preceding paragraph (a) and the provisions of paragraphs (a) through (h) in every subcontract or purchase order unless exempted by rules, regulations, or orders of the Secretary of Labor issued pursuant to section 204 of Executive Order 11246 of September 24, 1965, so that such provisions will be binding upon each subcontractor or vendor. The contractor will take such action with respect to any subcontract or purchase order as the administering agency may direct as a means of enforcing such provisions, including sanctions for noncompliance: Provided, however, that in the event a contractor becomes involved in, or is threatened with, litigation with a subcontractor or vendor as a result of such direction by the administering agency the contractor may request the United States to enter into such litigation to protect the interests of the United States.

For the purposes of this section, "federally assisted construction contract" means any agreement or modification thereof between any applicant and a person for construction work which is paid for in whole or in part with funds obtained from the Government or borrowed on the credit of the Government pursuant to any Federal program involving a grant, contract, loan, insurance, or guarantee, or undertaken pursuant to any Federal program involving such grant, contract, loan, insurance, or guarantee, or any application or modification thereof approved by the Government for a grant, contract, loan, insurance, or guarantee under which the applicant itself participates in the construction work.

For the purposes of this section, "construction work" means the construction, rehabilitation, alteration, conversion, extension, demolition or repair of buildings, highways, or other changes or improvements to real property, including facilities providing utility services. The term also includes the supervision, inspection, and other onsite functions incidental to the actual construction.

2. **Contract Work Hours and Safety Standards Act.**

- a. This section applies to all contracts in excess of \$100,000 that involve the employment of mechanics or laborers as provided in 40 U.S.C. § 3701.
- b. As provided in 40 U.S.C. § 3702, and as supplemented by Department of Labor regulations (29 C.F.R. Part 5), the contractor shall compute the wages of every mechanic and laborer on the basis of a standard work week of 40 hours. Work in excess of the standard work week is permissible provided that the worker is compensated at a rate of not less than one and a half times the basic rate of pay for all hours worked in excess of 40 hours in the work week.
- c. The requirements of 40 U.S.C. § 3704, as supplemented by 29 C.F.R. Part 5, shall apply to construction work and provide that no laborer or mechanic must be required to work in surroundings or under working conditions which are unsanitary, hazardous or dangerous. These requirements do not apply to the purchases of supplies or materials or articles ordinarily available on the open market, or contracts for transportation or transmission of intelligence.

- d. No contractor or subcontractor contracting for any part of the contract work which may require or involve the employment of laborers or mechanics shall require or permit any such laborer or mechanic in any workweek in which he or she is employed on such work to work in excess of forty hours in such workweek unless such laborer or mechanic receives compensation at a rate not less than one and one-half times the basic rate of pay for all hours worked in excess of forty hours in such workweek.
- e. In the event of any violation of the clause set forth in paragraph (d) of this section the contractor and any subcontractor responsible therefor shall be liable for the unpaid wages. In addition, such contractor and subcontractor shall be liable to the United States (in the case of work done under contract for the District of Columbia or a territory, to such District or to such territory), for liquidated damages. Such liquidated damages shall be computed with respect to each individual laborer or mechanic, including watchmen and guards, employed in violation of the clause set forth in paragraph (d) of this section, in the sum of \$10 for each calendar day on which such individual was required or permitted to work in excess of the standard workweek of forty hours without payment of the overtime wages required by the clause set forth in paragraph (d) of this section.
- f. The County shall upon its own action or upon written request of an authorized representative of the Department of Labor withhold or cause to be withheld, from any moneys payable on account of work performed by the contractor or subcontractor under any such contract or any other Federal contract with the same prime contractor, or any other federally-assisted contract subject to the Contract Work Hours and Safety Standards Act, which is held by the same prime contractor, such sums as may be determined to be necessary to satisfy any liabilities of such contractor or subcontractor for unpaid wages and liquidated damages as provided in the clause set forth in paragraph (e) of this section.
- g. The contractor or subcontractor shall insert in any subcontracts the clauses set forth in paragraph (c) through (f) of this section and also a clause requiring the subcontractors to include these clauses in any lower tier subcontracts. The prime contractor shall be responsible for compliance by any subcontractor or lower tier subcontractor with the clauses set forth in paragraphs (c) through (f) of this section.

3. Compliance With Clean Air Act.

- a. This provision applies to any contract or subgrant in excess of \$150,000 that is funded entirely or in part with federal funds.
- b. The contractor agrees to comply with all applicable standards, orders or regulations issued pursuant to the Clean Air Act, as amended, 42 U.S.C. § 7401 et seq.
- c. The contractor agrees to report each violation to the County and understands and agrees that the County will, in turn, report each violation as required to assure notification to the state of Florida, Federal Emergency Management Agency, and the appropriate Environmental Protection Agency Regional Office.
- d. The contractor agrees to include these requirements in each subcontract exceeding \$100,000 financed in whole or in part with Federal assistance provided through Hazard Mitigation Grant Program funds.

4. Compliance with Federal Water Pollution Control Act.

- a. This provision applies to any contract or subgrant in excess of \$150,000 that is funded entirely or in part with federal funds.
- b. The contractor agrees to comply with all applicable standards, orders or regulations issued pursuant to the Federal Water Pollution Control Act, as amended, 33 U.S.C. 1251 et seq.
- c. The contractor agrees to report each violation to the County and understands and agrees that the County will, in turn, report each violation as required to assure notification to the state of Florida, Federal Emergency Management Agency, and the appropriate Environmental Protection Agency Regional Office.
- d. The contractor agrees to include these requirements in each subcontract exceeding \$100,000 financed in whole or in part with Federal assistance provided through Hazard Mitigation Grant Program funds.

5. Debarment and Suspension.

- a. This contract is a covered transaction for purposes of 2 C.F.R. Part 180 and 2 C.F.R. Part 3000. As such the contractor is required to verify that none of the contractor, its principals (defined at 2 C.F.R. § 180.995), or its affiliates (defined at 2 C.F.R. § 180.905) are excluded (defined at 2 C.F.R. § 180.940) or disqualified (defined at 2 C.F.R. § 180.935).
- b. The contractor must comply with 2 C.F.R. Part 180, Subpart C and 2 C.F.R. Part 3000, Subpart C and must include a requirement to comply with these regulations in any lower tier covered transaction it enters into. This requirement includes, but is not limited to verifying that any entity with whom the contractor intends to do business is not excluded or disqualified by:
 - i. Checking the Excluded Parties List System for Award Management (SAM), available at <https://www.sam.gov/portal/public/SAM/>;
 - ii. Collecting a certification from that entity; or
 - iii. Adding a clause or condition to the covered transaction with that entity.
- c. This certification is a material representation of fact relied upon by the County. If it is later determined that the contractor did not comply with 2 C.F.R. Part 180, Subpart C and 2 C.F.R. Part 3000, Subpart C, in addition to remedies available to the state of Florida and the County, the Federal Government may pursue available remedies, including but not limited to suspension and/or debarment.
- d. The bidder or proposer agrees to comply with the requirements of 2 C.F.R. Part 180, Subpart C and 2 C.F.R. Part 3000, Subpart C while this offer is valid and throughout the period of any contract that may arise from this offer. The bidder or proposer further agrees to include a provision requiring such compliance in its lower tier covered transactions.

6. Byrd Anti-Lobbying Amendment

Contractors who apply or bid for an award of \$100,000 or more shall file the required certification. Each tier certifies to the tier above that it will not and has not used Federal appropriated funds to pay any person or organization for influencing or attempting to influence an officer or employee of any agency, a member of Congress, officer or employee of Congress, or an employee of a member of Congress in connection with obtaining any Federal contract, grant, or any other award covered by 31 U.S.C. § 1352. Each tier shall also disclose any lobbying with non-Federal funds that takes place in connection with obtaining any Federal award. Such disclosures are forwarded from tier to tier up to the recipient.

APPENDIX A, 44 C.F.R. PART 18: CERTIFICATION REGARDING LOBBYING

Certification for Contracts, Grants, Loans, and Cooperative Agreements (To be submitted with each bid or offer exceeding \$100,000)

The undersigned [Contractor] certifies, to the best of his or her knowledge, that:

- 1. No Federal appropriated funds have been paid or will be paid, by or on behalf of the undersigned, to any person for influencing or attempting to influence an officer or employee of an agency, a Member of Congress, an officer or employee of Congress, or an employee of a Member of Congress in connection with the awarding of any Federal contract, the making of any Federal grant, the making of any Federal loan, the entering into of any cooperative agreement, and the extension, continuation, renewal, amendment, or modification of any Federal contract, grant, loan, or cooperative agreement.
- 2. If any funds other than Federal appropriated funds have been paid or will be paid to any person for influencing or attempting to influence an officer or employee of any agency, a Member of Congress, an officer or employee of Congress, or an employee of a Member of Congress in connection with this Federal contract, grant, loan, or cooperative agreement, the undersigned shall

complete and submit Standard Form- LLL, "Disclosure Form to Report Lobbying," in accordance with its instructions.

3. The undersigned shall require that the language of this certification be included in the award documents for all subawards at all tiers (including subcontracts, subgrants, and contracts under grants, loans, and cooperative agreements) and that all subrecipients shall certify and disclose accordingly.

This certification is a material representation of fact upon which reliance was placed when this transaction was made or entered into. Submission of this certification is a prerequisite for making or entering into this transaction imposed by 31 U.S.C. § 1352 (as amended by the Lobbying Disclosure Act of 1995). Any person who fails to file the required certification shall be subject to a civil penalty of not less than \$10,000 and not more than \$100,000 for each such failure.

The Contractor certifies or affirms the truthfulness and accuracy of each statement of its certification and disclosure, if any. In addition, the Contractor understands and agrees that the provisions of 31 U.S.C. § 3801 et seq., apply to this certification and disclosure, if any.

Signature of Contractor's Authorized Official

Name and Title of Contractor's Authorized Official

Date

7. Procurement of Recovered Materials.

- a. In the performance of this contract, the contractor shall comply with Section 6002 of the Solid Waste Disposal Act, as amended by the Resource Recovery Act. The contractor shall make maximum use of products containing recovered materials that are EPA- designated items, as set forth in 40 C.F.R. Part 247, Subpart B, unless the product cannot be acquired—
 - i. Competitively within a timeframe providing for compliance with the contract performance schedule;
 - ii. Meeting contract performance requirements; or
 - iii. At a reasonable price.
- b. The requirements of this section apply to the purchase or acquisition of any procurement item where the purchase price of the item exceeds \$10,000 or where the quantity of such item or of any functionally equivalent item purchased or acquired in the course of the previous fiscal year is \$10,000 or more.

8. Access to Records.

- a. The contractor agrees to provide the County, the FEMA Administrator, the Comptroller General of the United States, or any of their authorized representatives access to any books, documents, papers, and records of the contractor which are directly pertinent to this contract for the purpose of making audits, examinations, excerpts, and transcriptions.
- b. The contractor agrees to permit any of the foregoing parties to reproduce by any means whatsoever or to copy excerpts and transcriptions as reasonably needed.
- c. The contractor agrees to provide the FEMA Administrator or his authorized representatives access to construction or other work sites pertaining to the work being completed under the contract.

9. DHS Seal, Logo, and Flags.

The contractor shall not use the Department of Homeland Security (DHS) seal(s), logos, crests, or reproductions of

flags or likenesses of DHS agency officials without specific FEMA pre-approval.

10. Compliance with Federal Law, Regulations, and Executive Orders.

This is an acknowledgement that this contract is funded entirely or in part by Hazard Mitigation Grant Program funds. The contractor will comply with all applicable federal law, regulations, executive orders, and FEMA policies, procedures, and directives, including, but not limited to:

- a. The Robert T. Stafford Disaster Relief and Emergency Management Act;
- b. 44 CFR Parts 7, 9, 10, 13, 14, 17, 18, 25, 206, 220, and 221, and any other applicable FEMA policy memoranda and guidance documents;
- c. State of Florida Administrative Plan for the Hazard Mitigation Grant Program;
- d. Hazard Mitigation Assistance Guidance – February 27, 2015 Update; and
- e. All applicable laws and regulations delineated in Attachment C of the Federally-Funded Subaward and Grant Agreement between St. Johns County and the Florida Division of Emergency Management (Agreement No. H0025)

11. No Obligation by Federal Government.

The Federal Government is not a party to this contract and is not subject to any obligations or liabilities to the non-Federal entity, contractor, or any other party pertaining to any matter resulting from the contract.

12. Fraud and False or Fraudulent or Related Acts.

The contractor acknowledges that 31 U.S.C. Chap. 38 (Administrative Remedies for False Claims and Statements) applies to the contractor's actions pertaining to this contract.

END OF SECTION

BID NO: 21-101

**OFFICIAL COUNTY BID FORM
WITH ATTACHMENTS**

BID NO: 21-101

**OFFICIAL COUNTY BID FORM
ST. JOHNS COUNTY, FLORIDA**

PROJECT: SIGNALIZATION REPLACEMENT AT INTERSECTION OF US 1 / LEWIS POINT ROAD / ST. AUGUSTINE SOUTH DRIVE – HMGP 4283-011-R

TO: THE BOARD OF COUNTY COMMISSIONERS OF ST. JOHNS COUNTY, FLORIDA

DATE SUBMITTED: _____

BID PROPOSAL OF

Full Legal Company Name

Mailing Address

Telephone Number

Fax Number

Bidders: Having become familiar with requirements of the project, and having carefully examined the Bidding Documents and Specifications entitled for Bid No: 21-101; Signalization Replacement at Intersection of US 1 / Lewis Point Road / St. Augustine South Drive – HMGP 4283-011-R in St. Johns County, Florida, the undersigned proposes to furnish all materials, labor and equipment, supervision and all other requirements necessary to comply with the Contract Documents to submit the following Bid Proposal summarized as follows:

TOTAL LUMP SUM BID PRICE: (As per plans and specifications) ---

\$ _____
Total Lump Sum Bid Price (Numerical)

/100 Dollars

Total Lump Sum Bid Price (Amount written or typed in words)

Bidder shall insert the Total Lump Sum Bid Price in numerals and in words. Any discrepancy between the two submitted amounts shall be determined by the amount written in words.

The Total Lump Sum Bid Price offered in this Bid Proposal must remain firm for a period of ninety (90) days from the Bid opening date.

BID NO: 21-101

During the preparation of the Bid, the following addenda, if any, were received:

No.: _____ Date Received:

No.: _____ Date Received:

No.: _____ Date Received:

We, the undersigned, hereby declare that no person or persons, firm or corporation, other than the undersigned are interested, in this proposal, as principals, and that this proposal is made without collusion with any person, firm or corporation, and we have carefully and to our satisfaction examined the Bid Documents and Project Specifications.

We have made a full examination of the location of the proposed work and the sources of supply of materials, and we hereby agree to furnish all necessary labor, equipment and materials, fully understanding that any quantities shown therewith are approximate only, and that we will fully complete all requirements therein as prepared by the Owner, within the same time limit specified in the Bid Documents as indicated above.

If the Undersigned is notified of the acceptance of this Bid Proposal by the Board within ninety (90) calendar days for the time set for the opening of Bids, the Undersigned further agrees, to execute a contract for the above work within ten (10) days after notice that his Bid has been accepted for the above stated compensation in the form of a Contract presented by the Owner.

The Undersigned further agrees that security in the form of a Bid Bond, certified or cashier's check in the amount of not less than five percent (5%) of Total Lump Sum Bid Price, payable to the Owner, accompanies this Bid; that the amount is not to be construed as a penalty, but as liquidated damages which said Owner will sustain by failure of the Undersigned to execute and deliver the Contract and Bond within ten (10) days of the written notification of the Award of the Contract to him; thereupon, the security shall become the property of the Owner, but if this Bid is not accepted within ninety (90) days of the time set for the submission of Bids, or if the Undersigned delivers the executed Contract upon receipt, the Security shall be returned to the Bidder within seven (7) working days.

BID NO: 21-101

CORPORATE/COMPANY

Full Legal Company Name: _____ (Seal)

By: _____
Signature of Authorized Representative (Name & Title typed or printed)

By: _____
Signature of Authorized Representative (Name & Title typed or printed)

Address: _____

Telephone No.: (____) _____ Fax No.: (____) _____

Email Address for Authorized Company Representative: _____

Federal I.D. Tax Number: _____ DUNS #: _____
(If applicable)

INDIVIDUAL

Name: _____
(Signature) (Name typed or printed) (Title)

Address: _____

Telephone No.: (____) _____ Fax No.: _____

Email Address: _____

Federal I.D. Tax Number: _____

- Submittal Requirements:
- Official County Unit Price Bid Form
 - Attachment "A" – St Johns County Board of County Commissioners Affidavit
 - Attachment "B" – Certificate as to Corporate Principal
 - Attachment "C" – License / Certification List
 - Attachment "D" – List of Proposed Sub-Contractors/Suppliers
 - Attachment "E" – Conflict of Interest Disclosure Form
 - Attachment "F" – Drug-Free Workplace Form
 - Attachment "G" – Proof of Insurance
 - Attachment "H" – Experience of Bidder Form
 - Attachment "I" – Claims, Liens, Litigation History
 - Attachment "J" – E-Verify Affidavit
 - Attachment "K" – Certificate of Compliance with Florid Trench Safety Act
 - Attachment "L" – Sworn Statement on Public Entity Crimes
 - Attachment "M" – Certification Regarding Debarment, Suspension, Ineligibility & Voluntary Exclusion
 - Attachment "N" – Certification for Disclosure of Lobbying Activities
 - Attachment "O" – Unit Prices for Adjustments/Schedule of Values
 - Bid Bond Form
 - Fully Acknowledged Addenda Applicable to this bid

Official County Bid Form, Attachments, and Bid Bond must be completed, along with a fully acknowledged copy of each Addendum applicable to this Bid and submitted with each copy of the Bid Proposal.

BID NO: 21-101

ATTACHMENT "A"

ST. JOHNS COUNTY, BOARD OF COUNTY COMMISSIONERS AFFIDAVIT

TO: ST. JOHNS COUNTY, BOARD OF COUNTY COMMISSIONERS,
ST. JOHNS COUNTY, ST. AUGUSTINE, FLORIDA.

At the time the proposal is submitted, the Bidder shall attach to his Bid a sworn statement.

This sworn statement shall be an affidavit in the following form, executed by an officer of the firm, association, or corporation submitting the proposal, and shall be sworn to before a person who is authorized by law to administer oaths.

STATE OF FLORIDA, COUNTY OF ST. JOHNS

Before me, the Undersigned authority, personally appeared _____ who being duly sworn, deposes and says he is _____ (Title) of the firm of _____ Bidder submitting the attached proposal for the services covered by the bid documents for Bid No: 21-101; Signalization Replacement at Intersection of US 1 / Lewis Point Road / St. Augustine South Drive – HMGP 4283-011-R, in St. Johns County, Florida.

The affiant further states that no more than one proposal for the above-referenced project will be submitted from the individual, his firm or corporation under the same or different name, and that such Bidder has no financial interest in the firm of another bidder for the same work. That neither he, his firm, association nor corporation has either directly or indirectly entered into any agreement, participated in any collusion, nor otherwise taken any action in restraint of free competitive bidding in connection with this firm's Bid on the above-described project. Furthermore, neither the firm nor any of its officers are barred from participating in public contract lettings in the State of Florida or any other state.

(Bidder)

Sworn and subscribed to me this _____ day
of _____, 20____.

By: _____

(Title)

Notary Public:

Signature

Printed

My commission Expires: _____

BIDDER ON ALL COUNTY PROJECTS MUST EXECUTE AND ATTACH THIS AFFADAVIT TO EACH BID.

BID NO: 21-101

ATTACHMENT "B"

CERTIFICATES AS TO CORPORATE PRINCIPAL

I, _____, certify that I am the Secretary of the Corporation named as Principal in the attached bond; that _____ who signed the said bond on behalf of the Principal, was then _____ of said Corporation; that I know his signature, and his signature hereto is genuine; and that said bond was duly signed, sealed, and attested for and in behalf of said Corporation by authority of its governing body.

Secretary

Corporate Seal

(STATE OF FLORIDA
COUNTY OF ST. JOHNS)

Before me, a Notary Public duly commissioned, qualified and acting, personally appeared to me well known, who being by me first duly sworn upon oath, says that he is the Attorney-In-Fact, for the and that he has been authorized by _____ to execute the foregoing bond on behalf of the surety named therein in favor of St. Johns County, Florida.

Subscribed and sworn to me this _____ day of _____, 20 __, A.D.

NOTARY PUBLIC
State of Florida-at-large

My Commission Expires:

(Attach Power of Attorney to original Bid Bond and Financial Statement of Surety Company)

ATTACHMENT "E"

St. Johns County Board of County Commissioners

CONFLICT OF INTEREST DISCLOSURE FORM

Project (RFQ, RFP, BID) Number/Description: Bid No 21-101; Signalization Replacement at Intersection of US 1 / Lewis Point Road / St. Augustine South Drive – HMGP 4283-011-R

The term "conflict of interest" refers to situations in which financial or other considerations may adversely affect, or have the appearance of adversely affecting a consultant's/contractor's professional judgment in completing work for the benefit of St. Johns County ("County"). The bias such conflicts could conceivably impart may inappropriately affect the goals, processes, methods of analysis or outcomes desired by the County.

Consultants/Contractors are expected to safeguard their ability to make objective, fair, and impartial decisions when performing work for the benefit of the County. Consultants/Contractors, therefore must there avoid situations in which financial or other considerations may adversely affect, or have the appearance of adversely affecting the consultant's/contractor's professional judgement when completing work for the benefit of the County.

The mere appearance of a conflict may be as serious and potentially damaging as an actual distortion of goals, processes, and methods of analysis or outcomes. Reports of conflicts based upon appearances can undermine public trust in ways that may not be adequately restored even when the mitigating facts of a situation are brought to light. Apparent conflicts, therefore, should be disclosed and evaluated with the same vigor as actual conflicts.

It is expressly understood that failure to disclose conflicts of interest as described herein may result in immediate disqualification from evaluation or immediate termination from work for the County.

Please check the appropriate statement:

I hereby attest that the undersigned Respondent has no actual or potential conflict of interest due to any other clients, contracts, or property interests for completing work on the above referenced project.

The undersigned Respondent, by attachment to this form, submits information which may be a potential conflict of interest due to other clients, contracts or property interests for completing work on the above referenced project.

Legal Name of Respondent: _____

Authorized Representative(s) : _____
Signature Print Name/Title

Signature Print Name/Title

BID NO: 21-101

St. Johns County Board of County Commissioners

ATTACHMENT "F"

DRUG-FREE WORKPLACE FORM

The undersigned firm, in accordance with Florida Statute 287.087 hereby certifies that

_____ does:

Name of Firm

1. Publish a statement notifying employees that the unlawful manufacture, distribution, dispensing, possession or use of a controlled substance is prohibited in the workplace and specifying the actions that will be taken against employees for violations of such prohibition.
2. Inform employees about the danger of drug abuse in the workplace, the business' policy of maintaining a drug-free workplace, any available drug counseling, rehabilitation, employee assistance programs and the penalties that may be imposed upon employees for drug abuse violations.
3. Give each employee engaged in providing the contractual services that are described in St. Johns County's request for proposals a copy of the statement specified in paragraph 1.
4. In the statement specified in paragraph 1, notify the employees that, as a condition of working on the contractual services described in paragraph 3, the employee will abide by the terms of the statement and will notify the employer of any conviction of, or plea of guilty or nolo contendere to, any violation of Florida Statute 893, as amended, or of any controlled substance law of the United States or any state, for a violation occurring in the workplace no later than five (5) days after such conviction or plea.
5. Impose a sanction on, or require the satisfactory participation in a drug abuse assistance or rehabilitation program if such is available in the employee's community by, any employee who is so convicted.
6. Consistent with applicable provisions with State or Federal law, rule, or regulation, make a good faith effort to continue to maintain a drug-free workplace through implementation of paragraphs 1 through 5.

As the person authorized to sign this statement, I certify that this firm complies fully with the above requirements.

Signature

Date

BID NO: 21-101

ATTACHMENT "G"

PROOF OF INSURANCE

Respondents shall provide certificates of insurance as part of their submittal package. Certificates of insurance shall meet or exceed the requirements as described under Insurance.

Failure to provide proof of current insurance coverage or ability to obtain the required coverages may result in being deemed non-responsive and removed from further consideration.

(Attach or insert copy of "Certificate of Insurance" here)

BID NO: 21-101

ATTACHMENT "H"

EXPERIENCE OF BIDDER

Bidder acknowledges that he is fully licensed to perform work in the STATE OF FLORIDA.

The Bidder shall provide the following information regarding experience within the **past ten (10) years** of this solicitation. Bidder must demonstrate the successful completion of **three (3) projects** equal to or greater than the scope and dollar value of that being proposed.

Any material misrepresentation, as determined by the County, shall result in disqualification.

By: _____
Bidder

Authorized Signature

_____ Date

DATE OF CONTRACT	CLIENT'S NAME, ADDRESS, PHONE AND EMAIL	CONTRACT AMOUNT	PROJECT AND LOCATION

ATTACHMENT "I"

CLAIMS, LIENS, LITIGATION HISTORY
(Complete and Submit)

1. Within the past 7 years, has your organization filed suit or a formal claim against a project owner (as a prime or subcontractor) or been sued by or had a formal claim filed by an owner, subcontractor or supplier resulting from a construction dispute? Yes _____ No _____ If yes, please attach additional sheet(s) to include:

Description of every action Captions of the Litigation or Arbitration

Amount at issue: _____ Name (s) of the attorneys representing all parties:

Amount actually recovered, if any: _____

Name(s) of the project owner(s)/manager(s) to include address and phone number:

2. List all pending litigation and or arbitration.
3. List and explain all litigation and arbitration within the past seven (7) years - pending, resolved, dismissed, etc.
4. Within the past 7 years, please list all Liens, including Federal, State and Local, which have been filed against your Company. List in detail the type of Lien, date, amount and current status of each Lien.
5. Have you ever abandoned a job, been terminated or had a performance/surety bond called to complete a job?
Yes _____ No _____ If yes, please explain in detail:
6. For all claims filed against your company within the past five-(5) years, have all been resolved satisfactorily with final judgment in favor of your company within 90 days of the date the judgment became final? Yes ____ No ____
If no, please explain why?
7. List the status of all pending claims currently filed against your company:

Liquidated Damages

1. Has a project owner ever withheld retainage, issued liquidated damages or made a claim against any Performance and Payment Bonds? Yes _____ No _____ If yes, please explain in detail:

(Use additional or supplemental pages as needed)

BID NO: 21-101

ATTACHMENT "J"
E-VERIFY AFFIDAVIT

STATE OF _____
COUNTY OF _____

I, _____ (hereinafter "Affiant"), being duly authorized by and on behalf of _____ (hereinafter "Consultant/Contractor") hereby swears or affirms as follows:

1. Consultant/Contractor understands that E-Verify, authorized by Illegal Immigration Reform and Immigrant Responsibility Act of 1996 (IIRIRA), is a web-based system provided by the United States Department of Homeland Security, through which employers electronically confirm the employment eligibility of their employees.
2. For the duration of Contract No. _____ (hereinafter "Agreement"), in accordance with section 448.095, F.S., Consultant/Contractor shall utilize the U.S. Department of Homeland Security's E-Verify system to verify the employment eligibility of all new employees hired by the Consultant/Contractor and shall expressly require any subcontractors performing work or providing services pursuant to the Agreement to likewise utilize the U.S. Department of Homeland Security's E-Verify system to verify the employment eligibility of all new employees hired by the subcontractor.
3. Consultant/Contractor shall comply with all applicable provisions of section 448.095, F.S., and will incorporate in all subcontracts the obligation to comply with section 448.095, F.S.
4. Consultant/Contractor understands and agrees that its failure to comply with all applicable provisions of section 448.095, F.S. or its failure to ensure that all employees and subcontractors performing work under the Agreement are legally authorized to work in the United States and the State of Florida constitute a breach of the Agreement for which St. Johns County may immediately terminate the Agreement without notice and without penalty. The Consultant/Contractor further understands and agrees that in the event of such termination, Consultant/Contractor shall be liable to the St. Johns County for any costs incurred by the St. Johns County resulting from Consultant/Contractor's breach.

DATED this _____ day of _____, 20____.

Signature of Affiant

Printed Name of Affiant

Printed Title of Affiant

Full Legal Name of Consultant/Contractor

Sworn to (or affirmed) and subscribed before me by means of physical presence or online notarization, this ____ day of _____, 20____, by _____, who is personally known to me or has produced _____ as identification.

Notary Public
My Commission Expires: _____

BID NO: 21-101

ATTACHMENT "K"

CERTIFICATE OF COMPLIANCE WITH FLORIDA TRENCH SAFETY ACT

Bidder acknowledges that he is solely responsible for complying with the Florida Trench Safety Act (ACT) and Occupational Safety and Health Administrations excavation safety standard 29 CFR 1926.650 (Subpart P as amended) and the St. Johns County Trenching and Excavation Safety Program. If there is a conflict between the ACT and the St. Johns County Trenching and Excavation Safety Program, the more stringent requirement would apply. Bidder further acknowledges that included in the various items of the proposal and in the Total Bid Price are costs for complying with the Florida Trench Safety Act (90-96, Laws of Florida) effective October 1, 1990 and the Occupational Safety and Health Administrations excavation safety standard.

By: _____

Bidder

Date

Authorized Signature

BID NO: 21-101

ATTACHMENT "L"

SWORN STATEMENT UNDER SECTION 287.133(3)(A), FLORIDA STATUTES, ON PUBLIC ENTITY CRIMES

(To be signed in the presence of notary public or other officer authorized to administer oaths.)

Before me, the undersigned Authority, personally appeared affiant _____, who, being by me first duly sworn, made the following statement:

1. The business address of _____ (name of Offeror or business) is _____.
2. My relationship to _____ (name of Offeror or business) is _____ (relationship such as sole proprietor, partner, president, vice president).
3. I understand that a public entity crime as defined in Section 287.133 of the Florida Statutes includes a violation of any state or federal law by a person with respect to and directly related to the transaction of business with any public entity in Florida or with an agency or political subdivision of any other state or with the United States, including, but not limited to, any proposal or contract for goods or services to be provided to any public entity or such an agency or political subdivision and involving antitrust, fraud, theft, bribery, collusion, racketeering, conspiracy or material misrepresentation.
4. I understand that "convicted" or "conviction" is defined by the Florida Statutes to mean a finding of guilt or a conviction of a public entity crime, with or without an adjudication of guilt, in any federal or state trial court of record relating to charges brought by indictment or information after July 1, 1989, as a result of a jury verdict, non-jury trial, or entry of a plea of guilt or nolo contendere.
5. I understand that "affiliate" is defined by the Florida Statutes to mean (1) a predecessor or successor of a person or a corporation convicted of a public entity crime, or (2) an entity under the control of any natural person who is active in the management of the entity and who has been convicted of a public entity crime, or (3) those officers, directors, executives, partners, shareholders, employees, members, and agents who are active in the management of an affiliate, or (4) a person or corporation who knowingly entered into a joint venture with a person who has been convicted of a public entity crime in Florida during the preceding 36 months.
6. Neither the Offeror or contractor, nor any officer, director, executive, partner, shareholder, employee, member or agent who is active in the management of the Offeror or contractor, nor any affiliate of the Offeror or contractor has been convicted of a public entity crime subsequent to July 1, 1989. (Draw a line through paragraph 6 if paragraph 7 below applies.)
7. There has been a conviction of a public entity crime by the Offeror or contractor, or an officer, director, executive, partner, shareholder, employee, member or agent of the Offeror or contractor who is active in the management of the Offeror or contractor or an affiliate of the Offeror or contractor. A determination has been made pursuant to Section 287.133(3) by order of the Division of Administrative Hearings that it is not in the public interest for the name of the convicted person or affiliate to appear on the convicted vendor list. The name of the convicted person or affiliate is _____. A copy of the order of the Division of Administrative Hearings is attached to this statement. **(Draw a line through paragraph 7 if paragraph 6 above applies.)**

 Name of Business

By: _____
 Printed Name: _____
 Title: _____

STATE OF _____
 COUNTY OF _____

Sworn to (or affirmed) and subscribed before me this ____ day of _____, 20 __, by _____, as _____ and who:

[Notary: Please select one]

- is personally known to me; or
- has produced _____ as identification.

 Notary Public, State of _____
 Printed, typed or stamped name, commission and expiration:

ATTACHMENT "M"

(Complete and Submit Attachment "M" for Prime Bidder and each proposed Sub-Contractor)

**Certification Regarding
Debarment, Suspension,
Ineligibility and Voluntary Exclusion**

Subcontractor Covered Transactions

- (1) The prospective subcontractor, _____ of the Sub-Recipient certifies, by submission of this document, that neither it nor its principals is presently debarred, suspended, proposed for debarment, declared ineligible or voluntarily excluded from participation in this transaction by any Federal department or agency.
- (2) Where the Sub-Recipient's subcontractor is unable to certify to the above statement, the prospective contractor shall attach an explanation to this form.

SUBCONTRACTOR:

By _____
Signature

St. Johns County BOCC
Sub-Recipient's Name

Name and Title

H0013
Division Contract Number

Street Address

#4283-011-R
HMGP Project Number

City, State, Zip

Date

BID NO: 21-101

ATTACHMENT "N"

CERTIFICATION FOR DISCLOSURE OF LOBBYING ACTIVITIES

The prospective participant certifies, by signing this certification, that to the best of his or her knowledge and belief:

- (1) No federal appropriated funds have been paid or will be paid, by or on behalf of the undersigned, to any person for influencing or attempting to influence an officer or employee of any federal agency, a Member of Congress, an officer or employee of Congress, or an employee of a Member of Congress in connection with the awarding of any federal contract, the making of any federal grant, the making of any federal loan, the entering into of any cooperative agreement, and the extension, continuation, renewal, amendment, or modification of any federal contract, grant, loan, or cooperative agreement.
- (2) If any funds other than federal appropriated funds have been paid or will be paid to any person for influencing or attempting to influence an officer or employee of any federal agency, a Member of Congress, an officer or employee of Congress, or an employee of a Member of Congress in connection with this federal contract, grant, loan, or cooperative agreement, the undersigned shall complete and submit Standard Form-LLL, "Disclosure of Lobbying Activities", in accordance with its instructions. (Standard Form-LLL can be obtained from the Florida Department of Transportation's Professional Services Administrator or Procurement Office.)

This certification is a material representation of fact upon which reliance was placed when this transaction was made or entered into. Submission of this certification is a prerequisite for making or entering into this transaction imposed by Section 1352, Title 31, U.S. Code. Any person who fails to file the required certification shall be subject to a civil penalty of not less than \$10,000 and not more than \$100,000 for each such failure.

The prospective participant also agrees by submitting his or her proposal that he or she shall require that the language of this certification be included in all lower tier subcontracts, which exceed \$100,000 and that all such sub recipients shall certify and disclose accordingly.

Legal Name of Contractor: _____

By: _____ Date: _____

Authorized Signature: _____

Title: _____

ATTACHMENT "O"

UNIT PRICES FOR ADJUSTMENT/SCHEDULE OF VALUES

The following unit prices, if approved by the Owner, will be used for adjusting the Contract Price for changes in the work (additions or deletions) in accordance with the provisions of an approved change order and any other modifications of the Contract. Unit prices shall include all labor, materials, equipment, transportation, supervision, insurance cost, bond cost, overhead and profit representing an in-place price for each item. Scope or size of each item not otherwise indicated is as described in the construction specifications and drawings.

BIDDERS MUST FILL OUT THE TABLES BELOW COMPLETELY. Failure to complete and submit Attachment "N" – Schedule of Values may result in the bid proposal being deemed non-responsive and removed from consideration for award of a contract.

Signalization Component

Pay Item	Description	Total Quantity	Unit	Unit Price	Total Amount
630 - 2- 11	CONDUIT (F&I) (OPEN TRENCH)	195	LF	\$	\$
630 - 2- 12	CONDUIT (F&I) (DIRECTIONAL BORE)	430	LF	\$	\$
632 - 7- 1	SIGNAL CABLE (F&I) (NEW OR RECONSTRUCTED INTERSECTION)	1	PI	\$	\$
632 - 7- 6	SIGNAL CABLE (REMOVE-INTERSECTION)	1	PI	\$	\$
633 - 2- 32	FIBER OPTIC CONNECTION (INSTALL) (TERMINATION)	12	EA	\$	\$
633 - 3- 14	FIBER OPTIC CONNECTION HARDWARE (F&I) (BUFFER TUBE FAN OUT KIT)	1	EA	\$	\$
633 - 3- 16	FIBER OPTIC CONNECTION HARDWARE (F&I) (PATCH PANEL- FIELD TERMINATED)	1	EA	\$	\$
635 - 2- 11	PULL & SPLICE BOX (F&I) (13 "x 24 " COVER SIZE)	13	EA	\$	\$
635 - 2- 12	PULL & SPLICE BOX (F&I) (24 "x 36 " COVER SIZE)	1	EA	\$	\$
639 - 1- 122	ELECTRICAL POWER SERVICE (F&I) (UNDERGROUND) (PURCHASED)	1	AS	\$	\$
639 - 2- 1	ELECTRICAL SERVICE WIRE (F&I)	130	LF	\$	\$
641 - 2- 12	PRESTRESSED CONCRETE POLE (F&I) (TYPE P- II SERVICE POLE)	1	EA	\$	\$
641 - 2- 60	PRESTRESSED CONCRETE POLE (COMPLETE POLE REMOVAL- PEDESTAL/ SERVICE POLE)	1	EA	\$	\$
641 - 2- 70	PRESTRESSED CONCRETE POLE (SHALLOW POLE REMOVAL- POLE 30 ' AND GREATER)	4	EA	\$	\$
646 - 1- 11	ALUMINUM SIGNALS POLE (F&I) (PEDESTAL)	7	EA	\$	\$
649 - 21 - 10	STEEL MAST ARM ASSEMBLY (F&I) (SINGLE ARM 60 ')	1	EA	\$	\$
649 - 21 - 15	STEEL MAST ARM ASSEMBLY (F&I) (SINGLE ARM 70 ')	2	EA	\$	\$
649 - 21 - 21	STEEL MAST ARM ASSEMBLY (F&I) (SINGLE ARM 78 ')	1	EA	\$	\$

Pay Item	Description	Total Quantity	Unit	Unit Price	Total Amount
650 - 1- 14	VEHICULAR TRAFFIC SIGNAL (F&I - ALUMINUM) (3 SECTION) (1 WAY)	9	AS	\$	\$
650 - 1- 16	VEHICULAR TRAFFIC SIGNAL (F&I - ALUMINUM) (4 SECTION) (1 WAY)	4	AS	\$	\$
653 - 1- 11	PEDESTRIAN SIGNAL (F&I LED COUNTDOWN) (1 WAY)	6	AS	\$	\$
653 - 1- 12	PEDESTRIAN SIGNAL (F&I LED COUNTDOWN) (2 WAYS)	1	AS	\$	\$
660-4-11	VEHICLE DETECTION SYSTEM-VIDEO (F&I) (CABINET EQUIPMENT)	1	EA	\$	\$
660-4-12	VEHICLE DETECTION SYSTEM-VIDEO (F&I) (ABOVE GROUND EQUIPMENT)	4	EA	\$	\$
665 - 1- 11	PEDESTRIAN DETECTOR (F&I) (STANDARD)	8	EA	\$	\$
670 - 5- 111	TRAFFIC CONTROLLER ASSEMBLY (F&I) (NEMA) (1 PRE-EMPTION PLAN)	1	AS	\$	\$
670 - 5- 600	TRAFFIC CONTROLLER ASSEMBLY (REMOVE CONTROLLER AND CABINET)	1	AS	\$	\$
682 - 1- 133	ITS CCTV CAMERA (F&I) (DOME PTZ ENCLOSURE, NON-PRESSURIZED) (IP, HIGH DEFINITION)	1	EA	\$	\$
684 - 1- 1	MANAGED FIELD ETHERNET SWITCH (F&I)	1	EA	\$	\$
684 - 6- 11	WIRELESS COMMUNICATION DEVICE (F&I) (ETHERNET ACCESS POINT)	2	EA	\$	\$
685 - 1- 11	UNINTERRUPTIBLE POWER SUPPLY (F&I) (LINE INTERACTIVE)	1	EA	\$	\$
700 - 3- 201	SIGN PANEL (F&I OVERHEAD MOUNT) (UP TO 12 SF)	7	EA	\$	\$
700 - 5- 21	INTERNALLY ILLUMINATED SIGN (F&I OVERHEAD MOUNT) (UP TO 12 SF)	2	EA	\$	\$
700 - 5- 22	INTERNALLY ILLUMINATED SIGN (F&I OVERHEAD MOUNT) (12 TO 18 SF)	2	EA	\$	\$
Signalization Component Total:					\$

Roadway Component

Pay Item	Description	Total Quantity	Unit	Unit Price	Total Amount
700 - 1- 11	SINGLE POST SIGN (F&I GROUND MOUNT) (UP TO 12 SF)	1	AS	\$	\$
711 - 11 - 160	THERMOPLASTIC PAVEMENT MARKINGS (STANDARD) (WHITE) (MESSAGE OR SYMBOL)	2	EA	\$	\$
711 - 11 - 170	THERMOPLASTIC PAVEMENT MARKINGS (STANDARD) (WHITE) (ARROW)	1	EA	\$	\$
711 - 14 - 123	THERMOPLASTIC PAVEMENT MARKINGS (PREFORMED) (WHITE) (SOLID) (12 " FOR CROSSWALK)	799	LF	\$	\$
711 - 14 - 125	THERMOPLASTIC PAVEMENT MARKINGS (PREFORMED) (WHITE) (SOLID) (24 " FOR CROSSWALK)	684	LF	\$	\$
711 - 17	THERMOPLASTIC (REMOVE EXISTING THERMOPLASTIC PAVEMENT MARKINGS)	800	SF	\$	\$
Roadway Component Total:					\$

Pay Item	Description	Total Quantity	Unit	Unit Price	Total Amount
----------	-------------	----------------	------	------------	--------------

Lighting Component

Pay Item	Description	Total Quantity	Unit	Unit Price	Total Amount
630 - 2- 11	CONDUIT (F&I) (OPEN TRENCH)	50 .00	LF	\$	\$
630 - 2- 12	CONDUIT (F&I) (DIRECTIONAL BORE)	280 .00	LF	\$	\$
635 - 2- 11	PULL & SPLICE BOX (F&I) (13 "x 24 " COVER SIZE)	6	EA	\$	\$
715 - 1- 12	LIGHTING CONDUCTORS (F&I) (ISULATED) (NO. 8 - 6)	2,982 .00	LF	\$	\$
715 - 4- 13	LIGHT POLE COMPLETE (F&I STANDARD POLE STANDARD FOUNDATION) (40 ' MOUNTING HEIGHT)	3	EA	\$	\$
715 - 4- 31	LIGHT POLE COMPLETE (F&I UTI LI TY CONFLICT POLE) (INDEX 175 15 / 715 - 002 FOUNDATION) (30 ' MOUNTING HEIGHT)	1	EA	\$	\$
715 - 4- 70	LIGHT POLE COMPLETE (REMOVE POLE AND FOUNDATION)	2	EA	\$	\$
715 - 5- 32	LUMINAIRE & BRACKET ARM (F&I NEW LUMINAIRE AND ARM ON NEW/ EXISTING POLE) (GALVANIZED STEEL)	4	EA	\$	\$
715 - 500 - 1	POLE CABLE DISTRIBUTION SYSTEM (F&I) (CONVENTIONAL)	4	EA	\$	\$
Lighting Component Total:					\$

Project Components Subtotal:					\$
-------------------------------------	--	--	--	--	----

Non-Bid Component

Pay Item	Description	Total Quantity	Unit	Unit Price	Total Amount
101 - 1	MOBI LIZ ATI ON	10 .00	%		\$
102 - 1	MAI NTENANCE OF TRAFFI C	15 .00	%		\$
	CONTI NGENCY	10 .00	%		\$
Non-Bid Component Total:					

BID NO: 21-101

BID BOND

STATE OF FLORIDA
COUNTY OF ST. JOHNS

KNOW ALL MEN BY THESE PRESENTS, that _____ as Principal, and _____ as Surety, are held and firmly bound unto St. Johns County, Florida, in the penal sum of _____ Dollars (\$ _____) lawful money of the United States, we bind ourselves, our heirs, executors, administrators, and successors, jointly and severally, firmly by these presents.

THE CONDITION OF THIS OBLIGATIONS IS SUCH that whereas the Principal has submitted the accompanying Bid, dated _____, 20__.

For
SIGNALIZATION REPLACEMENT AT INTERSECTION OF US 1 / LEWIS POINT ROAD /
ST. AUGUSTINE SOUTH DRIVE - HMGP 4283-011-R
St. Johns County, Florida

NOW THEREFORE,

- (a) If the Principal shall not withdraw said Bid within ninety (90) days after Bid Award date, and shall within ten (10) days after prescribed forms are presented to him for signature, enter into a written Contract with the County in accordance with the Bid as accepted, and give Bond with good and sufficient Surety or Sureties, as may be required, for the faithful performance and proper fulfillment of such Contract, then the above obligations shall be void and of no effect, otherwise to remain in full-force and virtue.
- (b) In the event of the withdrawal of said Bid within the period specified, or the failure to enter into such Contract and give such Bond within the time specified, if the Principal shall pay the County the difference between the amount specified, in said Bid and the amount for which the County may procure the required Work and supplies, if the latter amount be in excess of the former, then the above obligations shall be void and of no effect, otherwise to remain in full force and virtue.

IN WITNESS WHEREOF, the above bounded parties have executed this instrument under their several seals, this day of _____ A.D., 20__, the name and corporate seal of each corporate party being hereto affixed and these presents duly signed by its undersigned representative, pursuant to authority of its governing body.

BID NO.: 21-101

WITNESSES:

(If Sole Ownership or Partnership two (2) Witnesses required).
(If Corporation, Secretary only will attest and affix seal).

WITNESSES:

PRINCIPAL:

NAME OF FIRM:

SIGNATURE OF AUTHORIZED
OFFICER (AFFIX SEAL)

TITLE

BUSINESS ADDRESS

CITY STATE

WITNESS:

SURETY:

CORPORATE SURETY

ATTORNEY-IN-FACT (AFFIX SEAL)

BUSINESS ADDRESS

CITY STATE

NAME OF LOCAL INSURANCE AGENCY

BID NO: 21-101

SPECIFICATIONS

BID NO: 21-101

PURPOSE:

The purpose of this Bid is for replacement of signalization at the intersection of US 1 (SR 5) and Lewis Point Road/St. Augustine South Drive in St. Johns County, Florida.

Funding for this project is through the Hazard Mitigation Grant Program (HMGP) as approved by the Florida Division of Emergency Management (Division) and the Federal Emergency Management Agency (FEMA).

The FEMA project number is HMGP4283-011-R, funded under FEMA-DR-4283-FL.

SCOPE OF WORK:

The Contractor shall be responsible for providing any and all labor, materials, and equipment required for replacement of signalization at the intersection of US 1 (SR 5) and Lewis Point Road/St. Augustine South Drive. This project includes replacing the existing strain pole and span wire signals with mast arms. All existing signal equipment, including the strain poles and span wires, will need to be removed and new signal equipment will need to be installed. This includes the installation of one mast arm on each corner, for a total of four mast arms. The intersection is to remain fully signalized throughout construction. In addition, this project includes the installation of new pedestrian features on each corner of the intersection. Miscellaneous improvements (lighting, conduit, pull boxes, controller cabinet, vehicle detection, etc.) will also be required.

General Notes

1. The Florida Department of Transportation standard plans and specifications (latest edition) shall be made a part of the plans and contract documents.
2. St. Johns County shall be informed any time the Contractor is on the job site performing construction should St. Johns County wish to have an inspector on the site. Contact Traffic Operations at (904) 209-0170.
3. The Contractor shall notify St. Johns County Traffic Operations at least 24 hours in advance of installing ground rods, installing underground conduit, setting poles, installing signal head assemblies, or cutting loops.
4. No polycarbonate housing or mounting hardware shall be permitted.
5. All signal heads shall be black aluminum.
6. At the time of final project inspection, the Contractor shall furnish two complete sets of signed and sealed "as-built" plans and complete documentation of any equipment and or hardware used for construction.
7. All conduit shall be 2-inch minimum, except electrical power service duct.
8. The Contractor shall verify color codes for signal cable with St. Johns County Traffic Operations prior to ordering cable.
9. St. Johns County retains the right to either accept or refuse removed equipment. If St. Johns County elects to refuse removed equipment, the Contractor will be responsible for all work and costs associated with the removal and disposal of equipment. All removed equipment that is being turned over to St. Johns County shall be delivered to a designated location set by St. Johns County.
10. One spare conduit shall be stubbed and capped in each of the pull boxes that has conduit to the cabinet.
11. Existing signalization shall remain in place to the extent possible and shall be used for maintenance of traffic, as required. Any maintenance of the existing signals (until removed) shall remain the responsibility of the Contractor.

12. Lane closures will not be permitted on weekends or holidays, nor will they be permitted during the hours of 7:00am to 11:00pm. St. Johns County and/or FDOT Traffic Operations may adjust these times to reflect actual field conditions.
13. When a lane closure is used an off-duty law enforcement officer shall direct traffic at the Contractor's expense. Off-duty law enforcement officers can be obtained from the office of the St. Johns County sheriff by contacting communications at (904) 810-6671.
14. Two manual pushbutton cords, two keys for the cabinet and two keys for the police panel door shall be furnished.
15. Unless specified otherwise, all pull box covers to furnished and installed shall be non-metallic and shall include the recessed logo "TRAFFIC SIGNALS". All fiber optic pull boxes shall be oversized to: 3 foot by 2.5 foot by 2 foot deep.
16. Detection, signal cable, interconnect, and electrical service wire shall be run in separate conduit and pull boxes.
17. The Contractor shall maintain the actuated operation of the signalized intersection throughout the life of the contract. Planned detection disruptions are not allowed. Any unplanned disruption to the vehicular detection system at signalized intersections shall be re-actuated within 24 hours. This will be at the Contractor expense.
18. St. Johns County Traffic Operations will approve any power service connections prior to installation and connection. If a service processing fee is required the fee shall be included as part of payment for electrical power service assembly by the Contractor and shall be responsible for the balance of the fee.
19. If a power meter is required the meter base shall be installed per FDOT Standard Plans Index 639-002 figure B or figure D and meet the FDOT Standard Specifications for Road and Bridge Construction 639 not attached to the signal poles or cabinet. The Contractor shall also use and install any equipment that meets the local utilities requirements.
20. All field wiring shall be neatly bundled and clearly identified with permanently legible, weatherproof tags that are securely attached to each cable. The tagging system proposed shall be submitted for approval by St. Johns County Traffic Operations.
21. Any equipment used for construction shall be submitted to St. Johns County Traffic Operations and the Engineer of Record for approval prior to ordering.
22. The Contractor shall be responsible for hand excavating to a depth of 5 feet each pole location to expose existing underground utilities and for coordinating with all utility companies prior to ordering the shop drawing for the mast arms. The Contractor should anticipate up to three excavations per location that may be required. The cost for hand excavating and temporarily backfilling the proposed foundation locations (prior to foundation construction) shall be included in the price for the mast arms.
23. The Contractor shall contact local utility companies to determine the location of underground utilities.
24. The Contractor installing mast arms shall not drill or otherwise modify mast arm bases or matching plates in order to "make it fit" without the Engineer of Record, FDOT (if a state roadway), St. Johns County, and the manufacture's approval in writing. Each reserve the right to deny the modification for any reason. It is the Contractor's responsibility to ensure the drilled shaft foundation, the mast arm and the mast arm base are built correctly.
25. All signal and pedestrian indications shall have L.E.D. displays. Pedestrian indications shall have a count down timer.
26. A green colored No. 6 AWG insulated stranded copper wire shall be connected between each of the intersection metal mast arm and pedestrian pole ground rod connection points and then to the controller ground bus. This wire

shall be pulled in the same conduit as the signal cable.

27. Each pole and mast arm shall be identified with a permanent 1-inch high engraved or impressed mark which contains all required identification information.
28. Once the signal heads are installed, the Contractor shall bag each head. The proposed bagging material shall be durable and designed for long-term application. No plastic garbage bags or tape shall be used.
29. The Contractor shall ensure all equipment installed is compatible with St. Johns County's existing equipment and software per site.
30. A No. 14 AWG insulated stranded copper wire shall be pulled in the same conduit as the fiber optic cable. Pull box to pull box and not into the cabinet.
31. The traffic signal heads shall be mounted vertical.
32. The Contractor shall use a Florida registered and FDOT prequalified geotechnical engineering firm for testing and QA/QC including but not limited to drilled shaft inspection with cross sonic logging, concrete slump and temperature.
33. The Contractor shall notify the Engineer of Quality Control testing locations and times at least one business day prior. The Contractor shall provide the Engineer and FDOT a copy of test results and reports within one business day of receipt.
34. The Contractor shall have a FDOT certified temporary traffic control specialist during mot setup, breakdown and daily maintenance. The Contractor shall notify the Engineer and FDOT of any required lane closures at least one week prior.
35. The Contractor shall provide a staging area for all materials. No materials or equipment shall be stored within the right-of-way.
36. All excavators are required to contact the sunshine state one call of Florida, phone number 1 (800) 432-4770 or 811 a minimum of two working days (excluding weekends) in advance of commencement of excavation to ensure facilities are located accurately.
37. Conduct all locations and excavations in accordance with the Florida Statute 556 of the underground facilities damage prevention & safety act and all local city and county ordinances that may apply.
38. All areas of disturbed existing or proposed city, county, or state right-of-way shall be sodded.
39. The Engineer of Record shall be given forty-eight hours (48 hours) notice of all meetings and or testing measures related to said project.
40. Existing utilities shown are located according to the information available to the Engineer at the time and have not been independently verified by the Owner or Engineer. Guarantee is not made that all existing underground utilities are shown or that the location of those shown are entirely accurate. Finding the actual location of any existing utilities is the Contractor's responsibility and shall be done before he/she commences any work in the vicinity. Furthermore, the Contractor shall be fully responsible for any and all damages due to the Contractor's failure to exactly locate and preserve any and all underground utilities. The Owner or Engineer will assume no liability for any damages sustained or cost incurred because of the operations in the vicinity of existing utilities or structures, nor for temporary bracing and shoring of same.
41. The Contractor is responsible for any damage to existing utilities, survey monuments, markers, corners, and existing features in the area. Any damage shall be replaced/repared by the Contractor at no additional expense to the owner.

42. The Contractor shall be responsible for traffic signal head alignment and location for interim mot and final inspections. St. Johns County nor FDOT shall be charged to adjust the heads as required.
43. Removal of pavement markings shall not significantly alter the pavement texture.
44. The Contractor shall have a certified IMSA roadway lighting technician and traffic signal construction technician on site overseeing the signal installation.
45. The Contractor shall schedule an inspection with FDOT at 90% completion of construction.
46. All associated equipment shall be compatible with the St. Johns County Traffic Management Center's Trafficware ATMS.now central software.
47. The Contractor shall keep one crosswalk open in each direction, at all times, in order to maintain pedestrian access.
48. Prior to performing work within the US 1 (SR 5) right-of-way, the Contractor shall notify FDOT employee Christopher Pogue at (904) 825-5086

Pay Item Notes

- Pay Item 641-2-70: Shall include the cost to restore the damaged sidewalk from the removal of existing concrete strain poles.
- Pay items 660-4-11 and 660-4-12: Camera V1 shall be Gridsmart Smartmount Kit with Camera (GS-3-SMK). Cameras V2 and V6 shall be Gridsmart Advanced Camera Fiber (GS-3-SMA-F). Contact Cubic at 904-613-9331 to arrange for order and installation.
- Pay Item 670-5-111: Shall be Trafficware Group Wired Cabinet Assembly TS-2 size 6 cabinet with Trafficware Group TS-2 Type 2 Model 981-A1100 controller with Ethernet.
- The existing concrete base shall be reused. The existing conduits for electric, 12 mm fiber optic cable, loop detection, and fire station preemption shall be retained. There is no available slack in the existing 12 mmfo or preemption. The loop detection will not be wired to the new controller but will be left intact for future accessibility. New conduits for signal cable, lighting, and wireless magnetometer detection shall be drilled into open space in existing concrete base.
- Pay Item 684-1-1: Shall be ITS Express 8040 switch.
- Pay Item 684-6-11: Shall be Ubiquiti Networks Nano Station M Model NSM5.
- Pay Item 685-1-11: Shall be temple model FXM 2000. System shall be installed and housed in a separate cabinet from the traffic controller cabinet assembly.

Directional Bore Notes

1. When performing a horizontal directional drilling (HDD) operation, the utility/agency owner (UAO) shall restrict the bored diameter to the maximum diameter allowed for the diameter of the utility being installed. The utility diameter is the casing diameter when casing is used. For utility diameters less than eight (8) inches, the maximum bored diameter is equal to the utility diameter plus four (4) inches. For utility diameters of eight (8) inches to twenty-four (24) inches, the maximum bored diameter is equal to one and one half (1.5) times the utility diameter. For utility diameters greater than twenty-four (24) inches, the maximum bored diameter is equal to the utility diameter plus one (1) foot. Where a utility has restrained joints the maximum bored diameter shall be the manufacturer's recommended diameter. Additionally, the UAO should maintain a clearance, from any existing vitrified clay

sanitary pipe line or existing gas lines, of at least three and one half (3.5) times the bored diameter.

2. When boring under roadway pavement, the UAO shall maintain a bore depth of at least ten (10) times the bored diameter or 30 inches, whichever is greater, as measured from the top of pavement to the top of the bore. The UAO may reduce this depth by determining the water table anticipated at time of installation or a confining layer. The confining layer is a two (2) feet thick layer of earth that resists thirty (30) blows per foot of a standard penetration test. If either of these is determined, the bore depth may be reduced to two (2) feet below the top of the confining layer to the top of the bore, or two (2) feet below the top of the water table to the top of the bore. Additionally, the UAO should maintain a clearance, from any existing vitrified clay sanitary pipe line or existing gas lines, of at least three and one half (3.5) times the bored diameter.
3. The UAO shall also do all of the following:
 - 1) Determine orientation and tracking of the drill bit.
 - 2) Utilize relief holes as necessary to relieve excess pressure down hole.
 - 3) Prevent heaving during pull back.
 - 4) Keep the drill pipe in the bore hole until the final product is pulled into place.
 - 5) When boring under roadway pavement, install the product into a bore hole within the same day that the pre-bore is completed

Utility Notes

1. The location(s) of the utilities shown in the plans (including those designated Vv, Vh, and Vvh) are based on limited investigation techniques and should be considered approximate only. The verified locations/elevations apply only at the points shown. Interpolations between these points have not been verified.
2. All FPL overhead electrical facilities to remain energized and in place. Table a minimum clearance distances specified in Subpart CC of OSHA Rule 29 CFR Part 1926 (as they pertain to crane/derrick operations), and/or those minimum distances specified in 29 CFR 1910.333(c)(3) for work in proximity to power lines not covered by Subpart CC, must be maintained. The Contractor shall coordinate with FPL and Engineer of Record to confirm minimum clearance distances from overhead electric facilities.
3. Utility agency owners per dig ticket:

FPL Electric	(800) 468-8243
Centurylink.	(352) 303-2430
Teco Gas	(813) 228-1351
AT&T Comm.	(561) 997-0240
St. Johns County Water & Sewer	(904) 209-2701
Uniti Fiber	(904) 718-8152

St. Johns County Traffic Signal and ITS Equipment Preferences

1. The traffic signal contract shall provide all interconnectivity with the County ATMS.now software.
2. All associated equipment shall be compatible with our Traffic Management Center's Trafficware ATMS.now central software and include the following:
 - Trafficware Group Wired Cabinet Assembly TS-2 Size 6 cabinet with Trafficware Group Controller-NEMA TS2 to include rear access door.
 - Trafficware Group TS2 Type 2 Model 981-A1100 controller with Ethernet.
 - Trafficware Group Malfunction Management Unit Type 16 Model MMU-516L.
 - Uninterruptable Power Source (UPS) shall be a Temple Uninterruptible Power Supply Model FXM 2000. System shall be installed housed in a separate cabinet from the traffic controller cabinet assembly.
 - Fiber optic Ethernet switch shall be ITS Express Managed Field Ethernet Switch Model 8040.
 - Design should include a camera for monitoring of the intersection: Bosch VG5 Autodome with Ethernet connection.

3. LED internally illuminated street name signs.
4. Mast Arm assemblies shall have a galvanized finish.
5. Pedestrian assemblies installed with transformer base and aluminum pole.
6. Design should include LED luminaries on the mast arm (Autobahn Series ATBL).

The following items on the Approved Products List are requested to be included in the installation:

- **Trafficware Group, Malfunction Management Unit Type 16**
Supplier: Trafficware Group, Inc.
 - **Model Number:** MMU-516L
 - **APL Certification Number:** 678-016-007
 - **Comment:** Note: Re-evaluated new firmware v2.05 with Flashing Yellow Arrow Operation
- **Trafficware Group, Controller - NEMA TS2 Type 2**
Supplier: Trafficware Group, Inc.
 - **Model Number:** 981-A1100
 - **APL Certification Number:** 671-017-003
 - **Comment:** (NAZTEC)
- **Trafficware Group, Wired Cabinet Assembly TS-2 Size 6**
Supplier: Trafficware Group, Inc.
 - **Model Number:** 70006-TS2/FL
 - **APL Certification Number:** 676-023-004
 - **Comment:** Note: Reviewed and Approved Automatic Transfer Switch and Generator Connection on May 25, 2006. || Reviewed and approved Automatic Transfer Switch and Generator Connection on 5-25-2006 || Reviewed and approved updated printed circuit modules, solid state relays, LED lighting and nylon rollers on 8-15-2014
- **ITS Express, Managed Field Ethernet Switch**
Supplier: ITS Express
 - **Model Number:** ITS Express 80XX Series
 - **APL Certification Number:** 684-002-007
 - **Comment:** (Models included in series: ITS-8040, ITS-8012, and ITS-8020+) (Model Tested: ITS-8040 with Firmware Version 1.17) (includes old certification #:78461201219013)
- **Bosch Security Systems, Camera - Dome**
Supplier: Bosch Security Systems, Inc.
 - **Model Number:** VG5-ITS Autodome Series
 - **APL Certification Number:** 682-002-004
 - **Comment:** 5/5/2015 update: Model tested: VG5-ITS720P-30X4; Firmware Version: 5.92.0090, Includes old certification #:78260400219013

EXHIBIT A

REPORT OF GEOTECHNICAL EXPLORATION TRAFFIC SIGNAL MAST ARM DESIGN

(SEPARATE ATTACHMENT)

EXHIBIT B

SIGNALIZATION PLANS

(SEPARATE ATTACHMENT)

SEALED BID MAILING LABEL

BID NO: 21-101

**Cut along the outer border and affix this label
to your sealed bid envelope to identify it as a
"Sealed BID"**

SEALED BID • DO NOT OPEN	
SEALED BID NO.:	BID NO: 21-101
BID TITLE:	Signalization Replacement at Intersection of US 1 / Lewis Point Road / St. Augustine South Drive – HMGP 4283-011-R
DUE DATE/TIME:	By 2:00PM – July 21, 2021
SUBMITTED BY:	Company Name
	Company Address
	Company Address
DELIVER TO:	St. Johns County Purchasing Dept. 500 San Sebastian View St St. Augustine FL 32084



END OF DOCUMENT

**BID NO.: 21-101; SIGNALIZATION REPLACEMENT AT INTERSECTION OF US 1 / LEWIS POINT
ROAD / ST. AUGUSTINE SOUTH DRIVE – HMGP 4283-011-R**

EXHIBIT A

**REPORT OF GEOTECHNICAL EXPLORATION
TRAFFIC SIGNAL MAST ARM DESIGN**

**Report of Geotechnical Exploration
for Mast Arm Foundation Structures**

For

**St. Johns County Signal Rebuilds
US Highway 1 & Lewis Point Road
St. Johns County, Florida**

*MAE Project No. 0013-0004B
June 22, 2018*

Prepared for:



**Kimley-Horn
and Associates, Inc.**

Kimley-Horn & Associates, Inc.
12740 Grand Bay Parkway West, Suite 2350
Jacksonville, Florida 32258

Prepared by:



Meskel & Associates Engineering, LLC
8936 Western Way, Suite 12
Jacksonville, Florida 32256
Phone (904) 519-6990
Fax (904) 519-6992



June 22, 2018

Ms. Michelle B. Mecca, P.E.
Kimley Horn
12740 Grand Bay Parkway West, Suite 2350
Jacksonville, FL 32258

Brett Harbison, State of Florida, Professional Engineer, License No. 74679. This item has been electronically signed and sealed by Brett Harbison, P.E. on 06/22/2018 using a Digital Signature. Printed copies of this document are not considered signed and sealed and the signature must be verified on any electronic copies.

Reference: Final Report of Geotechnical Exploration- Miscellaneous Structures
St. Johns County Signal Rebuilds – US Highway 1 & Lewis Point Road
St. Johns County, Florida
MAE Project No. 0013-0004B

Dear Ms. Mecca:

MESKEL & ASSOCIATES ENGINEERING, PLLC (MAE) has completed a geotechnical exploration for the mast arm foundations associated with the subject project. Our work was performed in general accordance with the Individual Project Order Number 02 pursuant to the Master Agreement for Continuing Professional Services between Kimley-Horn & Associates, Inc. (Kimley-Horn) and MAE dated April 18, 2018.

This report presents our understanding of the proposed of mast arm signal pole structures, as shown on the project plans provided to us. This report describes the field exploration and laboratory testing programs, and presents the data obtained from the field. Our field exploration was performed in general accordance with FDOT procedures to evaluate the general subsurface conditions within the proposed structure areas.

Based on our findings, it is our opinion that the encountered subsurface conditions are suitable for support of the mast arm structures. Soil parameters that can be used for design are shown on Table 3 in Appendix C.

We appreciate this opportunity to be of service as your geotechnical consultant on this phase of the project. If you have any questions concerning this report or if we may be of any further service at this time, please contact me.

Sincerely,

MESKEL & ASSOCIATES ENGINEERING, PLLC
MAE FL Certificate of Authorization No. 28142

W. Josh Mele, E.I.
Staff Engineer

Brett H. Harbison, P.E.
Director, Geotechnical Services
Licensed, Florida No. 74679

Distribution: Ms. Michelle B. Mecca, P.E. – Kimley-Horn

1 pdf

TABLE OF CONTENTS

Subject	Page No.
1.0 PROJECT INFORMATION	1
1.1 Site Location	1
1.2 Project Description	1
1.3 Purpose and Scope of Study	1
2.0 FIELD EXPLORATION	1
3.0 LABORATORY TESTING	2
3.1 Visual Classification	2
3.2 Index Tests	2
3.3 Corrosions Series Tests	2
4.0 SITE AND SUBSURFACE CONDITIONS	2
4.1 General Soil Stratigraphy	2
4.2 General Subsurface Conditions	3
4.3 Groundwater Level	3
5.0 CONCLUSIONS AND RECOMMENDATIONS	3
5.1 Drilled Shaft Structure Recommendations	3
5.2 Environmental Classification	3
6.0 REPORT LIMITATIONS	4

FIGURES

- Figure 1. Site Vicinity/Topographic Map
- Figure 2. Soil Survey Map
- Figure 3. Report of Core Borings Mast Arm Structures

APPENDICES

- Appendix A. Field Exploration Procedures
 - Key to Boring Logs
 - Key to Soil Classification
- Appendix B. Table 1: Summary of Laboratory Index Tests for Mast Arm Structures
 - Table 2: Summary of Corrosion Series Test Results for Mast Arm Structures
 - Laboratory Test Procedures
- Appendix C. Table 3: Soil Design Parameters for Mast Arm Structures (Borings B-1 & B-2)

1.0 PROJECT INFORMATION

1.1 Site Location

The St. Johns County Signal Rebuild Project is located at the intersection of US Highway 1 (US 1) and Lewis Point Road in St. Johns County, Florida. The general project location is shown on the Site Vicinity/Topographic Map, which is superimposed on the St. Augustine Beach, FL USGS 7.5" Topo, and on the Soil Survey Map presented as Figures 1 and 2, respectively.

1.2 Project Description

Project information for the proposed mast arm structure foundations has been provided to us in discussions with you. It is our understanding that the existing strain pole structures at each corner of the intersection will be replaced with mast arm foundations.

The locations of the two mast arm signal pole structures that are to be constructed on the northwest and southeast corners of the US 1 and Lewis Point Road intersection as shown on the *Report of Core Borings Mast Arm Structures* sheet, Figure 3. These structures are anticipated to be supported by a drilled shaft foundation designed and constructed in accordance with FDOT specifications. This report focuses only on the field data that was encountered during our field exploration for the miscellaneous structures.

1.3 Purpose and Scope of Study

The purpose of this study was to explore the subsurface conditions within the proposed miscellaneous structure areas. This exploration was performed to provide field data to guide design and construction of the structures. We accomplished these purposes by:

1. Reviewing aerial photographs and published data such as USGS Quadrangle Maps and USDA Soil Survey Maps.
2. Locating soil borings in the area of the planned structures subject to any conflicts with underground or overhead utilities.
3. Performing Standard Penetration Test (SPT) borings, obtaining soil samples and measuring groundwater levels encountered at the boring locations.
4. Classifying the recovered soil samples and performing tests in the laboratory on selected samples to aid in classification.
5. Analyzing and interpreting the field and laboratory test data.
6. Performing engineering analyses and estimating soil parameters for design of the proposed drilled shaft structures.

2.0 FIELD EXPLORATION

A field exploration was performed on June 7, 2018 and consisted of locating a SPT boring at each of the proposed structures. Two (2) Standard Penetration Test (SPT) borings were performed to an approximate depth of 25 feet below existing grade. The SPT borings were advanced in general accordance with the methodology outlined in ASTM D1586. However, the borings were initially advanced using a hand auger



to a depth of 4 feet for safety concerns due to near-by existing underground utilities. A static cone penetrometer was used to record soil resistance in the upper 4 feet.

The test locations were located in the field using taped measurements from existing roadways and were adjusted in the field based on existing marked underground and overhead utilities and site features. Therefore, the boring locations, as shown on the *Report of Core Borings Mast Arm Structures* sheet (Figure 3), should be considered approximate.

Boring depths for the Mast Arm Structures were determined in accordance with the edition of the FDOT's *Soils and Foundations Handbook* that was available at the time of the field exploration. Split-spoon soil samples recovered during performance of the borings were transported to the laboratory for further evaluation.

3.0 LABORATORY TESTING

3.1 Visual Classification

Representative soil samples obtained during our field exploration of the structure areas were packaged and transferred to our laboratory for classification using the USCS Soil Classification System in general accordance with ASTM D 2487. A summary of the soil classification and corresponding soil descriptions are shown on the *Report of Core Borings Mast Arm Structures* sheet presented as Figure 3.

3.2 Index Tests

Quantitative laboratory testing was performed on selected samples of the soils encountered during the field exploration. The laboratory testing was performed to better define the composition of the soils encountered, and to help determine their suitability to support the planned drilled shaft foundations. The laboratory testing determined the percent fines and natural moisture content of the selected soil samples. The results of the laboratory testing are presented on the *Summary of Laboratory Index Tests for Mast Arm Structures*, Table 1. The test results are also summarized on the *Report of Core Borings Mast Arm Structures* sheet, Figure 3.

3.3 Corrosions Series Tests

A bulk soil sample was collected for corrosion property testing at the intersection near Boring B-1. The testing included pH, resistivity, and chloride and sulfate contents. The test results are discussed in Section 5.3 below. The test results are presented on the *Summary of Corrosion Series Test Results for Mast Arm Structures*, Table 2, and on the *Report of Core Borings Mast Arm Structures* sheet, Figure 3.

4.0 SITE AND SUBSURFACE CONDITIONS

4.1 General Soil Stratigraphy

The results of the field exploration and laboratory index testing are graphically presented on the *Report of Core Borings Mast Arm Structures* sheet, Figure 3. Stratification of the encountered soils is based on observation of the recovered soil samples in the field, laboratory classification and testing, and interpretation of the field boring logs by a geotechnical engineer. Stratification lines represent

approximate boundaries between soil types; however, the actual transition between layers may be more gradual than implied.

4.2 General Subsurface Conditions

In general, the borings encountered loose to very dense, poorly graded fine sand (SP) and fine sand with silt (SP-SM) to the boring termination depth of approximately 25 feet below existing grade. Soil profiles for the borings are shown on the *Report of Core Borings Mast Arm Structures*, Figure 3.

4.3 Groundwater Level

The groundwater level was encountered at each of the borings at the time of drilling. Groundwater was measured at depths of approximately 2.5 to 3 feet below existing grade at Borings B-1 and B-2. It should be anticipated that the groundwater level will fluctuate due to seasonal weather changes, surface water runoff patterns, construction operations, and other interrelated factors. The depths to the measured groundwater levels are shown on the attached Figure 3.

5.0 CONCLUSIONS AND RECOMMENDATIONS

Our geotechnical engineering evaluation of the site and subsurface soil conditions is based on the results of our geotechnical field exploration, the laboratory test data obtained, and our understanding of the project information and structural conditions as presented in this report.

Should the location of the structures be changed, a review of our recommendations will be required. Also, the discovery of any site or subsurface conditions during construction that deviates from the data obtained during this geotechnical exploration should also be reported to us for our evaluation.

5.1 Drilled Shaft Structure Recommendations

Based on the results of the borings performed for the proposed mast arm signal pole structures, we consider the subsurface conditions at each boring to be favorable for support of the proposed structures, when constructed according to FDOT specifications. Soil parameters, which can be used in design for the proposed structures, were estimated based on the encountered subsurface conditions and are presented on Table 3 included in Appendix C. These parameters are based on empirical correlations between average SPT N-values and various soil properties.

For design purposes, we recommend that groundwater be assumed at existing grade. We recommend a value of 0.35 be used for the concrete/soil interface coefficient of friction in the design of the foundations. The installation of the drilled shaft structures should be performed in accordance with the latest edition of the FDOT *Standard Specifications for Road and Bridge Construction*.

5.2 Environmental Classification

One soil corrosion series test was performed on a bulk soil sample obtained near Boring B-1 to determine the environmental classification of the encountered soils. The samples were classified in accordance with FDOT procedures contained in Chapter 1.3.2.1 of the latest edition of the FDOT *Structures Design Guidelines*. Based on the results of these tests, the subsurface soils are considered Slightly Aggressive for steel and Slightly Aggressive for concrete. These results are generally due to the measured pH value. Sample locations and test results are shown in Table 2 and on Figure 3.

6.0 REPORT LIMITATIONS

This report has been prepared for the exclusive use of Kimley-Horn and St. Johns County for specific application to the design and construction of the St. Johns County Signal Rebuilds Project at US Highway 1 and Lewis Point Road. All work for this project was performed in accordance with generally accepted geotechnical engineering practice. No warranty, expressed or implied, is made.

The scope of our services does not include any environmental assessment or testing for the presence or absence of hazardous or toxic materials in the soil, groundwater, or surface water within or beyond the subject site. Any statements made in this report, and/or notations made on the generalized soil profiles or boring logs, regarding odors or other potential environmental concerns are based on observations made during execution of our scope of services and as such are strictly for the information of our client. No opinion of any environmental concern of such observations is made or implied. Unless complete environmental information regarding the site is already available, an environmental assessment is recommended.

The analyses and recommendations contained in this report are based on the data obtained from the borings performed at this site for this project. This testing indicates subsurface conditions only at the specific location and time, and only to the depth explored. These results do not reflect subsurface variations that may exist away from the boring location and/or at depths below the boring termination depth. Subsurface conditions and water levels at other locations may differ from conditions occurring at the tested location. In addition, it should be understood that the passage of time may result in a change in the conditions at the tested location. If variations in subsurface conditions from those described in this report are observed during construction, the recommendations in this report must be re-evaluated.

Figures

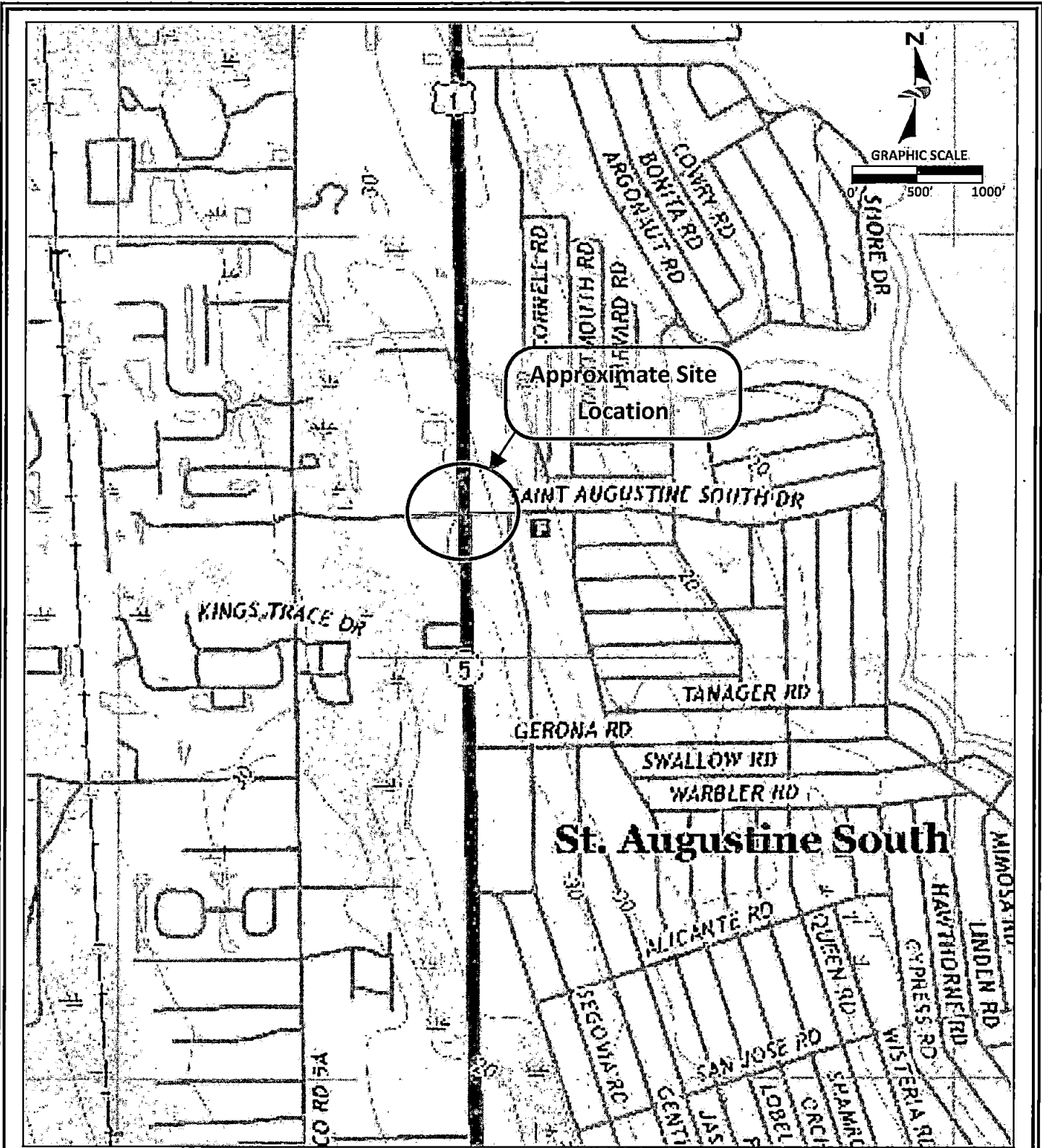

Site Vicinity / Topographic Map

PREPARED BY	PROJECT NAME	
Meskel & Associates Engineering, PLLC FL Certificate of Authorization No. 28142 8936 Western Way, Suite 12, Jacksonville, FL 32256	St. Johns County Signal Rebuilds -US 1 & Lewis Point Road St. Johns County, Florida	
PREPARED FOR	REFERENCE	SCALE
Kimley Horn	USGS 7.5" Saint Augustine Beach FL Quadrangle	1" = 1000'
	MAE PROJECT NO.	FIGURE NO.
	0013-004B	1

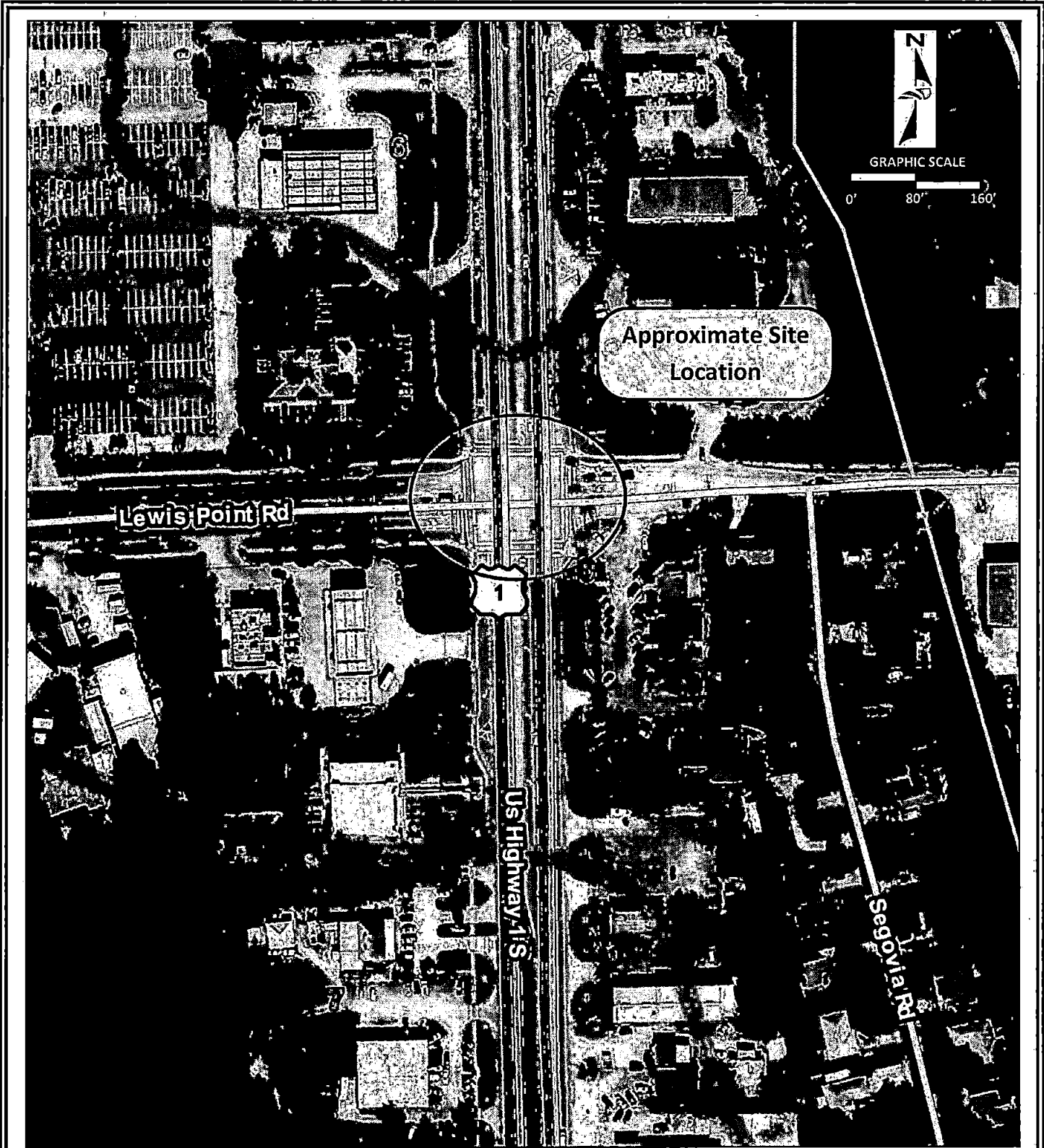

Soil Survey Map

<small>PREPARED BY:</small> Meskel & Associates Engineering, PLLC FL Certificate of Authorization No. 28142 8936 Western Way, Suite 12, Jacksonville, FL 32256	<small>PROJECT NAME:</small> St. Johns County Signal Rebuilds -US 1 & Lewis Point Road St. Johns County, Florida				
<small>PREPARED FOR:</small> Kimley Horn	<table border="1" style="width: 100%; border-collapse: collapse;"> <tr> <td style="width: 50%;"><small>REFERENCE:</small> NRCSS</td> <td style="width: 50%;"><small>SCALE:</small> 1" = 160'</td> </tr> <tr> <td><small>MAE PROJECT NO.:</small> 0013-00048</td> <td><small>FIGURE NO.:</small> 2</td> </tr> </table>	<small>REFERENCE:</small> NRCSS	<small>SCALE:</small> 1" = 160'	<small>MAE PROJECT NO.:</small> 0013-00048	<small>FIGURE NO.:</small> 2
<small>REFERENCE:</small> NRCSS	<small>SCALE:</small> 1" = 160'				
<small>MAE PROJECT NO.:</small> 0013-00048	<small>FIGURE NO.:</small> 2				

LOCATION PLAN

B-1



APPROXIMATE LOCATION OF STANDARD PENETRATION TEST BORING

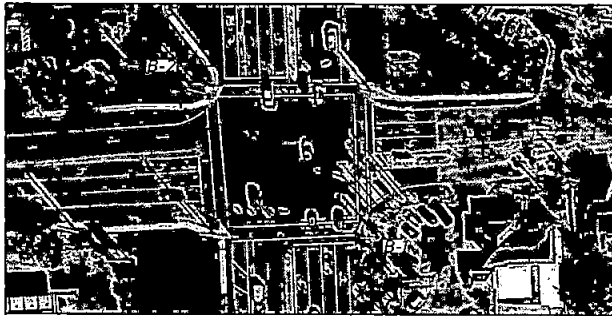
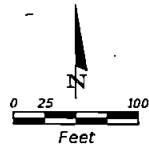

NOTE: PLAN AS SHOWN IS PRELIMINARY FOR REPRESENTATION OF BORING LOCATION ONLY AND MAY NOT BE INDICATIVE OF FINAL CONTRACT PLANS.

LEGEND

- SAND WITH SILT
- SAND
- LIMEROCK
- TOPSOIL
- (SP) UNIFIED SOIL CLASSIFICATION SYSTEM SYMBOL
- ENCOUNTERED GROUNDWATER LEVEL MEASURED AT TIME OF DRILLING
- NATURAL MOISTURE CONTENT (W) FINES PASSING No. 200 SIEVE (F)
- N STANDARD PENETRATION RESISTANCE IN BLOWS PER FOOT
- N* EQUIVALENT STANDARD PENETRATION RESISTANCE VALUE CONVERTED FROM STATIC HAND CONE PENETROMETER READINGS
- BT BORING TERMINATION DEPTH
- HA BORING ADVANCED WITH HAND-HELD BUCKET AUGER DUE TO POSSIBLE UNDERGROUND UTILITIES.
- 50/5.5" INDICATES 50 HAMMER BLOWS DROVE SLIP SPOON SAMPLER 5.5 INCHES.

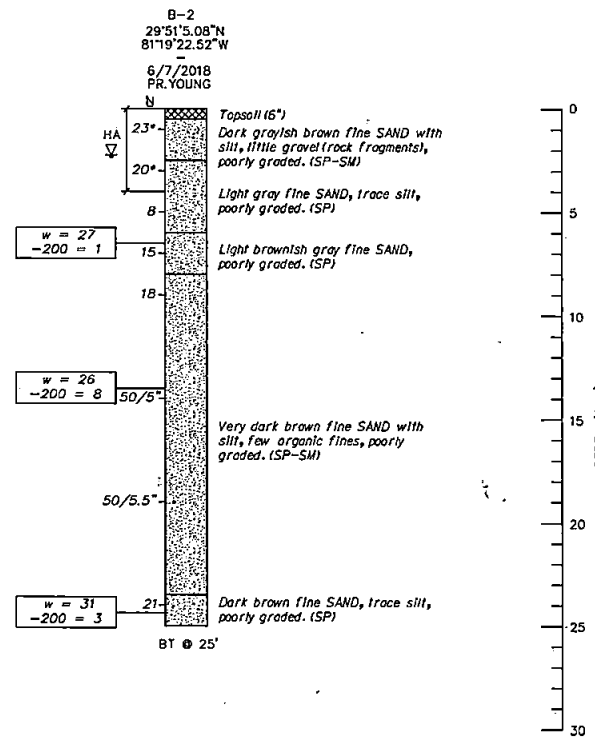
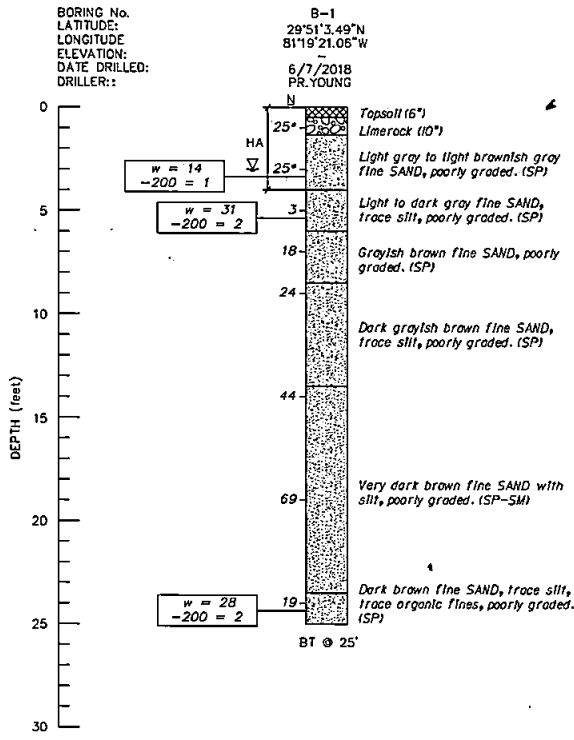

STANDARD PENETRATION TEST DATA

SPOON INSIDE DIA.	1.375 IN.
SPOON OUTSIDE DIA.	2 IN.
AVG. HAMMER DROP	30 IN.
HAMMER WEIGHT	140 LBS.

GRANULAR MATERIALS	
RELATIVE DENSITY	SPT (BLOWS/FT.)
VERY LOOSE	LESS THAN 3
LOOSE	3-8
MEDIUM DENSE	8-24
DENSE	24-40
VERY DENSE	GREATER THAN 40

SILTS AND CLAYS	
CONSISTENCY	SPT (BLOWS/FT.)
VERY SOFT	LESS THAN 1
SOFT	1-3
FIRM	3-6
STIFF	6-12
VERY STIFF	12-24
HARD	GREATER THAN 24

ENVIRONMENTAL CLASSIFICATION:

SUBSTRUCTURE: CONCRETE: SLIGHTLY AGGRESSIVE
 STEEL: SLIGHTLY AGGRESSIVE

RIG TYPE: CHE 45B
 HAMMER TYPE: AUTOMATIC HAMMER

NOTES:

- 1) LAYER BOUNDARIES ARE APPROXIMATE AND REPRESENT SOIL LAYERS AT EACH TEST HOLE LOCATION ONLY; SUBSURFACE VARIATIONS BETWEEN BORINGS SHOULD BE ANTICIPATED.
- 2) LATITUDE AND LONGITUDE WERE OBTAINED USING HAND-HELD GPS DEVICE (GARMIN GPSMAP 78) AT THE TIME OF DRILLING AND ARE CONSIDERED APPROXIMATE.

REVISIONS			
DATE	DESCRIPTION	DATE	DESCRIPTION

BRETT H. HARBISON, P.E.
 FLORIDA PE NO. 74679
 MESKEL & ASSOCIATES ENGINEERING, PLLC
 8936 WESTERN WAY, SUITE 12,
 JACKSONVILLE, FL 32256
 CERTIFICATE OF AUTHORIZATION NO. 28142

KINLEY HORN 12740 GRAN BAY PARKWAY W, SUITE 2550 JACKSONVILLE, FLORIDA 32228		
ROAD NO.	COUNTY	MAE PROJECT NO.
US-1	ST. JOHNS	0013-0004B

REPORT OF CORE BORINGS
 MAST ARM STRUCTURES

SHEET NO.
 3

Appendix A

FIELD EXPLORATION PROCEDURES

Standard Penetration Test (SPT) Borings

The Standard Penetration Test (SPT) boring(s) were performed in general accordance with the latest revision of ASTM D 1586, "Standard Test Method for Standard Penetration Test (SPT) and Split-Barrel Sampling of Soils." The borings were advanced by rotary drilling techniques. A split-barrel sampler was inserted to the borehole bottom and driven 18 to 24 inches into the soil using a 140-pound hammer falling an average of 30 inches per hammer blow. The number of hammer blows for the final 12 inches of penetration (18" sample) or for the sum of the middle 12 inches of penetration (24" sample) is termed the "penetration resistance, blow count, or N-value." This value is an index to several in-situ geotechnical properties of the material tested, such as relative density and Young's Modulus.

After driving the sampler, it was retrieved from the borehole and representative samples of the material within the split-barrel were containerized and sealed. After completing the drilling operations, the samples for each boring were transported to the laboratory where they were examined by a geotechnical engineer to verify the field descriptions and classify the soil, and to select samples for laboratory testing.

KEY TO BORING LOGS – USCS

Soil Classification

Soil classification of samples obtained at the boring locations is based on the Unified Soil Classification System (USCS). Coarse grained soils have more than 50% of their dry weight retained on a #200 sieve. Their principal descriptors are: sand, cobbles and boulders. Fine grained soils have less than 50% of their dry weight retained on a #200 sieve. They are principally described as clays if they are plastic and silts if they are slightly to non-plastic. Major constituents may be added as modifiers and minor constituents may be added according to the relative proportions based on grain size. In addition to gradation, coarse-grained soils are defined on the basis of their in-place relative density and fine-grained soils on the basis of their consistency.

BORING LOG LEGEND	
Symbol	Description
N	Standard Penetration Resistance, the number of blows required to advance a standard spoon sampler 12" when driven by a 140-lb hammer dropping 30".
WOR	Split Spoon sampler advanced under the weight of the drill rods
WOH	Split Spoon sampler advanced under the weight of the SPT hammer
50/2"	Indicates 50 hammer blows drove the split spoon 2 inches; 50 Hammer blows for less than 6-inches of split spoon driving is considered "Refusal".
(SP)	Unified Soil Classification System
-200	Fines content, % Passing No. 200 U.S. Standard Sieve
w	Natural Moisture Content (%)
OC	Organic Content (%)
LL	Liquid Limit
PI	Plasticity Index
NP	Non-Plastic
PP	Pocket Penetrometer in tons per square foot (tsf)

MODIFIERS	
SECONDARY CONSTITUENTS (Sand, Silt or Clay)	
Trace	Less than 5%
With	5% to 12%
Sandy, Silty or Clayey	12% to 35%
Very Sandy, Very Silty or Very Clayey	35% to 50%
ORGANIC CONTENT	
Trace	Less than 5%
Organic Soils	5% to 20%
Highly Organic Soils (Muck)	20% to 75%
PEAT	Greater than 75%
MINOR COMPONENTS (Shell, Rock, Debris, Roots, etc.)	
Trace	Less than 5%
Few	5% to 10%
Little	15% to 25%
Some	30% to 45%

RELATIVE DENSITY (Coarse-Grained Soils)	
Relative Density	N-Value *
Very Loose	Less than 3
Loose	3 to 8
Medium Dense	8 to 24
Dense	24 to 40
Very Dense	Greater than 40
CONSISTENCY (Fine-Grained Soils)	
Consistency	N-Value *
Very Soft	Less than 1
Soft	1 to 3
Firm	3 to 6
Stiff	6 to 12
Very Stiff	12 to 24
Hard	Greater than 24
RELATIVE HARDNESS (Limestone)	
Relative Hardness	N-Value *
Soft	Less than 50
Hard	Greater than 50

* Using Automatic Hammer



Unified Soil Classification System (USCS) (from ASTM D 2487)

Major Divisions			Group Symbol	Typical Names	
Coarse-Grained Soils More than 50% retained on the 0.075 mm (No. 200) sieve	Gravels 50% or more of coarse fraction retained on the 4.75 mm (No. 4) sieve	Clean Gravels	GW	Well-graded gravels and gravel-sand mixtures, little or no fines	
			GP	Poorly graded gravels and gravel-sand mixtures, little or no fines	
		Gravels with Fines	GM	Silty gravels, gravel-sand-silt mixtures	
			GC	Clayey gravels, gravel-sand-clay mixtures	
	Sands 50% or more of coarse fraction passes the 4.75 mm (No. 4) sieve	Clean Sands	SW	Well-graded sands and gravelly sands, little or no fines	
			SP	Poorly graded sands and gravelly sands, little or no fines	
		Sands with Fines	SM	Silty sands, sand-silt mixtures	
			SC	Clayey sands, sand-clay mixtures	
			Silts and Clays Liquid Limit 50% or less	ML	Inorganic silts, very fine sands, rock flour, silty or clayey fine sands
				CL	Inorganic clays of low to medium plasticity, gravelly/sandy/silty/lean clays
OL	Organic silts and organic silty clays of low plasticity				
Silts and Clays Liquid Limit greater than 50%	MH	Inorganic silts, micaceous or diatomaceous fine sands or silts, elastic silts			
	CH	Inorganic clays of high plasticity, fat clays			
	OH	Organic clays of medium to high plasticity			
Highly Organic Soils			PT	Peat, muck, and other highly organic soils	

Prefix: G = Gravel, S = Sand, M = Silt, C = Clay, O = Organic

Suffix: W = Well Graded, P = Poorly Graded, M = Silty, L = Clay, LL < 50%, H = Clay, LL > 50%

Appendix B

TABLE 1
Summary of Laboratory Index Tests for Mast Arm Structures
St. Johns County Signal Rebuilds - US Highway 1 & Lewis Point Road
St. Johns County, Florida
MAE Project No.: 0013-0004B

Boring No.	Depth ⁽²⁾ (ft)	Gradation Test, % Passing						Natural Moisture Content, %	Organic Content (%)	Liquid Limit	Plastic Limit	Plasticity Index	USCS Classification
		No. 10	No. 20	No. 40	No. 60	No. 100	No. 200						
B-1	2 - 4	---	---	---	---	---	1.4	14	---	---	---	---	SP
B-1	4 - 6	---	---	---	---	---	2.2	31	---	---	---	---	SP
B-1	23.5 - 25	---	---	---	---	---	1.9	28	---	---	---	---	SP
B-2	6 - 8	---	---	---	---	---	1.1	27	---	---	---	---	SP
B-2	13.5 - 15	---	---	---	---	---	7.5	26	---	---	---	---	SP-SM
B-2	23.5 - 25	---	---	---	---	---	3.5	31	---	---	---	---	SP

(1) Station and Offset were measured from the provided plans and should be considered approximate
(2) Feet below the existing ground surface.

TABLE 2

**Summary of Corrosion Series Test Results for Mast Arm Structures
St. Johns County Signal Rebuilds - US Highway 1 & Lewis Point Road
St. Johns County, Florida
MAE Project No.: 0013-0004B**

Boring No.	Approximate Test Depth ⁽¹⁾ (ft)	Soil Classification	pH	Resistivity (ohm-cm)	Chlorides (ppm)	Sulfates (ppm)	Environmental Classification	
							Concrete Substructure	Steel Substructure
B-2	2 - 3	SP	8.3	26,000	15	6	Slightly Aggressive	Slightly Aggressive

(1) Feet below existing ground surface.

LABORATORY TEST PROCEDURES

Percent Fines Content

The percent fines or material passing the No. 200 mesh sieve of the sample tested was determined in general accordance with the latest revision of ASTM D 1140. The percent fines are the soil particles in the silt and clay size range.

Natural Moisture Content

The water content of the tested sample was determined in general accordance with the latest revision of ASTM D 2216. The water content is defined as the ratio of "pore" or "free" water in a given mass of material to the mass of solid material particles.

Appendix C

TABLE 3

Soil Design Parameters for Mast Arm Structures

St. Johns County Signal Rebuilds - US Highway 1 & Lewis Point Road

St. Johns County, Florida

MAE Project No. 0013-0004B

Structures - Boring No. B-1						
Soil Type	Typical Depth (ft)		Average N-Value	Effective Unit Weight (pcf) ¹	Friction Angle, ϕ (Degrees)	Cohesion (psf)
	From	To				
SP	0	4	20	55	32	0
SP	4	6	3	47	28	0
SP	6	13.5	20	55	32	0
SP-SM	13.5	23.5	50	65	36	0
SP	23.5	25	19	55	32	0
Structures - Boring No. B-2						
Soil Type	Typical Depth (ft)		Average N-Value	Effective Unit Weight (pcf) ¹	Friction Angle, ϕ (Degrees)	Cohesion (psf)
	From	To				
SP	0	4	20	55	32	0
SP	4	6	8	51	30	0
SP	6	13.5	16	55	32	0
SP-SM	13.5	23.5	50	65	36	0
SP	23.5	25	21	55	32	0

Notes:

1. The groundwater level was assumed at the ground surface for design purposes.

BID NO: 21-101

EXHIBIT B

SIGNALIZATION PLANS

PERMIT PLANS

US 1 (SR 5) AT LEWIS POINT ROAD/
ST. AUGUSTINE SOUTH DRIVE
ST. JOHNS COUNTY, FLORIDA (SECTION 78010)

INTERSECTION NUMBER 78M117

SIGNALIZATION PLANS

INDEX OF SIGNALIZATION PLANS

SHEET NO.	SHEET DESCRIPTION
T-1	KEY SHEET
T-2	SIGNATURE SHEET
T-3	TABULATION OF QUANTITIES
T-4 TO T-5	GENERAL NOTES
T-6 TO T-7	SIGNALIZATION PLAN
T-8	MISCELLANEOUS DETAILS
T-9	LIGHTING PLAN
T-10	LIGHTING SPECIAL DETAILS
T-11	STANDARD MAST ARM TABULATION
T-12	STANDARD MAST ARM ASSEMBLIES DATA TABLE
T-13	SPECIAL MAST ARM ASSEMBLIES DATA TABLES
T-14	UTILITY LOCATION PLAN
T-15 TO T-16	GUIDE SIGN WORKSHEET
T-17	REPORT OF CORE BORINGS MAST ARM STRUCTURES

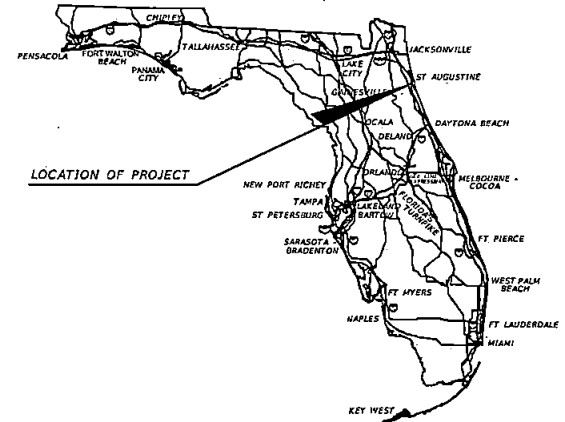

LOCATION OF PROJECT
US 1 (SR 5) MP 13.981

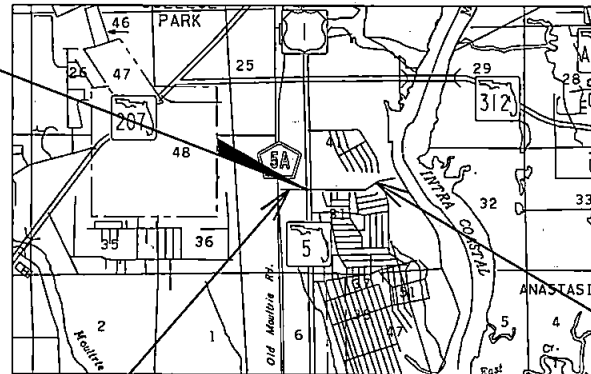

ST. AUGUSTINE SOUTH DRIVE

LEWIS POINT ROAD

SIGNALIZATION SHOP DRAWINGS
TO BE SUBMITTED TO:
KIMLEY-HORN AND ASSOCIATES, INC.
MICHELLE B. MECCA, P.E.
12740 GRAN BAY PARKWAY WEST, SUITE 2350
JACKSONVILLE, FLORIDA 32258

PLANS PREPARED BY:

Kimley»Horn

12740 GRAN BAY PARKWAY WEST, SUITE 2350
JACKSONVILLE, FLORIDA 32258
TEL: (904) 828-3900

NOTE: THE SCALE OF THESE PLANS MAY
HAVE CHANGED DUE TO REPRODUCTION.

FINAL PLANS
MAY 2021

SIGNALIZATION PLANS
ENGINEER OF RECORD: MICHELLE B. MECCA, P.E.

P.E. NO.: 55059

SHEET
NO.

T-1

GOVERNING STANDARD PLANS:
Florida Department of Transportation, FY2018-19 Standard Plans for Road and Bridge Construction and applicable Interim Revisions (IRs).
Standard Plans for Road Construction, and associated IRs are available at the following website: <http://www.fdot.gov/design/standardplans>

GOVERNING STANDARD SPECIFICATIONS:
Florida Department of Transportation, July 2018 Standard Specifications for Road and Bridge Construction
Available at the following website:
<http://www.fdot.gov/programmanagement/implemented/SpecBooks>

REVISIONS:

THE OFFICIAL RECORD OF THIS SHEET IS THE ELECTRONIC FILE DIGITALLY SIGNED AND SEALED UNDER RULE 61G15-73.004, F.A.C.

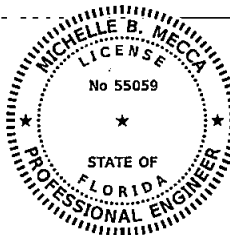

THIS ITEM HAS BEEN DIGITALLY SIGNED AND SEALED BY:

Digitally signed by Michelle B Mecca
Date: 2021.05.28 08:39:31 -04'00'

ON THE DATE ADJACENT TO THE SEAL

PRINTED COPIES OF THIS DOCUMENT ARE NOT CONSIDERED SIGNED AND SEALED AND THE SIGNATURE MUST BE VERIFIED ON ANY ELECTRONIC COPIES.

KIMLEY-HORN AND ASSOCIATES, INC.
12740 GRAN BAY PARKWAY WEST, SUITE 2350
JACKSONVILLE, FLORIDA 32258
PHONE (904) 828-3900
CERTIFICATE OF AUTHORIZATION NO. 696
MICHELLE B. MECCA, P.E. NO. 55059

THE ABOVE NAMED PROFESSIONAL ENGINEER SHALL BE RESPONSIBLE FOR THE FOLLOWING SHEETS IN ACCORDANCE WITH RULE 61G15-23.004, F.A.C.

SHEET NO. SHEET DESCRIPTION

T-1 KEY SHEET
T-2 SIGNATURE SHEET
T-3 TABULATION OF QUANTITIES
T-4 TO T-5 GENERAL NOTES
T-6 TO T-7 SIGNALIZATION PLAN
T-8 MISCELLANEOUS DETAILS
T-11 STANDARD MAST ARM TABULATION
T-14 UTILITY LOCATION PLAN
T-15 TO T-16 GUIDE SIGN WORKSHEET

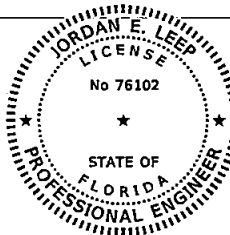

THIS ITEM HAS BEEN DIGITALLY SIGNED AND SEALED BY:

Jordan E Leep 2021.05.27
16:14:11 -04'00'

ON THE DATE ADJACENT TO THE SEAL

PRINTED COPIES OF THIS DOCUMENT ARE NOT CONSIDERED SIGNED AND SEALED AND THE SIGNATURE MUST BE VERIFIED ON ANY ELECTRONIC COPIES.

KIMLEY-HORN AND ASSOCIATES, INC.
1777 MAIN STREET, SUITE 200
SARASOTA, FLORIDA 34236
PHONE (941) 487-7364
CERTIFICATE OF AUTHORIZATION NO. 696
JORDAN E. LEEP, P.E. NO. 76102

THE ABOVE NAMED PROFESSIONAL ENGINEER SHALL BE RESPONSIBLE FOR THE FOLLOWING SHEETS IN ACCORDANCE WITH RULE 61G15-23.004, F.A.C.

SHEET NO. SHEET DESCRIPTION

T-2 SIGNATURE SHEET
T-9 LIGHTING PLAN
T-10 LIGHTING SPECIAL DETAILS

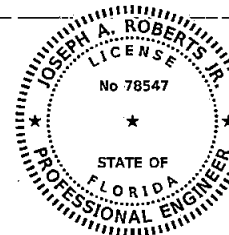

THIS ITEM HAS BEEN DIGITALLY SIGNED AND SEALED BY:

Digitally signed by Joseph A Roberts
Date: 2021.05.27 16:18:31 -04'00'

ON THE DATE ADJACENT TO THE SEAL

PRINTED COPIES OF THIS DOCUMENT ARE NOT CONSIDERED SIGNED AND SEALED AND THE SIGNATURE MUST BE VERIFIED ON ANY ELECTRONIC COPIES.

KIMLEY-HORN AND ASSOCIATES, INC.
189 SOUTH GRANGE AVENUE, SUITE 1000
ORLANDO, FLORIDA 32801
PHONE (407) 898-1511
CERTIFICATE OF AUTHORIZATION NO. 696
JOSEPH A. ROBERTS JR., P.E. NO. 78547

THE ABOVE NAMED PROFESSIONAL ENGINEER SHALL BE RESPONSIBLE FOR THE FOLLOWING SHEETS IN ACCORDANCE WITH RULE 61G15-23.004, F.A.C.

SHEET NO. SHEET DESCRIPTION

T-2 SIGNATURE SHEET
T-12 STANDARD MAST ARM ASSEMBLIES DATA TABLE
T-13 SPECIAL MAST ARM ASSEMBLIES DATA TABLES

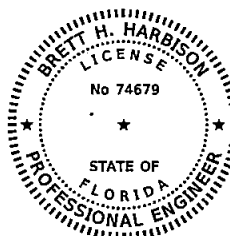

THIS ITEM HAS BEEN DIGITALLY SIGNED AND SEALED BY:

Digitally signed by Brett Harbison
Date: 2021.05.27 18:34:03 -04'00'

ON THE DATE ADJACENT TO THE SEAL

PRINTED COPIES OF THIS DOCUMENT ARE NOT CONSIDERED SIGNED AND SEALED AND THE SIGNATURE MUST BE VERIFIED ON ANY ELECTRONIC COPIES.

MESKEL & ASSOCIATES ENGINEERING, LLC
8936 WESTERN WAY, SUITE 12
JACKSONVILLE, FLORIDA 32256
PHONE (904) 519-6990
CERTIFICATE OF AUTHORIZATION NO. 28142
BRETT H. HARBISON, P.E. NO. 74679

THE ABOVE NAMED PROFESSIONAL ENGINEER SHALL BE RESPONSIBLE FOR THE FOLLOWING SHEETS IN ACCORDANCE WITH RULE 61G15-23.004, F.A.C.

SHEET NO. SHEET DESCRIPTION

T-2 SIGNATURE SHEET
T-17 REPORT OF CORE BORINGS MAST ARM STRUCTURES

REVISIONS			
DATE	DESCRIPTION	DATE	DESCRIPTION

KIMLEY-HORN AND ASSOCIATES, INC.
CERTIFICATE OF AUTHORIZATION NO. 696
MICHELLE B. MECCA, P.E.
P.E. LICENSE NO. 55059
12740 GRAN BAY PARKWAY WEST, SUITE 2350
JACKSONVILLE, FLORIDA 32258

ST. JOHNS COUNTY

ROAD	COUNTY	PROJECT
US 1	ST. JOHNS	LEWIS POINT RD/ ST. AUGUSTINE S DR

SIGNATURE SHEET

SHEET NO.

T-2

TABULATION OF QUANTITIES

PAY ITEM NO.	DESCRIPTION	UNIT	SHEET NUMBERS												TOTAL THIS SHEET		GRAND TOTAL	
			T-6		T-7		T-9											
			PLAN	FINAL	PLAN	FINAL	PLAN	FINAL	PLAN	FINAL	PLAN	FINAL	PLAN	FINAL	PLAN	FINAL	PLAN	FINAL
101-1	MOBILIZATION	LS	1														1	
102-1	MAINTENANCE OF TRAFFIC	LS	1														1	
630-2-11	CONDUIT (F&I) (OPEN TRENCH)	LF	195				50										245	
630-2-12	CONDUIT (F&I) (DIRECTIONAL BORE)	LF	430				280										710	
632-7-1	SIGNAL CABLE (F&I) (NEW OR RECONSTRUCTED INTERSECTION)	PI	1														1	
632-7-6	SIGNAL CABLE (REMOVE-INTERSECTION)	PI	1														1	
633-2-32	FIBER OPTIC CONNECTION (INSTALL) (TERMINATION)	EA	12														12	
633-3-14	FIBER OPTIC CONNECTION HARDWARE (F&I) (BUFFER TUBE FAN OUT KIT)	EA	1														1	
633-3-16	FIBER OPTIC CONNECTION HARDWARE (F&I) (PATCH PANEL-FIELD TERMINATED)	EA	1														1	
635-2-11	PULL & SPLICE BOX (F&I) (13"x24" COVER SIZE)	EA	13			6											19	
635-2-12	PULL & SPLICE BOX (F&I) (24"x36" COVER SIZE)	EA	1														1	
639-1-122	ELECTRICAL POWER SERVICE (F&I) (UNDERGROUND) (PURCHASED)	AS	1														1	
639-2-1	ELECTRICAL SERVICE WIRE (F&I)	LF	130														130	
641-2-12	PRESTRESSED CONCRETE POLE (F&I) (TYPE P-11 SERVICE POLE)	EA	1														1	
641-2-60	PRESTRESSED CONCRETE POLE (COMPLETE POLE REMOVAL-PEDESTAL/SERVICE POLE)	EA	1														1	
641-2-70	PRESTRESSED CONCRETE POLE (SHALLOW POLE REMOVAL-POLE 30' AND GREATER)	EA	4														4	
646-1-11	ALUMINUM SIGNALS POLE (F&I) (PEDESTAL)	EA	7														7	
649-21-10	STEEL MAST ARM ASSEMBLY (F&I) (SINGLE ARM 60')	EA	1														1	
649-21-15	STEEL MAST ARM ASSEMBLY (F&I) (SINGLE ARM 70')	EA	2														2	
649-21-21	STEEL MAST ARM ASSEMBLY (F&I) (SINGLE ARM 78')	EA	1														1	
650-1-14	VEHICULAR TRAFFIC SIGNAL (F&I-ALUMINUM) (3 SECTION) (1 WAY)	AS	9														9	
650-1-16	VEHICULAR TRAFFIC SIGNAL (F&I-ALUMINUM) (4 SECTION) (1 WAY)	AS	4														4	
653-1-11	PEDESTRIAN SIGNAL (F&I LED COUNTDOWN) (1 WAY)	AS	6														6	
653-1-12	PEDESTRIAN SIGNAL (F&I LED COUNTDOWN) (2 WAYS)	AS	1														1	
660-4-11	VEHICLE DETECTION SYSTEM-VIDEO (F&I) (CABINET EQUIPMENT)	EA	1														1	
660-4-12	VEHICLE DETECTION SYSTEM-VIDEO (F&I) (ABOVE GROUND EQUIPMENT)	EA	4														4	
665-1-11	PEDESTRIAN DETECTOR (F&I) (STANDARD)	EA	8														8	
670-5-111	TRAFFIC CONTROLLER ASSEMBLY (F&I) (NEMA) (1 PRE-EMPTION PLAN)	AS	1														1	
670-5-600	TRAFFIC CONTROLLER ASSEMBLY (REMOVE CONTROLLER AND CABINET)	AS	1														1	
682-1-133	ITS CCTV CAMERA (F&I) (DOME PTZ ENCLOSURE, NON-PRESSURIZED) (1P, HIGH DEFINITION)	EA	1														1	
684-1-1	MANAGED FIELD ETHERNET SWITCH (F&I)	EA	1														1	
684-6-11	WIRELESS COMMUNICATION DEVICE (F&I) (ETHERNET ACCESS POINT)	EA	2														2	
685-1-11	UNINTERRUPTIBLE POWER SUPPLY (F&I) (LINE INTERACTIVE)	EA	1														1	
700-1-11	SINGLE POST SIGN (F&I GROUND MOUNT) (UP TO 12 SF)	AS			1												1	
700-3-201	SIGN PANEL (F&I OVERHEAD MOUNT) (UP TO 12 SF)	EA	7														7	
700-5-21	INTERNALLY ILLUMINATED SIGN (F&I OVERHEAD MOUNT) (UP TO 12 SF)	EA	2														2	
700-5-22	INTERNALLY ILLUMINATED SIGN (F&I OVERHEAD MOUNT) (12 TO 18 SF)	EA	2														2	
711-11-160	THERMOPLASTIC PAVEMENT MARKINGS (STANDARD) (WHITE) (MESSAGE OR SYMBOL)	EA			2												2	
711-11-170	THERMOPLASTIC PAVEMENT MARKINGS (STANDARD) (WHITE) (ARROW)	EA			1												1	
711-14-123	THERMOPLASTIC PAVEMENT MARKINGS (PREFORMED) (WHITE) (SOLID) (12" FOR CROSSWALK)	LF			799												799	
711-14-125	THERMOPLASTIC PAVEMENT MARKINGS (PREFORMED) (WHITE) (SOLID) (24" FOR CROSSWALK)	LF			684												684	
711-17	THERMOPLASTIC (REMOVE EXISTING THERMOPLASTIC PAVEMENT MARKINGS)	SF			800												800	
715-1-12	LIGHTING CONDUCTORS (F&I) (INSULATED) (NO. 8-6)	LF					2982										2982	
715-4-13	LIGHT POLE COMPLETE (F&I STANDARD POLE STANDARD FOUNDATION) (40' MOUNTING HEIGHT)	EA					3										3	
715-4-31	LIGHT POLE COMPLETE (F&I UTILITY CONFLICT POLE) (INDEX 17515/715-002 FOUNDATION) (30' MOUNTING HEIGHT)	EA					1										1	
715-4-70	LIGHT POLE COMPLETE (REMOVE POLE AND FOUNDATION)	EA					2										2	
715-5-32	LUMINAIRE & BRACKET ARM (F&I NEW LUMINAIRE AND ARM ON NEW/EXISTING POLE) (GALVANIZED STEEL)	EA					4										4	
715-500-1	POLE CABLE DISTRIBUTION SYSTEM (F&I) (CONVENTIONAL)	EA					4										4	

REVISIONS				KIMLEY-HORN AND ASSOCIATES, INC. CERTIFICATE OF AUTHORIZATION NO. 696 MICHELLE B. MCGA, P.E. P.E. LICENSE NO. 55059 12740 GRAN BAY PARKWAY WEST, SUITE 2350 JACKSONVILLE, FLORIDA 32258	ST. JOHNS COUNTY			TABULATION OF QUANTITIES	SHEET NO. T-3
DATE	DESCRIPTION	DATE	DESCRIPTION		ROAD	COUNTY	PROJECT		
					US 1	ST. JOHNS	LEWIS POINT RD/ ST. AUGUSTINE S DR		

THE OFFICIAL RECORD OF THIS SHEET IS THE ELECTRONIC FILE DIGITALLY SIGNED AND SEALED UNDER RULE 61G15-23.004, F.A.C.

GENERAL NOTES

1. ST. JOHNS COUNTY SHALL BE INFORMED ANY TIME THE CONTRACTOR IS ON THE JOB SITE PERFORMING CONSTRUCTION SHOULD ST. JOHNS COUNTY WISH TO HAVE AN INSPECTOR ON THE SITE. CONTACT TRAFFIC OPERATIONS AT (904) 209-0170.
2. THE CONTRACTOR SHALL NOTIFY ST. JOHNS COUNTY TRAFFIC OPERATIONS AT LEAST 24 HOURS IN ADVANCE OF INSTALLING GROUND RODS, INSTALLING UNDERGROUND CONDUIT, SETTING POLES, INSTALLING SIGNAL HEAD ASSEMBLIES, OR CUTTING LOOPS.
3. NO POLYCARBONATE HOUSING OR MOUNTING HARDWARE SHALL BE PERMITTED.
4. ALL SIGNAL HEADS SHALL BE BLACK ALUMINUM.
5. AT THE TIME OF FINAL PROJECT INSPECTION, THE CONTRACTOR SHALL FURNISH TWO COMPLETE SETS OF SIGNED AND SEALED "AS-BUILT" PLANS AND COMPLETE DOCUMENTATION OF ANY EQUIPMENT AND OR HARDWARE USED FOR CONSTRUCTION.
6. ALL CONDUIT SHALL BE 2-INCH. MINIMUM, EXCEPT ELECTRICAL POWER SERVICE DUCT.
7. THE CONTRACTOR SHALL VERIFY COLOR CODES FOR SIGNAL CABLE WITH ST. JOHNS COUNTY TRAFFIC OPERATIONS PRIOR TO ORDERING CABLE.
8. ST. JOHNS COUNTY RETAINS THE RIGHT TO EITHER ACCEPT OR REFUSE REMOVED EQUIPMENT. IF ST. JOHNS COUNTY ELECTS TO REFUSE REMOVED EQUIPMENT, THE CONTRACTOR WILL BE RESPONSIBLE FOR ALL WORK AND COSTS ASSOCIATED WITH THE REMOVAL AND DISPOSAL OF EQUIPMENT. ALL REMOVED EQUIPMENT THAT IS BEING TURNED OVER TO ST. JOHNS COUNTY SHALL BE DELIVERED TO A DESIGNATED LOCATION SET BY ST. JOHNS COUNTY.
9. ONE SPARE CONDUIT SHALL BE STUBBED AND CAPPED IN EACH OF THE PULL BOXES THAT HAS CONDUIT TO THE CABINET.
10. EXISTING SIGNALIZATION SHALL REMAIN IN PLACE TO THE EXTENT POSSIBLE AND SHALL BE USED FOR MAINTENANCE OF TRAFFIC, AS REQUIRED. ANY MAINTENANCE OF THE EXISTING SIGNALS (UNTIL REMOVED) SHALL REMAIN THE RESPONSIBILITY OF THE CONTRACTOR.
11. LANE CLOSURES WILL NOT BE PERMITTED ON WEEKENDS OR HOLIDAYS, NOR WILL THEY BE PERMITTED DURING THE HOURS OF 7:00AM TO 11:00PM. ST. JOHNS COUNTY AND/OR FDOT TRAFFIC OPERATIONS MAY ADJUST THESE TIMES TO REFLECT ACTUAL FIELD CONDITIONS.
12. WHEN A LANE CLOSURE IS USED AN OFF-DUTY LAW ENFORCEMENT OFFICER SHALL DIRECT TRAFFIC. AT THE CONTRACTOR'S EXPENSE, OFF-DUTY LAW ENFORCEMENT OFFICERS CAN BE OBTAINED FROM THE OFFICE OF THE ST. JOHNS COUNTY SHERIFF BY CONTACTING COMMUNICATIONS AT (904) 810-6671.
13. TWO MANUAL PUSHBUTTON CORDS, TWO KEYS FOR THE CABINET AND TWO KEYS FOR THE POLICE PANEL DOOR SHALL BE FURNISHED.
14. UNLESS SPECIFIED OTHERWISE, ALL PULL BOX COVERS TO FURNISHED AND INSTALLED SHALL BE NON-METALLIC AND SHALL INCLUDE THE RECESSED LOGO "TRAFFIC SIGNALS". ALL FIBER OPTIC PULL BOXES SHALL BE OVERSIZED TO: 3 FOOT BY 2.5 FOOT BY 2 FOOT DEEP.
15. DETECTION, SIGNAL CABLE, INTERCONNECT, AND ELECTRICAL SERVICE WIRE SHALL BE RUN IN SEPARATE CONDUIT AND PULL BOXES.
16. THE CONTRACTOR SHALL MAINTAIN THE ACTUATED OPERATION OF THE SIGNALIZED INTERSECTION THROUGHOUT THE LIFE OF THE CONTRACT. PLANNED DETECTION DISRUPTIONS ARE NOT ALLOWED. ANY UNPLANNED DISRUPTION TO THE VEHICULAR DETECTION SYSTEM AT SIGNALIZED INTERSECTIONS SHALL BE RE-ACTUATED WITHIN 24 HOURS. THIS WILL BE AT THE CONTRACTOR EXPENSE.
17. ST. JOHNS COUNTY TRAFFIC OPERATIONS WILL APPROVE ANY POWER SERVICE CONNECTIONS PRIOR TO INSTALLATION AND CONNECTION. IF A SERVICE PROCESSING FEE IS REQUIRED THE FEE SHALL BE INCLUDED AS PART OF PAYMENT FOR ELECTRICAL POWER SERVICE ASSEMBLY BY THE CONTRACTOR AND SHALL BE RESPONSIBLE FOR THE BALANCE OF THE FEE.
18. IF A POWER METER IS REQUIRED THE METER BASE SHALL BE INSTALLED PER FDOT STANDARD PLANS INDEX 639-002 FIGURE B OR FIGURE D AND MEET THE FDOT STANDARD SPECIFICATIONS FOR ROAD AND BRIDGE CONSTRUCTION 639 NOT ATTACHED TO THE SIGNAL POLES OR CABINET. THE CONTRACTOR SHALL ALSO USE AND INSTALL ANY EQUIPMENT THAT MEETS THE LOCAL UTILITIES REQUIREMENTS.
19. ALL FIELD WIRING SHALL BE NEATLY BUNDLED AND CLEARLY IDENTIFIED WITH PERMANENTLY LEGIBLE, WEATHERPROOF TAGS THAT ARE SECURELY ATTACHED TO EACH CABLE. THE TAGGING SYSTEM PROPOSED SHALL BE SUBMITTED FOR APPROVAL BY ST. JOHNS COUNTY TRAFFIC OPERATIONS.
20. ANY EQUIPMENT USED FOR CONSTRUCTION SHALL BE SUBMITTED TO ST. JOHNS COUNTY TRAFFIC OPERATIONS AND THE ENGINEER OF RECORD FOR APPROVAL PRIOR TO ORDERING.
21. THE CONTRACTOR SHALL BE RESPONSIBLE FOR HAND EXCAVATING TO A DEPTH OF 5 FEET EACH POLE LOCATION TO EXPOSE EXISTING UNDERGROUND UTILITIES AND FOR COORDINATING WITH ALL UTILITY COMPANIES PRIOR TO ORDERING THE SHOP DRAWING FOR THE MAST ARMS. THE CONTRACTOR SHOULD ANTICIPATE UP TO THREE EXCAVATIONS PER LOCATION THAT MAY BE REQUIRED. THE COST FOR HAND EXCAVATING AND TEMPORARILY BACKFILLING THE PROPOSED FOUNDATION LOCATIONS (PRIOR TO FOUNDATION CONSTRUCTION) SHALL BE INCLUDED IN THE PRICE FOR THE MAST ARMS.
22. THE CONTRACTOR SHALL CONTACT LOCAL UTILITY COMPANIES TO DETERMINE THE LOCATION OF UNDERGROUND UTILITIES.
23. THE CONTRACTOR INSTALLING MAST ARMS SHALL NOT DRILL OR OTHERWISE MODIFY MAST ARM BASES OR MATCHING PLATES IN ORDER TO "MAKE IT FIT" WITHOUT THE ENGINEER OF RECORD, FDOT (IF A STATE ROADWAY), ST. JOHNS COUNTY, AND THE MANUFACTURE'S APPROVAL IN WRITING. EACH RESERVE THE RIGHT TO DENY THE MODIFICATION FOR ANY REASON. IT IS THE CONTRACTOR'S RESPONSIBILITY TO ENSURE THE DRILLED SHAFT FOUNDATION, THE MAST ARM AND THE MAST ARM BASE ARE BUILT CORRECTLY.
24. ALL SIGNAL AND PEDESTRIAN INDICATIONS SHALL HAVE L.E.D. DISPLAYS. PEDESTRIAN INDICATIONS SHALL HAVE A COUNT DOWN TIMER.
25. A GREEN COLORED NO. 6 AWG INSULATED STRANDED COPPER WIRE SHALL BE CONNECTED BETWEEN EACH OF THE INTERSECTION METAL MAST ARM AND PEDESTRIAN POLE GROUND ROD CONNECTION POINTS AND THEN TO THE CONTROLLER GROUND BUS. THIS WIRE SHALL BE PULLED IN THE SAME CONDUIT AS THE SIGNAL CABLE.
26. EACH POLE AND MAST ARM SHALL BE IDENTIFIED WITH A PERMANENT 1-INCH HIGH ENGRAVED OR IMPRESSED MARK WHICH CONTAINS ALL REQUIRED IDENTIFICATION INFORMATION.
27. ONCE THE SIGNAL HEADS ARE INSTALLED, THE CONTRACTOR SHALL BAG EACH HEAD. THE PROPOSED BAGGING MATERIAL SHALL BE DURABLE AND DESIGNED FOR LONG-TERM APPLICATION. NO PLASTIC GARBAGE BAGS OR TAPE SHALL BE USED.
28. THE CONTRACTOR SHALL ENSURE ALL EQUIPMENT INSTALLED IS COMPATIBLE WITH ST. JOHNS COUNTY'S EXISTING EQUIPMENT AND SOFTWARE PER SITE.
29. A NO. 14 AWG INSULATED STRANDED COPPER WIRE SHALL BE PULLED IN THE SAME CONDUIT AS THE FIBER OPTIC CABLE. PULL BOX TO PULL BOX AND NOT INTO THE CABINET.
30. THE TRAFFIC SIGNAL HEADS SHALL BE MOUNTED VERTICAL.
31. THE CONTRACTOR SHALL USE A FLORIDA REGISTERED AND FDOT PREQUALIFIED GEOTECHNICAL ENGINEERING FIRM FOR TESTING AND QA/QC INCLUDING BUT NOT LIMITED TO DRILLED SHAFT INSPECTION WITH CROSS SONIC LOGGING, CONCRETE SLUMP AND TEMPERATURE.
32. THE CONTRACTOR SHALL NOTIFY THE ENGINEER OF QUALITY CONTROL TESTING LOCATIONS AND TIMES AT LEAST ONE BUSINESS DAY PRIOR. THE CONTRACTOR SHALL PROVIDE THE ENGINEER AND FDOT A COPY OF TEST RESULTS AND REPORTS WITHIN ONE BUSINESS DAY OF RECEIPT.
33. THE CONTRACTOR SHALL HAVE A FDOT CERTIFIED TEMPORARY TRAFFIC CONTROL SPECIALIST DURING HOT SETUP, BREAKDOWN AND DAILY MAINTENANCE. THE CONTRACTOR SHALL NOTIFY THE ENGINEER AND FDOT OF ANY REQUIRED LANE CLOSURES AT LEAST ONE WEEK PRIOR.
34. THE CONTRACTOR SHALL PROVIDE A STAGING AREA FOR ALL MATERIALS. NO MATERIALS OR EQUIPMENT SHALL BE STORED WITHIN THE RIGHT-OF-WAY.
35. ALL EXCAVATORS ARE REQUIRED TO CONTACT THE SUNSHINE STATE ONE CALL OF FLORIDA, PHONE NUMBER 1 (800) 432-4770 OR 811 A MINIMUM OF TWO WORKING DAYS (EXCLUDING WEEKENDS) IN ADVANCE OF COMMENCEMENT OF EXCAVATION TO ENSURE FACILITIES ARE LOCATED ACCURATELY.
36. CONDUCT ALL LOCATIONS AND EXCAVATIONS IN ACCORDANCE WITH THE FLORIDA STATUTE 556 OF THE UNDERGROUND FACILITIES DAMAGE PREVENTION & SAFETY ACT AND ALL LOCAL CITY AND COUNTY ORDINANCES THAT MAY APPLY.
37. ALL AREAS OF DISTURBED EXISTING OR PROPOSED CITY, COUNTY, OR STATE RIGHT-OF-WAY SHALL BE SOODED.
38. THE ENGINEER OF RECORD SHALL BE GIVEN FORTY-EIGHT HOURS (48 HOURS) NOTICE OF ALL MEETINGS AND OR TESTING MEASURES RELATED TO SAID PROJECT.
39. EXISTING UTILITIES SHOWN ARE LOCATED ACCORDING TO THE INFORMATION AVAILABLE TO THE ENGINEER AT THE TIME AND HAVE NOT BEEN INDEPENDENTLY VERIFIED BY THE OWNER OR ENGINEER. GUARANTEE IS NOT MADE THAT ALL EXISTING UNDERGROUND UTILITIES ARE SHOWN OR THAT THE LOCATION OF THOSE SHOWN ARE ENTIRELY ACCURATE. FINDING THE ACTUAL LOCATION OF ANY EXISTING UTILITIES IS THE CONTRACTOR'S RESPONSIBILITY AND SHALL BE DONE BEFORE HE/SHE COMMENCES ANY WORK IN THE VICINITY. FURTHERMORE, THE CONTRACTOR SHALL BE FULLY RESPONSIBLE FOR ANY AND ALL DAMAGES DUE TO THE CONTRACTOR'S FAILURE TO EXACTLY LOCATE AND PRESERVE ANY AND ALL UNDERGROUND UTILITIES. THE OWNER OR ENGINEER WILL ASSUME NO LIABILITY FOR ANY DAMAGES SUSTAINED OR COST INCURRED BECAUSE OF THE OPERATIONS IN THE VICINITY OF EXISTING UTILITIES OR STRUCTURES, NOR FOR TEMPORARY BRACING AND SHORING OF SAME.
40. THE CONTRACTOR IS RESPONSIBLE FOR ANY DAMAGE TO EXISTING UTILITIES, SURVEY MONUMENTS, MARKERS, CORNERS, AND EXISTING FEATURES IN THE AREA. ANY DAMAGE SHALL BE REPLACED/REPAIRED BY THE CONTRACTOR AT NO ADDITIONAL EXPENSE TO THE OWNER.
41. THE CONTRACTOR SHALL BE RESPONSIBLE FOR TRAFFIC SIGNAL HEAD ALIGNMENT AND LOCATION FOR INTERIM NOT AND FINAL INSPECTIONS. ST. JOHNS COUNTY NOR FDOT SHALL BE CHARGED TO ADJUST THE HEADS AS REQUIRED.
42. REMOVAL OF PAVEMENT MARKINGS SHALL NOT SIGNIFICANTLY ALTER THE PAVEMENT TEXTURE.
43. THE CONTRACTOR SHALL HAVE A CERTIFIED IMSA ROADWAY LIGHTING TECHNICIAN AND TRAFFIC SIGNAL CONSTRUCTION TECHNICIAN ON SITE OVERSEEING THE SIGNAL INSTALLATION.
44. THE CONTRACTOR SHALL SCHEDULE AN INSPECTION WITH FDOT AT 90% COMPLETION OF CONSTRUCTION.
45. ALL ASSOCIATED EQUIPMENT SHALL BE COMPATIBLE WITH THE ST. JOHNS COUNTY TRAFFIC MANAGEMENT CENTER'S TRAFFICWARE ATMS.NOW CENTRAL SOFTWARE.
46. THE CONTRACTOR SHALL KEEP ONE CROSSWALK OPEN IN EACH DIRECTION, AT ALL TIMES, IN ORDER TO MAINTAIN PEDESTRIAN ACCESS.
47. PRIOR TO PERFORMING WORK WITHIN THE US 1 (SR 5) RIGHT-OF-WAY, THE CONTRACTOR SHALL NOTIFY FDOT EMPLOYEE CHRISTOPHER POGUE AT (904) 825-5086

THE OFFICIAL RECORD OF THIS SHEET IS THE ELECTRONIC FILE DIGITALLY SIGNED AND SEALED UNDER RULE 61G13-23.004, F.A.C.

REVISIONS		KIMLEY-HORN AND ASSOCIATES, INC.		ST. JOHNS COUNTY			SHEET NO.
DATE	DESCRIPTION	DATE	DESCRIPTION	ROAD	COUNTY	PROJECT	
				US 1	ST. JOHNS	LEWIS POINT RD/ ST. AUGUSTINE S DR	GENERAL NOTES

CERTIFICATE OF AUTHORIZATION NO. 696
 MICHELLE B. MECCA, P.E.
 P.E. LICENSE NO. 85058
 12740 GRAN BAY PARKWAY WEST, SUITE 2350
 JACKSONVILLE, FLORIDA 32258

PAY ITEM NOTES

- PAY ITEM 641-2-70:**
SHALL INCLUDE THE COST TO RESTORE THE DAMAGED SIDEWALK FROM THE REMOVAL OF EXISTING CONCRETE STRAIN POLES.
- PAY ITEMS 660-4-11 AND 660-4-12**
CAMERAS V1 AND V5 SHALL BE GRIDSMA RT SHARTHOUNT KIT W/CAMERA (GS-3-SMK). CAMERAS V2 AND V6 SHALL BE GRIDSMA RT ADVANCED CAMERA FIBER (GS-3-SMA-F). CONTACT CUBIC AT 904-613-9331 TO ARRANGE FOR ORDER AND INSTALLATION.
- PAY ITEM 670-5-111:**
SHALL BE TRAFFICWA RE GROUP WIRED CABINET ASSEMBLY TS-2 SIZE-6 CABINET WITH TRAFFICWA RE GROUP TS-2 TYPE 2 MODEL 981-A1100 CONTROLLER WITH ETHERNET.

THE EXISTING CONCRETE BASE SHALL BE REUSED. THE EXISTING CONDUITS FOR ELECTRIC, 12 MM FIBER OPTIC CABLE, LOOP DETECTION, AND FIRE STATION PREEMPTION SHALL BE RETAINED. THERE IS NO AVAILA BLE SLACK IN THE EXISTING 12 MM FO OR PREEMPTION. THE LOOP DETECTION WILL NOT BE WIRED TO THE NEW CONTROLLER BUT WILL BE LEFT INTACT FOR FUTURE ACCESSIBILITY. NEW CONDUITS FOR SIGNAL CABLE, LIGHTING, AND VIDEO DETECTION SHALL BE DRILLED INTO OPEN SPACE IN EXISTING CONCRETE BASE.
- PAY ITEM 684-1-1:**
SHALL BE IT'S EXPRESS 8040 SWITCH.
- PAY ITEM 684-6-11:**
SHALL BE UBIQUITI NETWORKS NANO STATION M MODEL NSMS.
- PAY ITEM 685-1-11:**
SHALL BE TEMPLE MODEL FXM 2000. SYSTEM SHALL BE INSTALLED AND HOUSED IN A SEPARATE CABINET FROM THE TRAFFIC CONTROLLER CABINET ASSEMBLY.

DIRECTIONAL BORE NOTES

1. WHEN PERFORMING A HORIZONTAL DIRECTIONAL DRILLING (HDD) OPERATION, THE UTILITY/AGENCY OWNER (UAO) SHALL RESTRICT THE BORED DIAMETER TO THE MAXIMUM DIAMETER ALLOWED FOR THE DIAMETER OF THE UTILITY BEING INSTALLED. THE UTILITY DIAMETER IS THE CASING DIAMETER WHEN CASING IS USED. FOR UTILITY DIAMETERS LESS THAN EIGHT (8) INCHES, THE MAXIMUM BORED DIAMETER IS EQUAL TO THE UTILITY DIAMETER PLUS FOUR (4) INCHES. FOR UTILITY DIAMETERS OF EIGHT (8) INCHES TO TWENTY-FOUR (24) INCHES, THE MAXIMUM BORED DIAMETER IS EQUAL TO ONE AND ONE HALF (1.5) TIMES THE UTILITY DIAMETER. FOR UTILITY DIAMETERS GREATER THAN TWENTY-FOUR (24) INCHES, THE MAXIMUM BORED DIAMETER IS EQUAL TO THE UTILITY DIAMETER PLUS ONE (1) FOOT. WHERE A UTILITY HAS RESTRAINED JOINTS THE MAXIMUM BORED DIAMETER SHALL BE THE MANUFACTURER'S RECOMMENDED DIAMETER. ADDITIONALLY, THE UAO SHOULD MAINTAIN A CLEARANCE FROM ANY EXISTING VITRIFIED CLAY SANITARY PIPE LINE OR EXISTING GAS LINES, OF AT LEAST THREE AND ONE HALF (3.5) TIMES THE BORED DIAMETER.
2. WHEN BORING UNDER ROADWAY PAVEMENT, THE UAO SHALL MAINTAIN A BORE DEPTH OF AT LEAST TEN (10) TIMES THE BORED DIAMETER OR 30 INCHES, WHICHEVER IS GREATER, AS MEASURED FROM THE TOP OF PAVEMENT TO THE TOP OF THE BORE. THE UAO MAY REDUCE THIS DEPTH BY DETERMINING THE WATER TABLE ANTICIPATED AT TIME OF INSTALLATION OR A CONFINING LAYER. THE CONFINING LAYER IS A TWO (2) FEET THICK LAYER OF EARTH THAT RESISTS THIRTY (30) BLOWS PER FOOT OF A STANDARD PENETRATION TEST. IF EITHER OF THESE IS DETERMINED, THE BORE DEPTH MAY BE REDUCED TO TWO (2) FEET BELOW THE TOP OF THE CONFINING LAYER TO THE TOP OF THE BORE, OR TWO (2) FEET BELOW THE TOP OF THE WATER TABLE TO THE TOP OF THE BORE. ADDITIONALLY, THE UAO SHOULD MAINTAIN A CLEARANCE FROM ANY EXISTING VITRIFIED CLAY SANITARY PIPE LINE OR EXISTING GAS LINES, OF AT LEAST THREE AND ONE HALF (3.5) TIMES THE BORED DIAMETER.
3. THE UAO SHALL ALSO DO ALL OF THE FOLLOWING:
 - 1) DETERMINE ORIENTATION AND TRACKING OF THE DRILL BIT.
 - 2) UTILIZE RELIEF HOLES AS NECESSARY TO RELIEVE EXCESS PRESSURE DOWN HOLE.
 - 3) PREVENT HEAVING DURING PULL BACK.
 - 4) KEEP THE DRILL PIPE IN THE BORE HOLE UNTIL THE FINAL PRODUCT IS PULLED INTO PLACE.
 - 5) WHEN BORING UNDER ROADWAY PAVEMENT, INSTALL THE PRODUCT INTO A BORE HOLE WITHIN THE SAME DAY THAT THE PRE-BORE IS COMPLETED.

UTILITY NOTES

1. THE LOCATION(S) OF THE UTILITIES SHOWN IN THE PLANS (INCLUDING THOSE DESIGNATED Vv, Vh, AND Vvh) ARE BASED ON LIMITED INVESTIGATION TECHNIQUES AND SHOULD BE CONSIDERED APPROXIMATE ONLY. THE VERIFIED LOCATIONS/ ELEVATIONS APPLY ONLY AT THE POINTS SHOWN. INTERPOLATIONS BETWEEN THESE POINTS HAVE NOT BEEN VERIFIED.
2. ALL FPL OVERHEAD ELECTRICAL FACILITIES TO REMAIN ENERGIZED AND IN PLACE. TABLE A MINIMUM CLEARANCE DISTANCES SPECIFIED IN SUBPART CC OF OSHA RULE 29 CFR PART 1928 (AS THEY PERTAIN TO CRANE/DERRICK OPERATIONS), AND/OR THOSE MINIMUM DISTANCES SPECIFIED IN 29 CFR 1910.332(C)(3) FOR WORK IN PROXIMITY TO POWER LINES NOT COVERED BY SUBPART CC, MUST BE MAINTAINED. THE CONTRACTOR SHALL COORDINATE WITH FPL AND ENGINEER OF RECORD TO CONFIRM MINIMUM CLEARANCE DISTANCES FROM OVERHEAD ELECTRIC FACILITIES.
3. UTILITY AGENCY OWNERS PER DIG TICKET:

FPL ELECTRIC	(800) 468-8243
CENTURYLINK	(352) 303-2430
TECO GAS	(813) 228-1351
AT&T COMM.	(561) 997-0240
ST. JOHNS COUNTY WATER & SEWER	(904) 209-2701
UNITI FIBER	(904) 718-8152

PROJECT CONTROL

STATION	OFFSET	DESCRIPTION	NOTES
737+00.00	60.00' LT	SET MAG. NAIL & DISK LB 6979	
737+00.00	0.00' RT	SET MAG. NAIL & DISK LB 6979	N 2005777.03, E 553869.74
737+00.00	60.00' RT	SET 1/2" IP W/CAP LB6979	
741+00.00	60.00' LT	SET 1/2" IP W/CAP LB6979	
741+00.00	0.00' RT	SET MAG. NAIL & DISK LB 6979	N 2006176.97, E 553862.38
741+00.00	60.00' RT	SET MAG. NAIL & DISK LB 6979	

NOTE: THE DATA IN THIS TABLE HAS BEEN ADDED TO THE PLANS FROM THE ORIGINAL SURVEY PERFORMED BY GEOMATICS CORP. BENCHMARK ELEVATIONS SHOWN ON THE PLANS ARE NORTH AMERICAN VERTICAL DATUM OF 1988 (NAVD 88)

REVISIONS				KIMLEY-HORN AND ASSOCIATES, INC. CERTIFICATE OF AUTHORIZATION NO. 696 MICHELLE B. MECCA, P.E. P.E. LICENSE NO. 55059 12740 GRAN BAY PARKWAY WEST, SUITE 2350 JACKSONVILLE, FLORIDA 32256	ST. JOHNS COUNTY			GENERAL NOTES	SHEET NO. T-5
DATE	DESCRIPTION	DATE	DESCRIPTION		ROAD	COUNTY	PROJECT		
					US 1	ST. JOHNS	LEWIS POINT RD/ ST. AUGUSTINE S DR		

Jack Huisberg

5/27/2021

3:41:52 PM

K:\JAM_IPTV\044692020_US 1 and Lewis Point Road_11R\0000000000\signals\gnntsg01.dgn

SIGNALIZATION NOTES:

- MAJOR STREET IS US 1 (45 MPH). MINOR STREETS ARE LEWIS POINT ROAD (30 MPH) AND ST. AUGUSTINE SOUTH DRIVE (25 MPH).
- FLASHING OPERATION: MOVEMENTS 2 AND 6 YELLOW. MOVEMENTS 1, 3, 4, 5, 7, AND 8 RED.
- S.O.P. 10 WITH CONCURRENT PEDESTRIAN PHASE P2, P4, P6, AND P8.
- P.O.P. FOR FIRE STATION PREEMPTION ON MOVEMENTS 3 AND 8.
- EXISTING CONTROLLER CABINET BASE TO BE REUSED TO ACCOMMODATE EXISTING FIBER AND PREEMPTION CONNECTIONS. CONTRACTOR SHALL PHASE CONSTRUCTION ACCORDINGLY TO MAINTAIN SIGNAL FUNCTIONALITY AT ALL TIMES OR UTILIZE TRAFFIC CONTROL OFFICER.
- CONTRACTOR SHALL FIELD VERIFY MAST ARM LOCATION ELEVATIONS PRIOR TO ORDERING MAST ARMS.
- PRIOR TO INSTALLATION OF MAST ARMS, CONTRACTOR SHALL COORDINATE WITH APPROPRIATE UTILITIES WITH RESPECT TO MAINTAINING MINIMUM CLEARANCE BETWEEN ENERGIZED CONDUCTORS AND POLES.

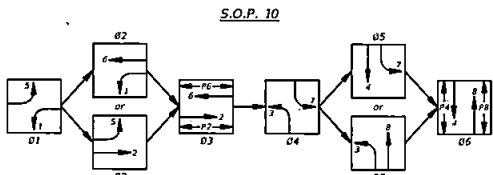

CONTROLLER TIMINGS								
TIMING FUNCTION								
MOVEMENT NUMBER	1	2	3	4	5	6	7	8
MINIMUM GREEN	4	18	4	6	4	18	4	6
EXTENSION	3.0	2.5	3.0	3.0	3.0	2.5	3.0	3.0
MAXIMUM GREEN 1	25	70	20	45	20	70	20	25
MAXIMUM GREEN 2	-	-	-	-	-	-	-	-
YELLOW CLEARANCE	4.8	4.8	3.4	3.7	4.8	4.8	3.7	3.4
ALL RED	2.0	2.0	2.8	2.8	2.0	2.0	2.8	2.8
PEDESTRIAN WALK	-	7	-	7	-	7	-	7
PED. CLEARANCE	-	31	-	30	-	28	-	32
RECALL	-	MIN	-	-	-	MIN	-	-

VIDEO DETECTION ZONES				
DETECTOR	DET. ZONE	SIZE	NO. OF LANES	DELAY TIME (SEC)
V1	ZONE 1	6' x 30'	1	5
	ZONE 4	6' x 30'	1	0
	ZONE 4R	6' x 30'	1	10
V2	ZONE 7	6' x 30'	1	0
	ZONE 2	6' x 6'	3	0
V5	ZONE 3	6' x 30'	1	0
	ZONE 5	6' x 30'	1	5
	ZONE 8	6' x 30'	1	0
	ZONE 8R	6' x 30'	1	10
V6	ZONE 6	6' x 6'	2	0

▨ DENOTES VEHICLE DETECTION ZONE

DELAY TIME IS INITIAL AND MAY REQUIRE FIELD ADJUSTMENT AS DIRECTED BY PROJECT ENGINEER.

PAVEMENT MARKING NOTES:

- REMOVE ALL EXISTING 12" CROSSWALK STRIPES.
- INSTALL NEW 12" EDGE STRIPES FOR HIGH EMPHASIS CROSSWALKS DIRECTLY OVER REMOVED CROSSWALK STRIPES.

PRE-EMPTION TIMINGS	
MINIMUM GREEN BEFORE PRE-EMPTION	5
YELLOW CLEARANCE	4.8
ALL RED CLEARANCE	2.0
MINIMUM DWELL	20
YELLOW CLEARANCE	3.4
ALL RED CLEARANCE	2.8

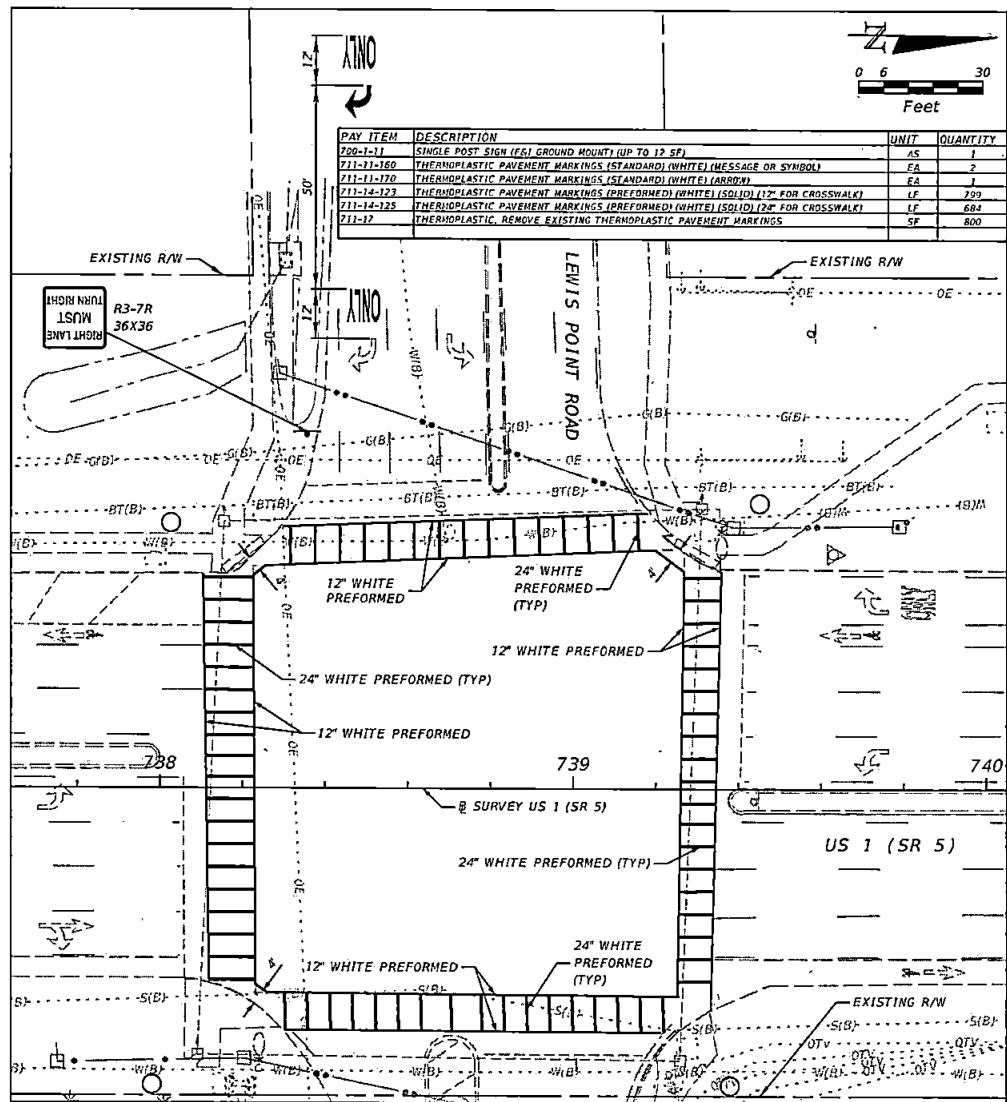

PAY ITEM	DESCRIPTION	UNIT	QUANTITY
Z00-1-11	SINGLE POST SIGN (FS) GROUND MOUNT (UP TO 12 SF)	AS	1
Z11-11-150	THERMOPLASTIC PAVEMENT MARKINGS (STANDARD) (WHITE) (MESSAGE OR SYMBOL)	EA	2
Z11-11-170	THERMOPLASTIC PAVEMENT MARKINGS (STANDARD) (WHITE) (ARROW)	EA	1
Z11-14-123	THERMOPLASTIC PAVEMENT MARKINGS (PREFORMED) (WHITE) (SOLID) (12" FOR CROSSWALK)	LF	750
Z11-14-125	THERMOPLASTIC PAVEMENT MARKINGS (PREFORMED) (WHITE) (SOLID) (12" FOR CROSSWALK)	LF	684
Z11-17	THERMOPLASTIC, REMOVE EXISTING THERMOPLASTIC PAVEMENT MARKINGS	SF	800

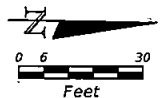

REVISIONS				KIMLEY-HORN AND ASSOCIATES, INC. CERTIFICATE OF AUTHORIZATION NO. 696 MICHELLE B. WECIA, P.E. P.E. LICENSE NO. 63059 12740 GRAN BAY PARKWAY WEST, SUITE 2350 JACKSONVILLE, FLORIDA 32258	ST. JOHNS COUNTY		SIGNALIZATION PLAN	SHEET NO. T-7
DATE	DESCRIPTION	DATE	DESCRIPTION		ROAD	COUNTY		
					US 1	ST. JOHNS	LEWIS POINT RD/ ST. AUGUSTINE S DR	

THE OFFICIAL RECORD OF THIS SHEET IS THE ELECTRONIC FILE DIGITALLY SIGNED AND SEALED UNDER RULE 61G15-23.004, F.A.C.

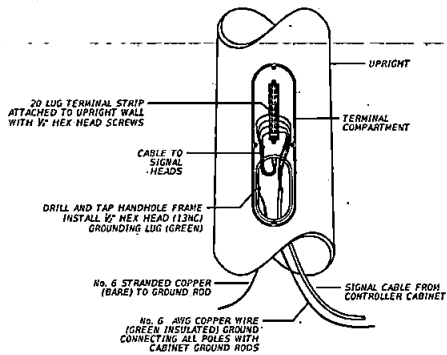

WIRING DETAILS
N.T.S.

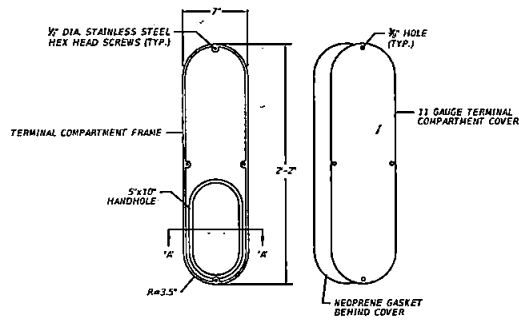

TERMINAL COMPARTMENT FRAME AND COVER DETAIL
N.T.S.

NOTE: HANDHOLE COVER AND COVER CLIPS SHOWN IN INDEX 17745 ARE NOT REQUIRED ON POLES WHERE TERMINAL COMPARTMENT IS SPECIFIED.

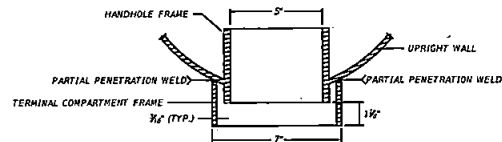

SECTION "A-A"
N.T.S.
MAST ARM DETAILS
N.T.S.

- NOTES:-
1. PED DETECTOR, PED SIGN, AND PED SIGNAL SHALL BE ORIENTATED FACING THE CROSSWALK THEY SERVICE.
 2. WHEN TWO PED SIGNALS ARE MOUNTED ON THE SAME PEDESTAL, THE PED SIGNALS SHALL BE CANTILEVERED AS NEEDED TO MOUNT AT THE SAME HEIGHT.
 3. THE BASE AND POLE SHALL BOTH BE ALUMINUM. THE POLE SHALL HAVE A BRUSHED FINISH.

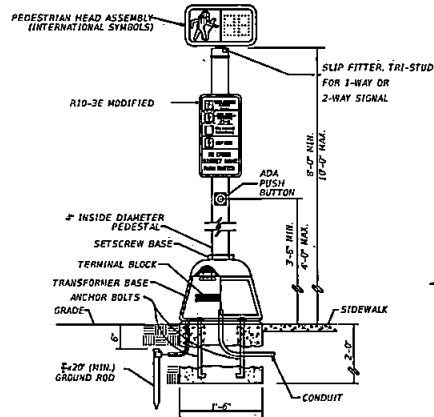

PEDESTRIAN SIGNAL PEDESTAL DETAIL
N.T.S.

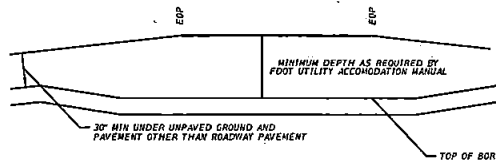

NOTE: DISTANCE BETWEEN EXISTING ROADWAY PAVEMENT AND TOP OF BORE SHALL NOT BE LESS THAN 48 INCHES.

DIRECTIONAL BORE PROFILE

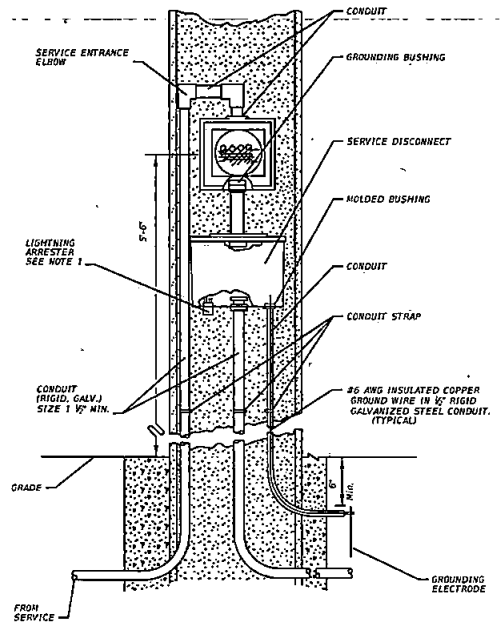

ELECTRIC POWER SERVICE DETAIL: UNDERGROUND FEED (METER USED)
N.T.S.

REVISIONS	
DATE	DESCRIPTION

KIMLEY-HORN AND ASSOCIATES, INC.
CERTIFICATE OF AUTHORIZATION NO. 696
MICHELLE B. HECCA, P.E.
P.E. LICENSE NO. 55059
12740 GRAN BAY PARKWAY WEST, SUITE 2350
JACKSONVILLE, FLORIDA 32258

ST. JOHNS COUNTY		
ROAD	COUNTY	PROJECT
US 1	ST. JOHNS	LEWIS POINT RD / ST. AUGUSTINE S DR

MISCELLANEOUS DETAILS

SHEET NO.
T-8

THE OFFICIAL RECORD OF THIS SHEET IS THE ELECTRONIC FILE DIGITALLY SIGNED AND SEALED UNDER RULE 61G15-23.004, F.A.C.

POLE DATA

POLE NO.	CIRCUIT	STATION	POLE OFFSET	MOUNTING HEIGHT	ARM LENGTH	IES FILE	PAY ITEM
0	EX-C	737+75.00	62.50 RT	40'	15'	ATBL_E_XXXX_R4	715-4-13
S1	SIGNAL	737+98.12	72.37 RT	40'	12'	ATBL_E_XXXX_R4	715-5-32*
S2	SIGNAL	738+02.77	64.59 LT	40'	12'	ATBL_E_XXXX_R4	715-5-32*
31A	EX-A	738+28.50	104.50 LT	30'	15'	ATBL_D_XXXX_R3	715-4-31*
0A	EX-C	739+26.47	91.76 RT	40'	15'	ATBL_E_XXXX_R4	715-4-13
S3	SIGNAL	739+38.04	72.47 RT	40'	12'	ATBL_E_XXXX_R4	715-5-32*
S4	SIGNAL	739+45.20	69.60 LT	40'	12'	ATBL_E_XXXX_R4	715-5-32*
31	EX-A	739+82.50	66.50 LT	40'	15'	ATBL_E_XXXX_R4	715-4-13

* SEE LIGHTING SPECIAL DETAILS SHEET FOR UTILITY CONFLICT POLE DETAILS AND DAVIT ARM DETAILS FOR MAST ARM MOUNTED LUMINAIRES

SUMMARY OF LIGHTING QUANTITIES

PAY ITEM NO.	DESCRIPTION	UNIT	TOTAL THIS SHEET
630-2-11	CONDUIT (F&I) (OPEN TRENCH)	LF	50
630-2-12	CONDUIT (F&I) (DIRECTIONAL BORE)	LF	280
635-2-11	PULL & SPLICE BOX (F&I) [13"x24" COVER SIZE]	EA	6
715-1-12	LIGHTING CONDUCTORS (F&I) (INSULATED) (NO. 8-6)	LF	2982
715-4-13	LIGHT POLE COMPLETE (F&I STD POLE STD FOUNDATION) (40' MH)	EA	3
715-4-31	LIGHT POLE COMPLETE (F&I UTILITY CONFLICT POLE) (30' MH)	EA	1
715-4-70	LIGHT POLE COMPLETE (REMOVE POLE AND FOUNDATION)	EA	2
715-5-32	LUMINAIRE & BRACKET ARM (F&I NEW LUMINAIRE AND ARM ON NEW POLE) (GALV STEEL)	EA	4
715-500-1	POLE CABLE DISTRIBUTION (F&I) (CONVENTIONAL)	EA	4

CONVENTIONAL

LIGHTING DESIGN CRITERIA

AVERAGE INITIAL INTENSITY 3.0 FOOT CANDLES
 UNIFORMITY RATIO AVG./MIN. 4:1 OR LESS
 UNIFORMITY RATIO MAX./MIN. 10:1 OR LESS
 DESIGN WIND SPEED 140 MPH

VERTICAL LIGHTING CRITERIA FOR CROSSWALKS

AVERAGE INITIAL INTENSITY 2.3 FOOT CANDLES*
 *WHERE NEW INTERSECTION PHOTOMETRIC CRITERIA CANNOT BE MET, RETROFIT CRITERIA IS USED AS THE BASIS OF DESIGN

LEGEND

SYMBOL

DESCRIPTION

- MANUFACTURER: AMERICAN ELECTRIC LIGHTING, MODEL: AUTOBAHN, PHOTOMETRIC CURVE: ATBL_D_XXXX_R3 OR ATBL_D_XXXX_R4 (SEE POLE DATA TABLE FOR LOCATIONS) WAS USED AS THE BASIS OF DESIGN. WIRED FOR 480V SINGLE PHASE OPERATION.
- MANUFACTURER: AMERICAN ELECTRIC LIGHTING, MODEL: AUTOBAHN, PHOTOMETRIC CURVE: ATBL_D_XXXX_R4 WAS USED AS THE BASIS OF DESIGN. WIRED FOR 120V SINGLE PHASE OPERATION. LUMINAIRE AND BRACKET ARM MOUNTED ON MAST ARM.
- EXISTING LIGHT POLE TO BE REMOVED
- PROPOSED LOCATION OF 13' X 24' LIGHTING PULL BOX
-

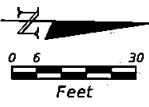
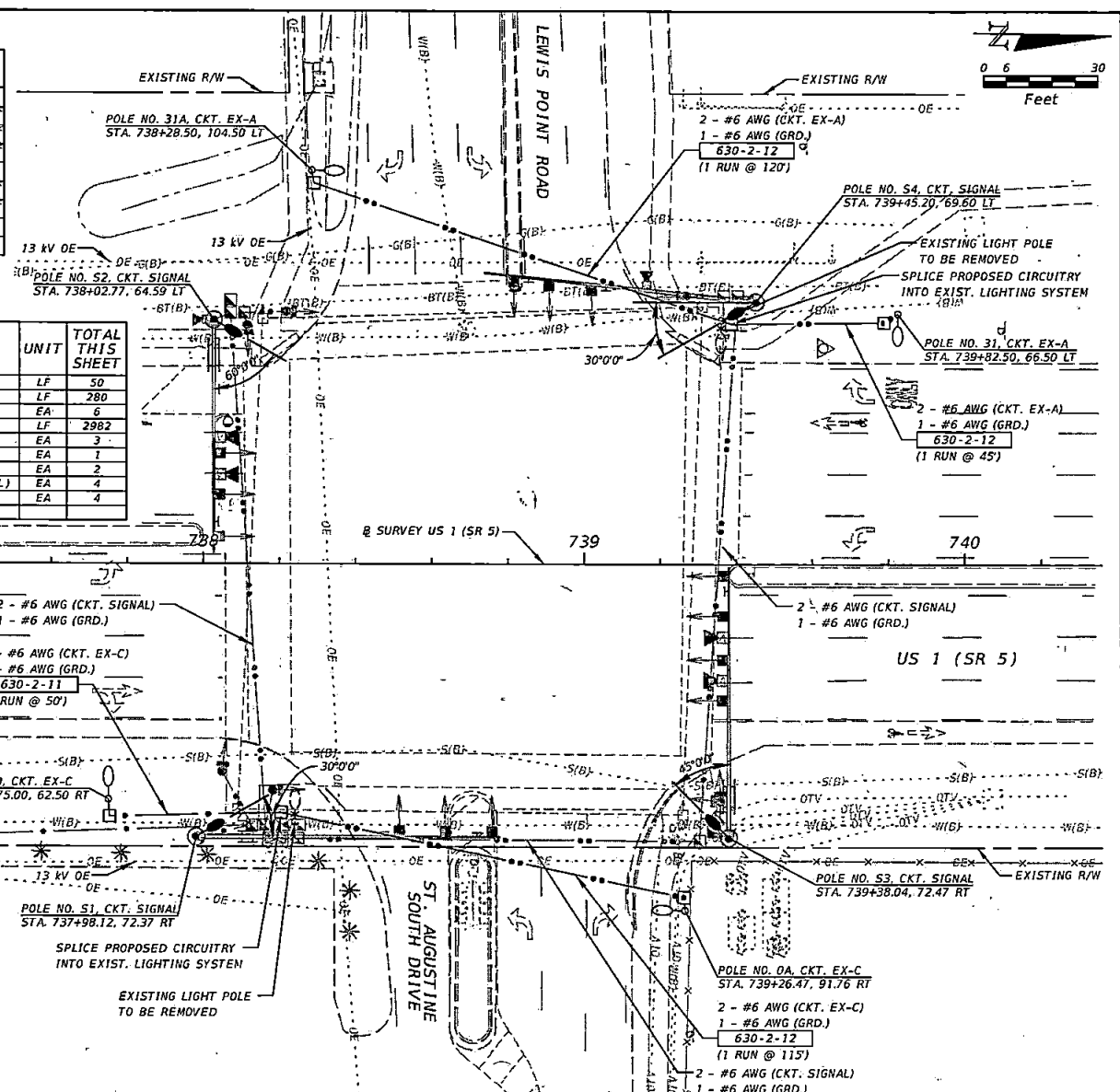

REVISIONS

DATE	DESCRIPTION	DATE	DESCRIPTION

KIMLEY-HORN AND ASSOCIATES, INC.

CERTIFICATE OF AUTHORIZATION NO. 696
 JORDAN E. LEE, P.E.
 P.E. LICENSE NO. 76102
 1777 MAIN STREET, SUITE 200
 SARASOTA, FLORIDA 34236

ST. JOHNS COUNTY

ROAD	COUNTY	PROJECT
US 1	ST. JOHNS	LEWIS POINT RD/ ST. AUGUSTINE S DR

LIGHTING PLAN

SHEET NO.

T-9

THE OFFICIAL RECORD OF THIS SHEET IS THE ELECTRONIC FILE DIGITALLY SIGNED AND SEALED UNDER RULE 61G15-23.004, F.A.C.

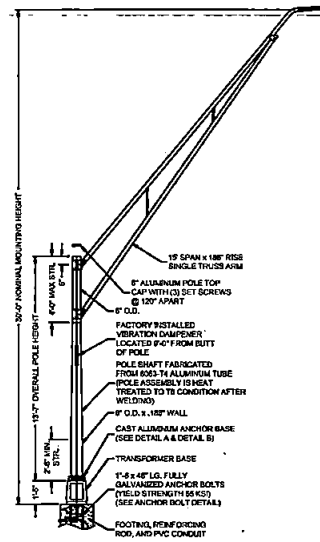

UTILITY CONFLICT POLE ASSEMBLY

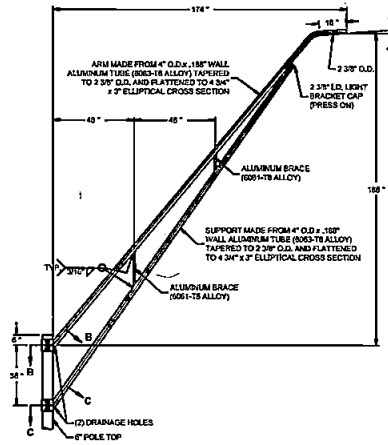

UTILITY CONFLICT POLE ARM

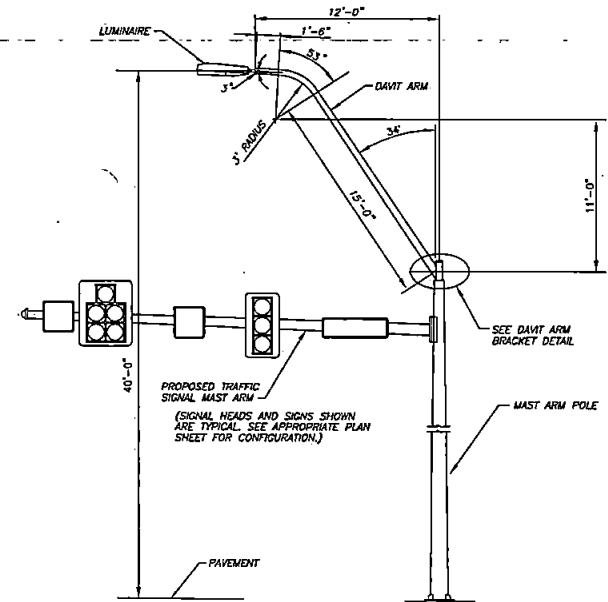

LUMINAIRE DAVIT ARM DETAIL
N.T.S.

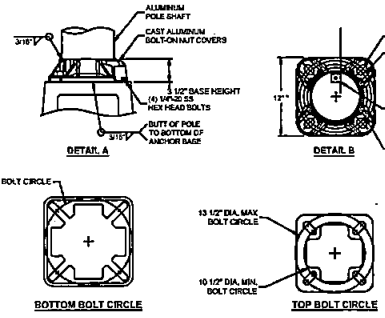

UTILITY CONFLICT POLE DETAILS

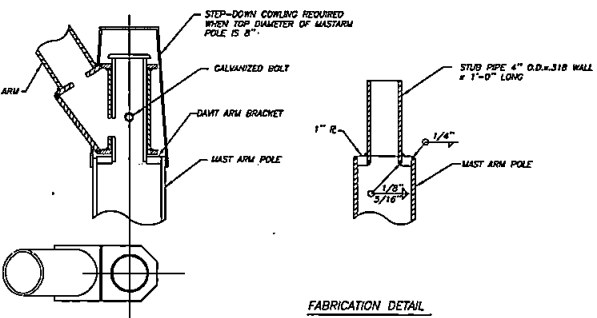
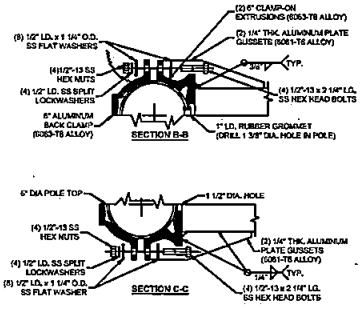

DAVIT ARM BRACKET DETAIL
N.T.S.

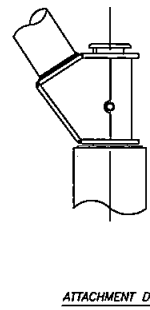

ATTACHMENT DETAIL

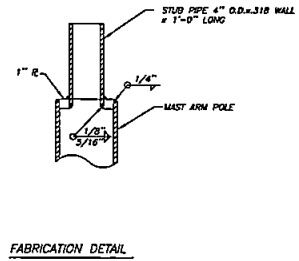

FABRICATION DETAIL

MAST ARM MOUNTED LUMINAIRE DETAILS

REVISIONS		DESCRIPTION		KIMLEY-HORN AND ASSOCIATES, INC. CERTIFICATE OF AUTHORIZATION NO. 695 JORDAN E. LEEP, P.E. P.E. LICENSE NO. 76102 1777 MAIN STREET, SUITE 200 SARASOTA, FLORIDA 34236	ST. JOHN'S COUNTY			LIGHTING SPECIAL DETAILS	SHEET NO. T-10
DATE	DESCRIPTION	DATE	DESCRIPTION		ROAD	COUNTY	PROJECT		
					US 1	ST. JOHN'S	LEWIS POINT RD/ ST. AUGUSTINE S DR		

THE OFFICIAL RECORD OF THIS SHEET IS THE ELECTRONIC FILE DIGITALLY SIGNED AND SEALED UNDER RULE 61G15-23.004, F.A.C.

SPECIAL MAST ARM ASSEMBLIES DATA TABLE																								
NUMBER OF LOCATIONS	STRUCTURE NUMBER	FIRST ARM				FIRST ARM EXTENSION				SECOND ARM				SECOND ARM EXTENSION				POLE						
		FA(ft)	FB(in)	FC(in)	FD(in)	FE(ft)	FF(in)	FG(in)	FH(in)	SA(ft)	SB(in)	SC(in)	SD(in)	SE(ft)	SF(in)	SG(in)	SH(in)	UA(ft)	UB(ft)	UC(in)	UD(in)	UE(in)	UF(deg)	UG(ft)
1	1	-	-	-	-	-	-	-	-	-	-	-	-	-	-	-	-	25	21	-	-	-	-	-
1	2	-	-	-	-	-	-	-	-	-	-	-	-	-	-	-	-	25.5	22.5	-	-	-	-	-
1	3	-	-	-	-	-	-	-	-	-	-	-	-	-	-	-	-	25	21	-	-	-	-	-
1	4	-	-	-	-	-	-	-	-	-	-	-	-	-	-	-	-	25	22	-	-	-	-	-

SPECIAL MAST ARM ASSEMBLIES DATA TABLE (CONT.)																							
STRUCTURE NUMBER	FIRST ARM CONNECTION (in) First Arm Camber Angle = 2 Degrees											SECOND ARM CONNECTION (in) Second Arm Camber Angle = 2 Degrees											
	#Bolts	HT	FJ	FK	FL	FN	FO	FP	FR	FS	FT	#Bolts	HT	SJ	SK	SL	SN	SO	SP	SR	SS	ST	
1	-	-	-	-	-	-	-	-	-	-	-	-	-	-	-	-	-	-	-	-	-	-	-
2	-	-	-	-	-	-	-	-	-	-	-	-	-	-	-	-	-	-	-	-	-	-	-
3	-	-	-	-	-	-	-	-	-	-	-	-	-	-	-	-	-	-	-	-	-	-	-
4	-	-	-	-	-	-	-	-	-	-	-	-	-	-	-	-	-	-	-	-	-	-	-

SPECIAL MAST ARM ASSEMBLIES DATA TABLE (CONT.)																							
STRUCTURE NUMBER	POLE BASE CONNECTION (in)					SHAFT AND REINF.						LUMINAIRE AND LUMINAIRE CONNECTION											
	#Bolts	BA	BB	BC	BF	DA(ft)	DB(ft)	RA	RB	RC	RD(in)	LA(ft)	LB(ft)	LC(in)	LD(in)	LE	LF(ft)	LG(in)	LH(in)	LI(in)	LK(in)	LI(deg)	
1	-	-	-	-	-	-	-	-	-	-	-	39.5	*	-	-	-	-	-	-	-	-	-	-
2	-	-	-	-	-	-	-	-	-	-	-	40	*	-	-	-	-	-	-	-	-	-	-
3	-	-	-	-	-	-	-	-	-	-	-	39.5	*	-	-	-	-	-	-	-	-	-	-
4	-	-	-	-	-	-	-	-	-	-	-	39.5	*	-	-	-	-	-	-	-	-	-	-

NOTES:
 1. WORK WITH INDEX 649-031.
 2. DESIGN WIND SPEED = 150 MPH

FOUNDATION NOTES:
 1. SEE SHEET T-12

*REFER TO LIGHTING SPECIAL DETAILS FOR DAVIT LUMINAIRE ATTACHMENT DETAILS

DATE		DESCRIPTION		DATE		DESCRIPTION		KIMLEY-HORN AND ASSOCIATES, INC. CERTIFICATE OF AUTHORIZATION NO. 695 JOSEPH A. ROBERTS JR., P.E. P.E. LICENSE NO. 78547 189 SOUTH ORANGE AVENUE, SUITE 1000 ORLANDO, FLORIDA 32801	ST. JOHNS COUNTY			SPECIAL MAST ARM ASSEMBLIES DATA TABLES		SHEET NO. T-13
ROAD		COUNTY		PROJECT		US 1	ST. JOHNS		LEWIS POINT RD/ ST. AUGUSTINE 5 DR					

THE OFFICIAL RECORD OF THIS SHEET IS THE ELECTRONIC FILE DIGITALLY SIGNED AND SEALED UNDER RULE 61G15-23.004, F.A.C.

POLE 2 - STATION 738+02.77 OFFSET 64.59' LT

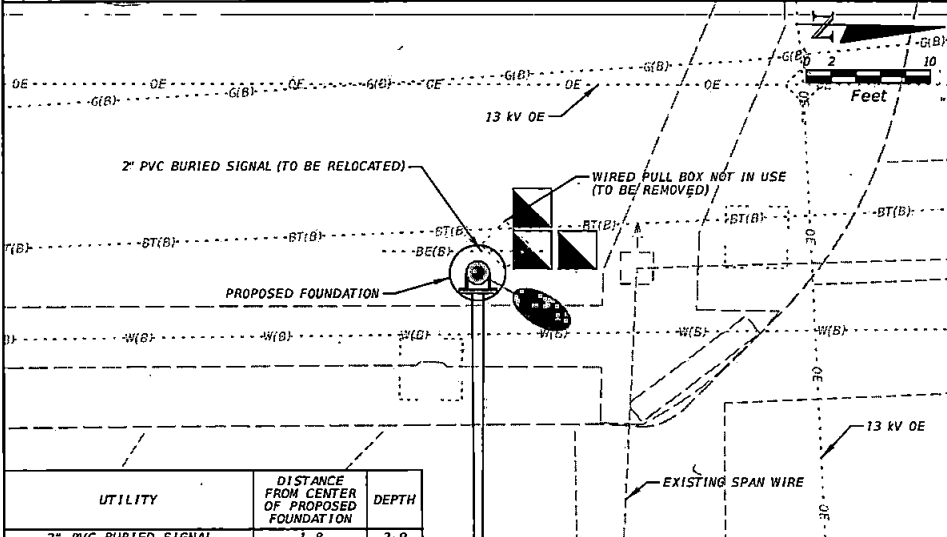

UTILITY	DISTANCE FROM CENTER OF PROPOSED FOUNDATION	DEPTH
2" PVC BURIED SIGNAL	1.8	2.9

POLE 3 - STATION 739+45.20 OFFSET 69.60' LT

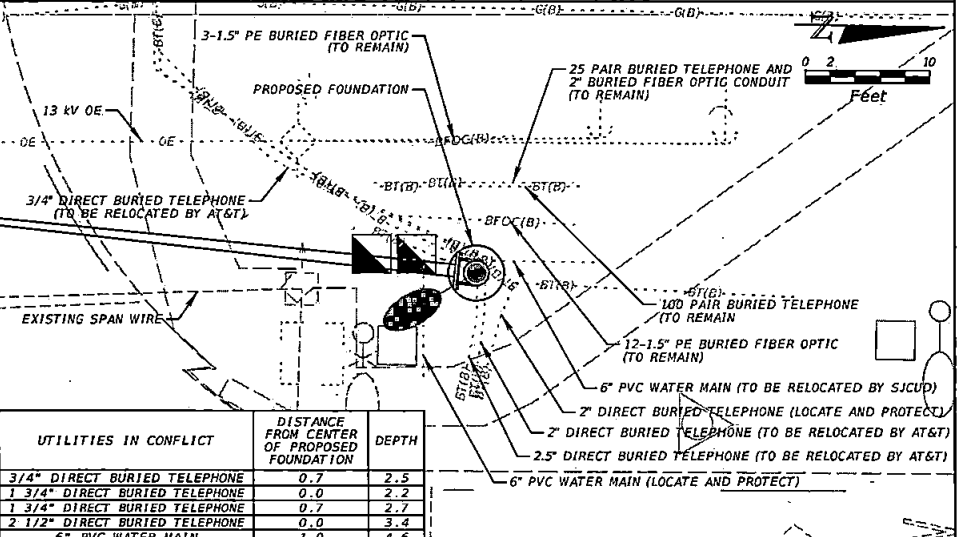

UTILITIES IN CONFLICT	DISTANCE FROM CENTER OF PROPOSED FOUNDATION	DEPTH
3/4" DIRECT BURIED TELEPHONE	0.7	2.5
1 3/4" DIRECT BURIED TELEPHONE	0.0	2.2
1 3/4" DIRECT BURIED TELEPHONE	0.7	2.7
2 1/2" DIRECT BURIED TELEPHONE	0.0	3.4
6" PVC WATER MAIN	1.0	4.6

POLE 1 - STATION 737+98.12 OFFSET 72.37' RT

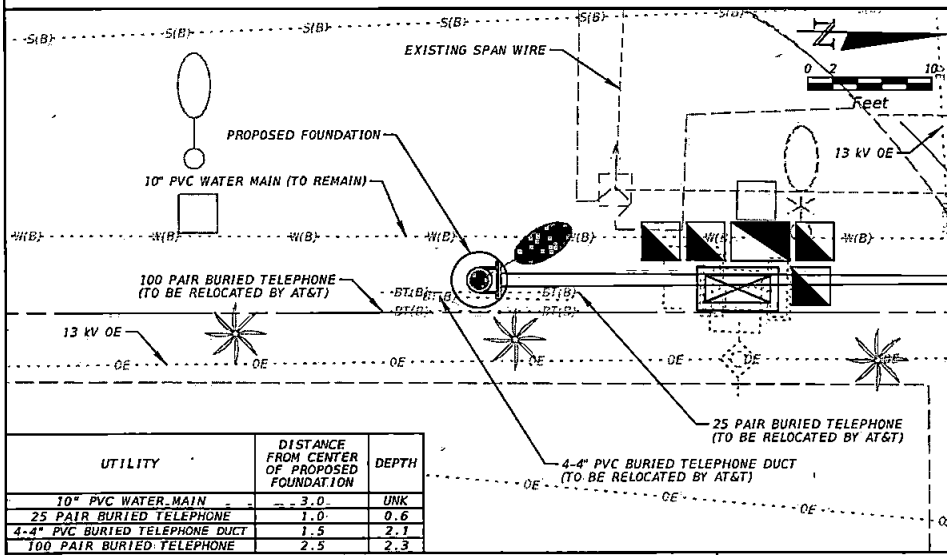

UTILITY	DISTANCE FROM CENTER OF PROPOSED FOUNDATION	DEPTH
10" PVC WATER MAIN	3.0	UNK
25 PAIR BURIED TELEPHONE	1.0	0.6
4-4" PVC BURIED TELEPHONE DUCT	1.5	2.1
100 PAIR BURIED TELEPHONE	2.5	2.3

POLE 4 - STATION 739+38.04 OFFSET 72.47' RT

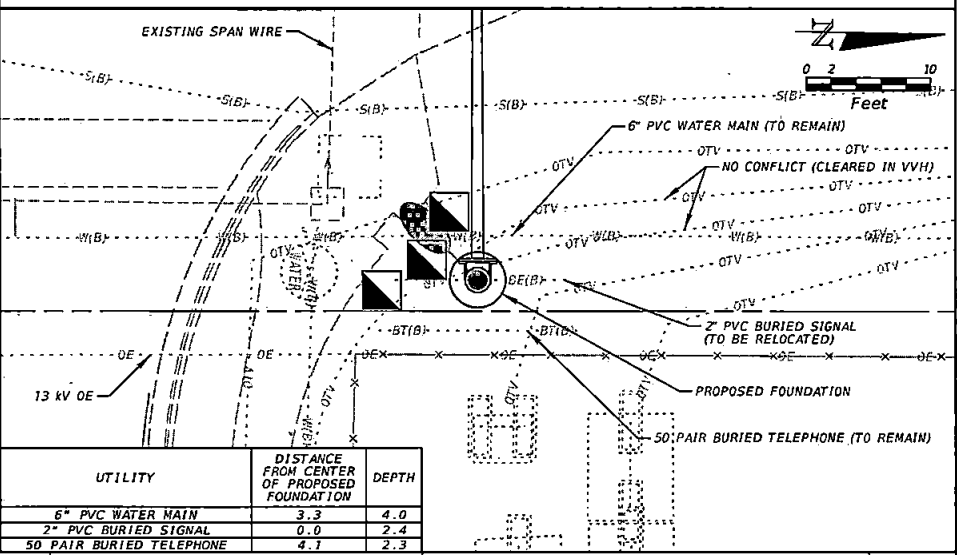

UTILITY	DISTANCE FROM CENTER OF PROPOSED FOUNDATION	DEPTH
6" PVC WATER MAIN	3.3	4.0
2" PVC BURIED SIGNAL	0.0	2.4
50 PAIR BURIED TELEPHONE	4.1	2.3

REVISIONS	
DATE	DESCRIPTION

KIMLEY-HORN AND ASSOCIATES, INC.
 CERTIFICATE OF AUTHORIZATION NO. 696
 MICHELLE B. MECCA, P.E.
 P.E. LICENSE NO. 53059
 12740 GRAN BAY PARKWAY WEST, SUITE 2350
 JACKSONVILLE, FLORIDA 32298

ST. JOHNS COUNTY		
ROAD	COUNTY	PROJECT
US 1	ST. JOHNS	LEWIS POINT RD/ ST. AUGUSTINE S DR

UTILITY LOCATION PLAN

SHEET NO.
T-14

THE OFFICIAL RECORD OF THIS SHEET IS THE ELECTRONIC FILE DIGITALLY SIGNED AND SEALED UNDER RULE 61G15-23.004, F.A.C.

SIGN NAME		Lewis Pt	QTY	SIGN NUMBER		STATION(S)
PANEL		BORDER		none		
WIDTH	9'-0"	WIDTH	0.5"			
HEIGHT	2'-0"	RADII	1.5"			
LEGEND	White	COLOR	White			
COLOR	Green					
SYMBOL(S)		ANGLE	X	Y	WID	HT
AR_Type	D	90	34.0	2	8	9
SIGN NUMBER		CLEARANCE	COLUMN SIZE	AVERAGE LENGTH		
		Top of Sign				

NO. OF LIGHT FIXTURES	FIXTURE SPACING	PHOTOMETRIC CURVE	WATT	VOLTAGE
-----------------------	-----------------	-------------------	------	---------

SIGN NAME		Lewis Pt	QTY	SIGN NUMBER		STATION(S)
PANEL		BORDER		none		
WIDTH	9'-0"	WIDTH	0.5"			
HEIGHT	2'-0"	RADII	1.5"			
LEGEND	White	COLOR	White			
COLOR	Green					
SYMBOL(S)		ANGLE	X	Y	WID	HT
AR_Type	D	270	64.4	2	8	9
SIGN NUMBER		CLEARANCE	COLUMN SIZE	AVERAGE LENGTH		
		Top of Sign				

NO. OF LIGHT FIXTURES	FIXTURE SPACING	PHOTOMETRIC CURVE	WATT	VOLTAGE
-----------------------	-----------------	-------------------	------	---------

COPY	L	o	w	i	s	P	o	i	n	t	L		
SPACE	7.0	8.7	8.6	13.1	4.9	6.6	10	9.6	9.9	9.6	5.2	7.9	92.2
COPY	R	o	A	D	L								
SPACE	49.6	5.9	5.9	7.1	4.9	34.5	23.8						
COPY													
SPACE													
COPY													
SPACE													
COPY													
SPACE													
COPY													
SPACE													

COPY	L	o	w	i	s	P	o	i	n	t	L		
SPACE	7.9	8.7	8.6	13.1	4.9	6.6	10	9.6	9.9	9.6	5.2	7.9	92.2
COPY	R	o	A	D	L								
SPACE	34.6	5.9	5.9	7.1	4.9	49.6	23.8						
COPY													
SPACE													
COPY													
SPACE													
COPY													
SPACE													
COPY													
SPACE													

SIGN NAME		St. Aug S	QTY	SIGN NUMBER		STATION(S)
PANEL		BORDER		none		
WIDTH	9'-0"	WIDTH	0.5"			
HEIGHT	2'-0"	RADII	1.5"			
LEGEND	White	COLOR	White			
COLOR	Green					
SYMBOL(S)		ANGLE	X	Y	WID	HT
AR_Type	D	270	65.4	3	8	9
SIGN NUMBER		CLEARANCE	COLUMN SIZE	AVERAGE LENGTH		
		Top of Sign				

NO. OF LIGHT FIXTURES	FIXTURE SPACING	PHOTOMETRIC CURVE	WATT	VOLTAGE
-----------------------	-----------------	-------------------	------	---------

SIGN NAME		St. Aug S	QTY	SIGN NUMBER		STATION(S)
PANEL		BORDER		none		
WIDTH	9'-0"	WIDTH	0.5"			
HEIGHT	2'-0"	RADII	1.5"			
LEGEND	White	COLOR	White			
COLOR	Green					
SYMBOL(S)		ANGLE	X	Y	WID	HT
AR_Type	D	90	33.6	3	8	9
SIGN NUMBER		CLEARANCE	COLUMN SIZE	AVERAGE LENGTH		
		Top of Sign				

NO. OF LIGHT FIXTURES	FIXTURE SPACING	PHOTOMETRIC CURVE	WATT	VOLTAGE
-----------------------	-----------------	-------------------	------	---------

COPY	S	t	.	A	u	g	u	s	t	i	n	e	S	L				
SPACE	4.5	8.2	5.4	1.6	6	10	7.8	8.5	7.6	7	6.7	4.8	7.8	5.3	6	6.5	4.5	99
COPY	D	R	I	V	E	L												
SPACE	33.6	6.3	6.1	2.3	6.6	4.4	48.6	25.7										
COPY																		
SPACE																		
COPY																		
SPACE																		
COPY																		
SPACE																		

COPY	S	t	.	A	u	g	u	s	t	i	n	e	S	L				
SPACE	4.5	8.2	5.4	1.6	6	10	7.8	8.5	7.6	7	6.7	4.8	7.8	5.3	6	6.5	4.5	99
COPY	D	R	I	V	E	L												
SPACE	48.6	6.3	6.1	2.3	6.6	4.4	33.6	25.7										
COPY																		
SPACE																		
COPY																		
SPACE																		
COPY																		
SPACE																		

DATE		DESCRIPTION		REVISIONS		DATE		DESCRIPTION		KIMLEY-HORN AND ASSOCIATES, INC. CERTIFICATE OF AUTHORIZATION NO. 696 NICHELLE B. MECCA, P.E. P.E. LICENSE NO. 55059 12740 GRAN BAY PARKWAY WEST, SUITE 2350 JACKSONVILLE, FLORIDA 32228			ST. JOHNS COUNTY ROAD COUNTY PROJECT US 1 ST. JOHNS LEWIS POINT RD/ ST. AUGUSTINE S DR			SHEET NO. T-15	
------	--	-------------	--	-----------	--	------	--	-------------	--	---	--	--	---	--	--	-------------------	--

THE OFFICIAL RECORD OF THIS SHEET IS THE ELECTRONIC FILE DIGITALLY SIGNED AND SEALED UNDER RULE 61G15-23.004, F.A.C.

LOCATION PLAN



APPROXIMATE LOCATION OF STANDARD PENETRATION TEST BORING

NOTE: PLAN AS SHOWN IS PRELIMINARY FOR REPRESENTATION OF BORING LOCATION ONLY AND MAY NOT BE INDICATIVE OF FINAL CONTRACT PLANS.

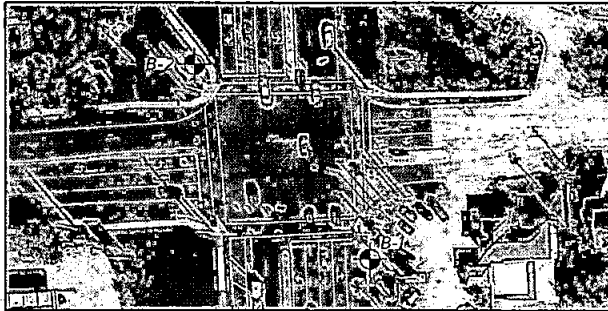

LEGEND

- SAND SAND WITH SILT
- LIMEROCK
- TOPSOIL

- (SP) UNIFIED SOIL CLASSIFICATION SYSTEM SYMBOL
- ENCOUNTERED GROUNDWATER LEVEL MEASURED AT TIME OF DRILLING
- $w=27$
 $-200=1$ NATURAL MOISTURE CONTENT (%)
FINES PASSING No. 200 SIEVE (%)
- N STANDARD PENETRATION RESISTANCE IN BLOWS PER FOOT
- N# EQUIVALENT STANDARD PENETRATION RESISTANCE VALUE CONVERTED FROM STATIC HAND CONE PENETROMETER READINGS
- BT BORING TERMINATION DEPTH
- HA BORING ADVANCED WITH HAND-HELD BUCKET AUGER DUE TO POSSIBLE UNDERGROUND UTILITIES.
- 50/5.5" INDICATES 50 HAMMER BLOWS DROVE SPLIT SPOON SAMPLER 5.5 INCHES.

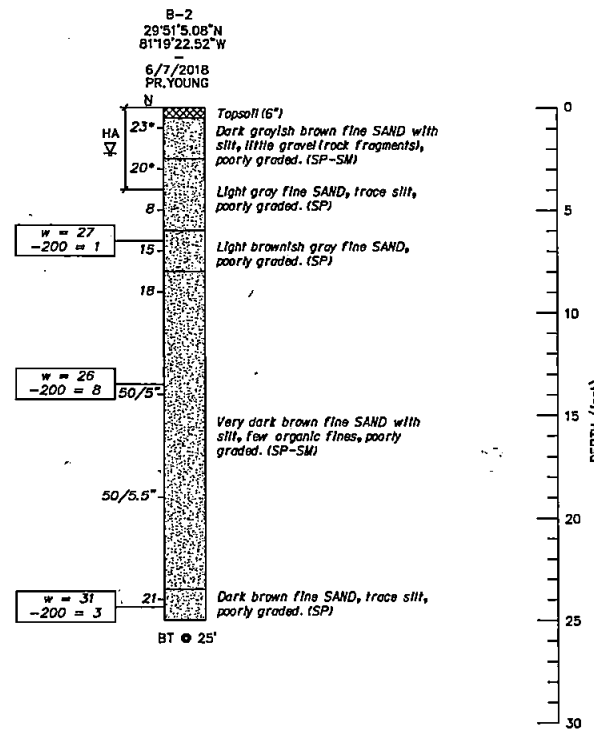
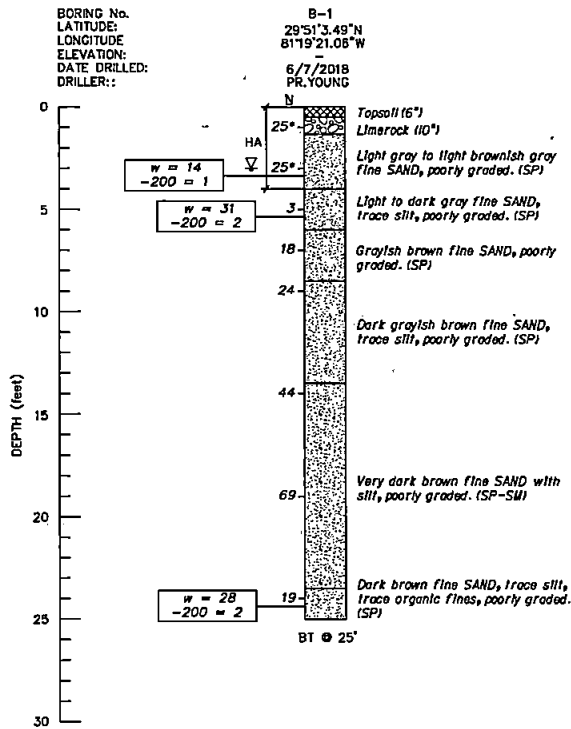

STANDARD PENETRATION TEST DATA

SPOON INSIDE DIA.	1 3/8 IN.
SPOON OUTSIDE DIA.	2 IN.
AVG. HAMMER DROP	30 IN.
HAMMER WEIGHT	140 LBS.

GRANULAR MATERIALS

RELATIVE DENSITY	SPT (BLOWS/FT.)
VERY LOOSE	LESS THAN 3
LOOSE	3-8
MEDIUM DENSE	8-24
DENSE	24-40
VERY DENSE	GREATER THAN 40

SILTS AND CLAYS

CONSISTENCY	SPT (BLOWS/FT.)
VERY SOFT	LESS THAN 1
SOFT	1-3
FIRM	3-6
STIFF	6-12
VERY STIFF	12-24
HARD	GREATER THAN 24

ENVIRONMENTAL CLASSIFICATION:

SUBSTRUCTURE: CONCRETE: SLIGHTLY AGGRESSIVE
 STEEL: SLIGHTLY AGGRESSIVE
 RIG TYPE: CME 45B
 HAMMER TYPE: AUTOMATIC HAMMER

NOTES:

- 1) LAYER BOUNDARIES ARE APPROXIMATE AND REPRESENT SOIL LAYERS AT EACH TEST HOLE LOCATION ONLY. SUBSURFACE VARIATIONS BETWEEN BORINGS SHOULD BE ANTICIPATED.
- 2) LATITUDE AND LONGITUDE WERE OBTAINED USING HAND-HELD GPS DEVICE (GARMIN GPSMAP 78I) AT THE TIME OF DRILLING AND ARE CONSIDERED APPROXIMATE.

REVISIONS				BRETT H. HARBISON, P.E. FLORIDA PE NO. 74679 MESKEL & ASSOCIATES ENGINEERING, LLC 8936 WESTERN WAY, SUITE 12 JACKSONVILLE, FLORIDA 32256 CERTIFICATE OF AUTHORIZATION NO. 28142	ST. JOHNS COUNTY			REPORT OF CORE BORINGS MAST ARM STRUCTURES	SHEET NO. T-17
DATE	DESCRIPTION	DATE	DESCRIPTION		ROAD	COUNTY	PROJECT		
					US 1	ST. JOHNS	LEWIS POINT RD/ ST. AUGUSTINE S DR		

THE OFFICIAL RECORD OF THIS SHEET IS THE ELECTRONIC FILE DIGITALLY SIGNED AND SEALED UNDER RULE 61G15-23.004, F.A.C.